

Technical Specifications

55544

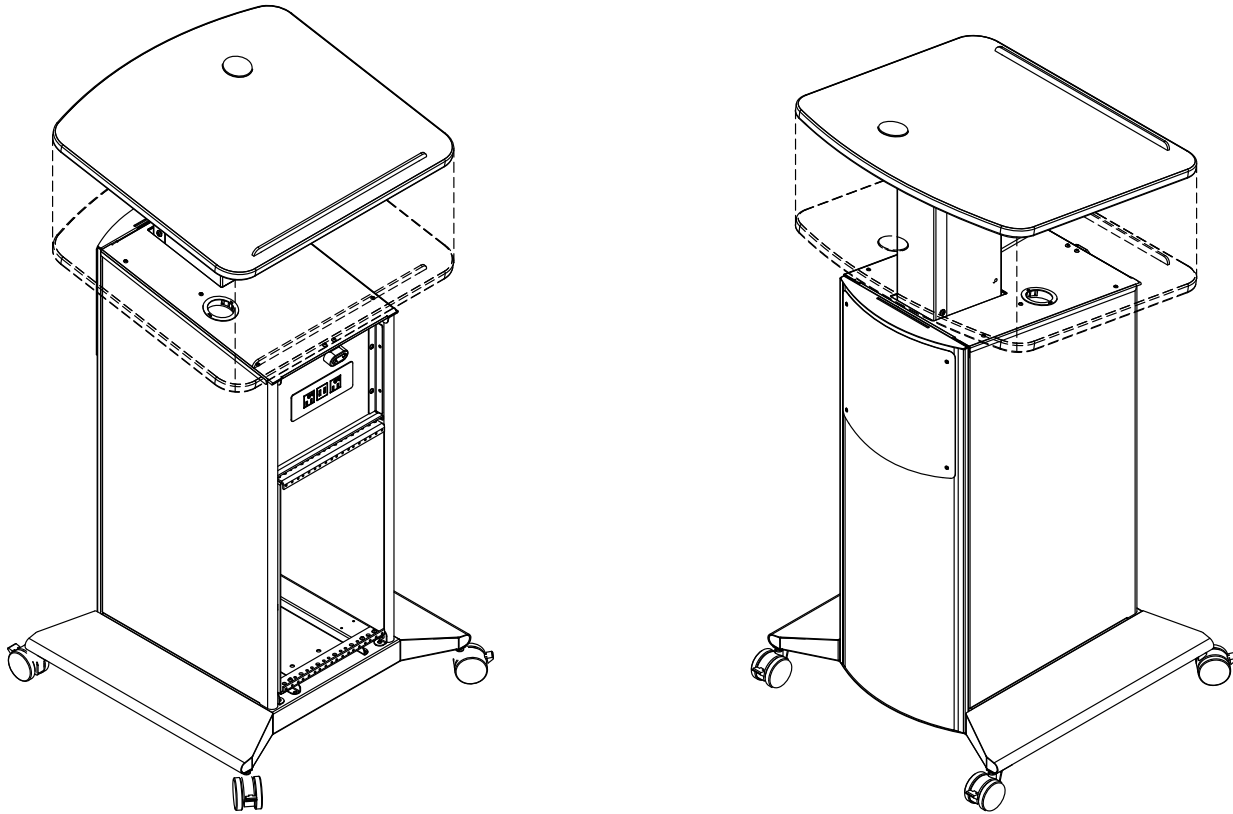

The Adjustable Height SLIM Lectern is Spectrum's solution to the minimalist (small footprint, thin and sleek) lectern movement. This lectern is electrically height-adjustable, fully-supports AV equipment and provides a surprising amount of storage capacity for its size. Available with glides for stationary use, or casters for mobile use, the lectern can be configured to your specific environment using options like a 6RU rack cube for AV equipment, an underbridge for power modules or other surface-mount devices, and a logo panel.

Features and Benefits

- 10" of electric height adjustment provides comfort for different user heights
- Durable powder coated steel chassis provides a long-lasting finish
- Angled, scratch and impact-resistant, high-pressure laminate top provides durability, ergonomics, and styling
- Side panels are available in matching metal or laminate
- 3" twin-wheel casters provide easy mobility (all 4 locking)
- Glides available if mobility is not necessary or desired
- Removable audience-side panel provides easy-access to equipment
- Cable grommets keep wires and cords organized
- Internal shelf provides storage (one included standard)
- Optional removable rack cube (6RU) simplifies installation for any equipment configuration, provides mounting capabilities for multiple cooling fans, and provides the ability to integrate equipment remotely before being installed into the lectern at a later date.
- Optional customizable logo panel simplifies adding or changing logos
- Optional power module provides ability to charge laptops or phones
- Optional internal shelf provides additional storage
- Lectern ships fully-assembled for quick, simple integration and deployment
- Warranted to be free of all defects in materials and workmanship for 10 years
- Designed and assembled in Chippewa Falls, WI, USA

Color Options

Available in Spectrum Expressions colors.
See spectrumfurniture.com for complete color information.

Ordering Instructions

Spectrum has designed this product to receive the useful options shown here.
To ensure your options are ordered correctly please call 1-800-235-1262.

Construction

- The worksurface and “wood” side panels are constructed from 3/4” thick composite board with .030” high-pressure laminate on one face, and a balancing phenolic backer on the opposing face.
- Metal components consist of 16 and 20-gauge steel
- Worksurface edges are covered with 3mm vinyl
- All metal components are finished with a scratch-resistant powder coat epoxy
- Each Slim Adjustable Lectern is factory-assembled, and shipped on its own skid. Customer assembles casters / glides.

Specifications

Upper internal area (nominal)	11.125"W [28.3 cm] x 9.06"D [23 cm] x 7.894"H [20 cm]	
Lower internal area (nominal)	11.125"W [28.3 cm] x 14.677"D [37.3 cm] x 19.477"H [49.47 cm]	
Steel Shelf	Vertical adjustability: 2" spaced holes in side panels	
3" Twin Wheel Casters	Weight capacity 90 lb [40.9 kg] each	
Electrical	<ul style="list-style-type: none"> • Range of motion: 10" [25.4 cm] • ~10 seconds from fully-lowered to fully-raised • Inverter: 120V @ 60Hz, max output 300 watts • Motor: 18V / 10 amps • Typical electrical load during operation: 4.3 amps @ 120 VAC • Anti-collision protection 	<ul style="list-style-type: none"> • 11' [335 cm] nominal 3-wire power cord • Max load: 800N (180 lb) [82 kg] • Actuator features non-hydraulic, permanently lubricated screw jacks • Actuator rated for 20,000 cycles • Approved according to EN 60335-1 and UL 962
Certifications / Compliance	Meets or exceeds applicable ANSI-BIFMA test standards	
Unit weight (nominal)	58 lb [40.4 kg] (lectern w/ steel side panels) 74 lb [33.6 kg] (lectern w/ laminate side panels)	
Shipping weight (nominal)	83 lb [37.7 kg] (lectern w/ steel side panels) 99 lb [45 kg] (lectern w/ laminate side panels)	

Specifications subject to change without notice

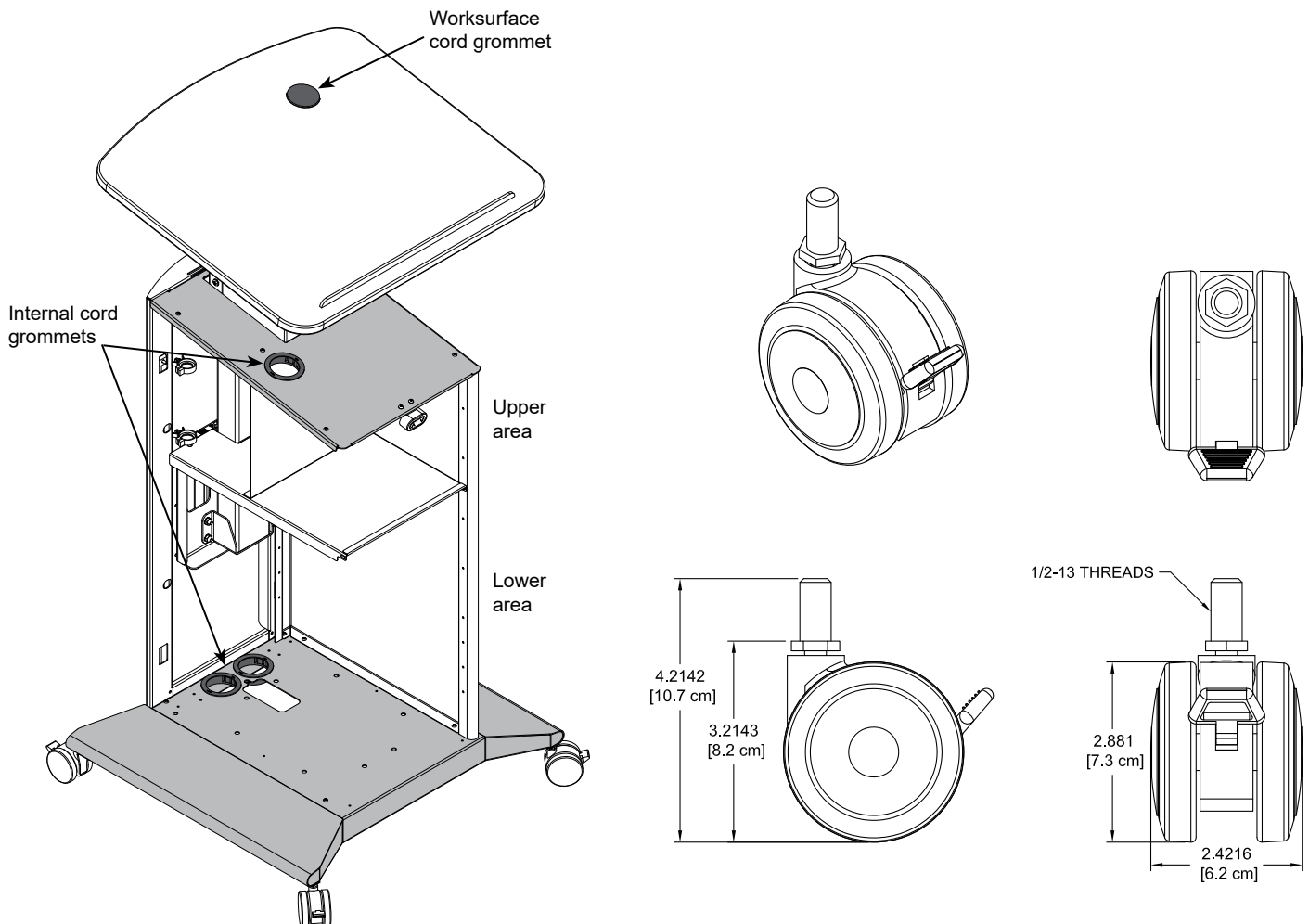

Side Panel Style

- ORDER CODE 1 = Matching Metal
- ORDER CODE 2 = Matching Laminate

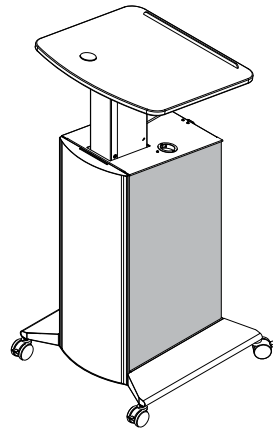

Mobility Options

ORDER CODE 01 = 3" Twin-wheel Casters

ORDER CODE 02 = Glides

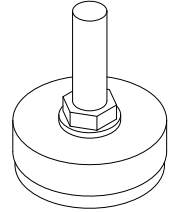
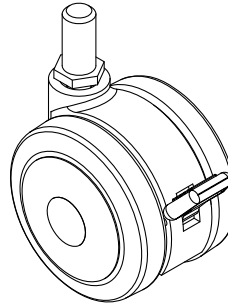

Underbridge Options

ORDER CODE 0 = None

ORDER CODE 1 = Underbridge-Blank

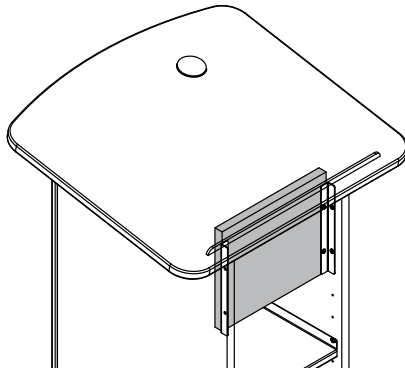

- ORDER CODE 2 = Underbridge w/ Power Module - Black
- ORDER CODE 3 = Underbridge w/ Power Module - Silver
- ORDER CODE 4 = Underbridge w/ Power Module - White

- (2) AC receptacles (tamper-resistant)
- (2) USB ports rated at 2.1A each (10.5 watts)
- Aluminum housing and flange
- 10' 14AWG *3C power cord
- When specified, the Power Module is mounted in an "underbridge" panel (10.875"W x 9"H) below the worksurface
- Panel cutout size: 5.65"W x 1.65"D
- ETL-certified

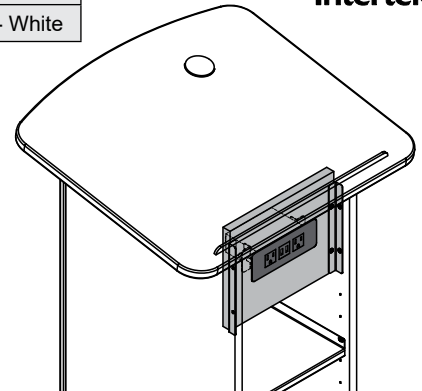

Rack Cube

- ORDER CODE 0 = None
- ORDER CODE 1 = 6RU Vertical Rack Cube

- 6RU of rack space
- Provides the ability to integrate equipment remotely before installation into the lectern
- Polyethylene slides on bottom for easy removal / installation
- Rack equipment mounts vertically
- Color: black

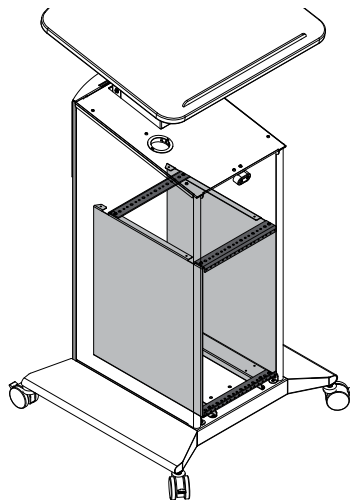

Note: When configured, the rack cube will be secured to the lectern base with screws for shipping purposes.

Customized Logo Panel

- ORDER CODE 0 = None
- ORDER CODE 1 = Yes-with matching laminate backer
- ORDER CODE 3 = Yes-with black laminate backer
- ORDER CODE 4 = Yes-with white laminate backer
- ORDER CODE 5 = Yes-with printed backer

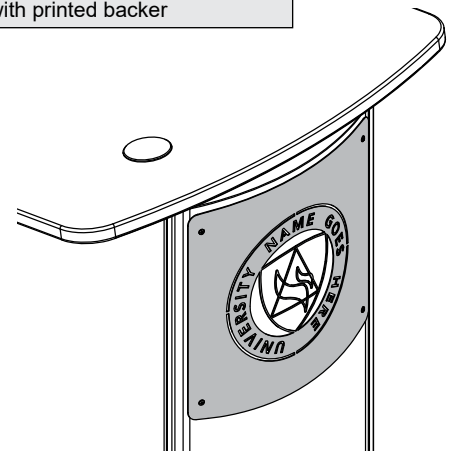

Adjustable Height Slim Lectern
w/ 3" Twin wheel casters
(shown with optional accessories)

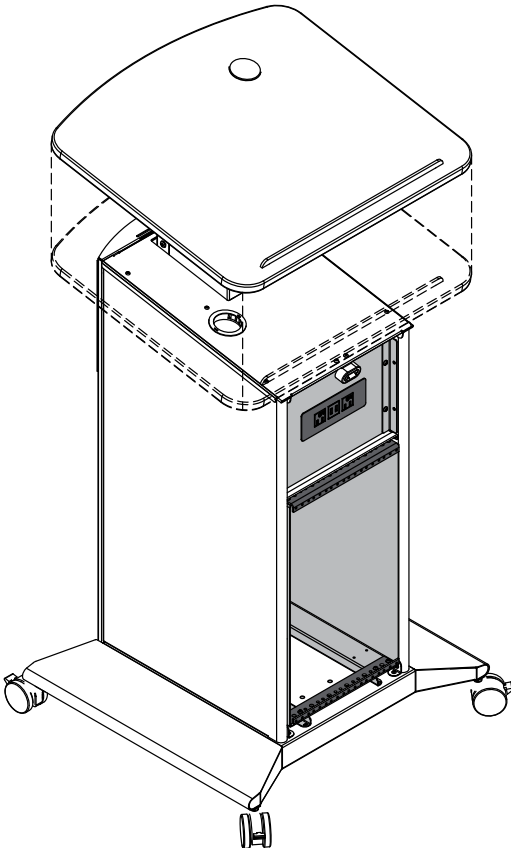

Removable audience-side panel

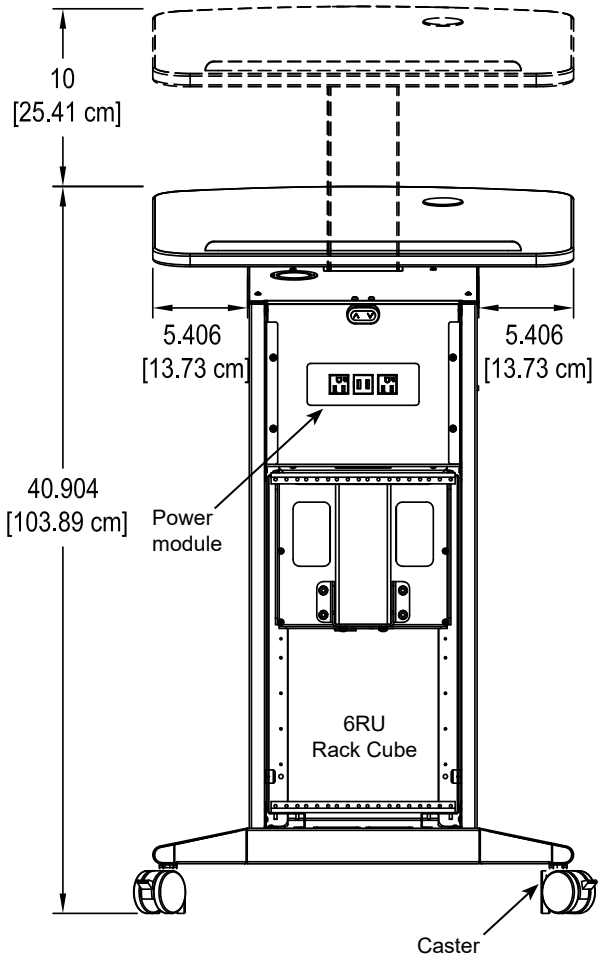
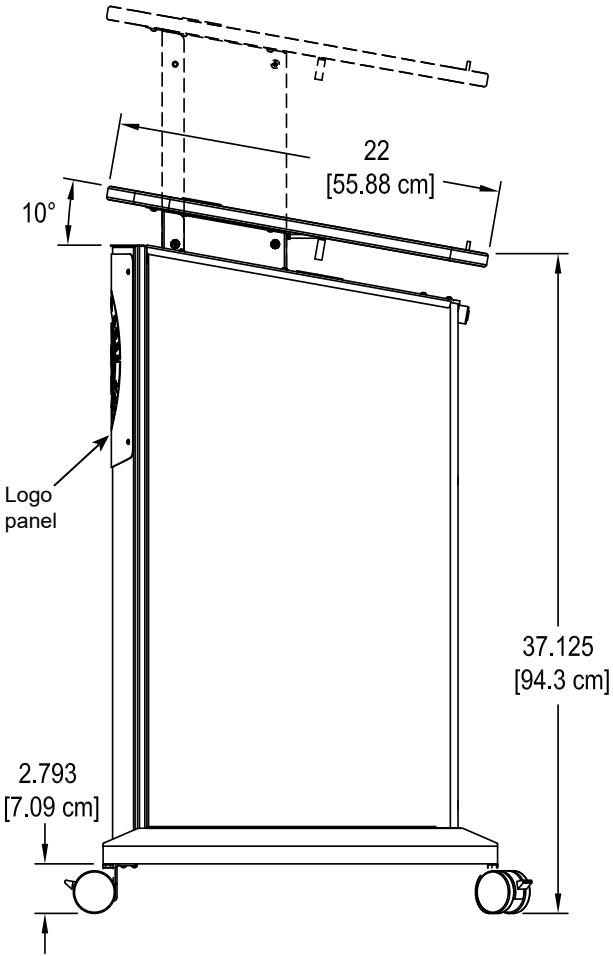
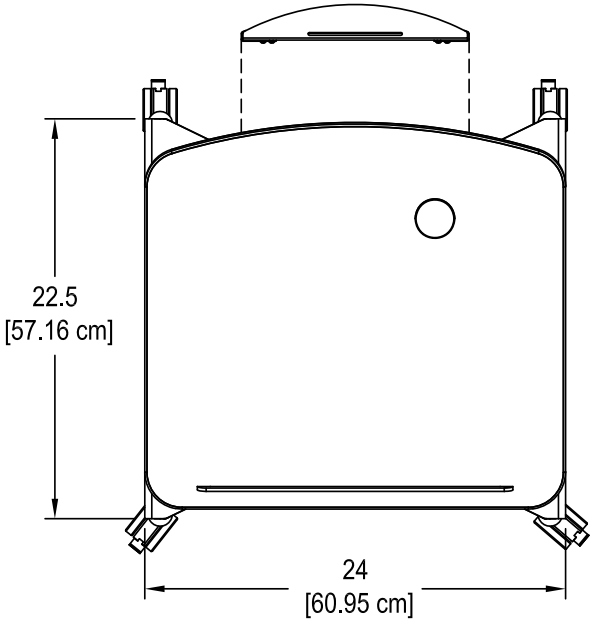

Adjustable Height Slim Lectern
w/ glides

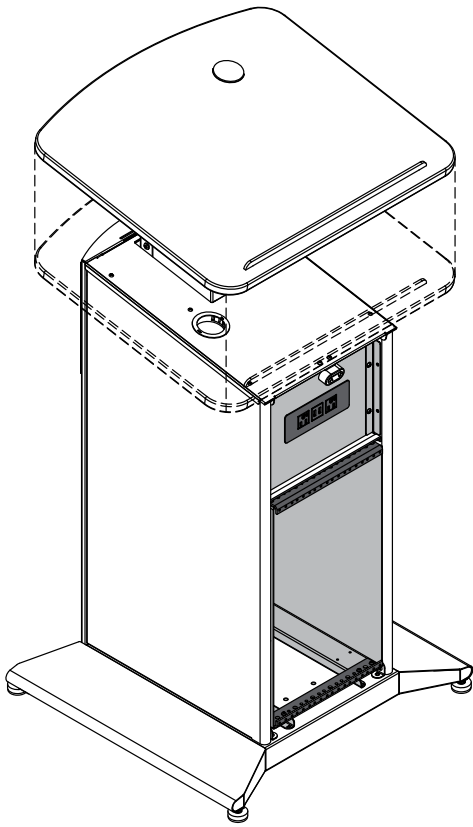

Removable
audience-side panel

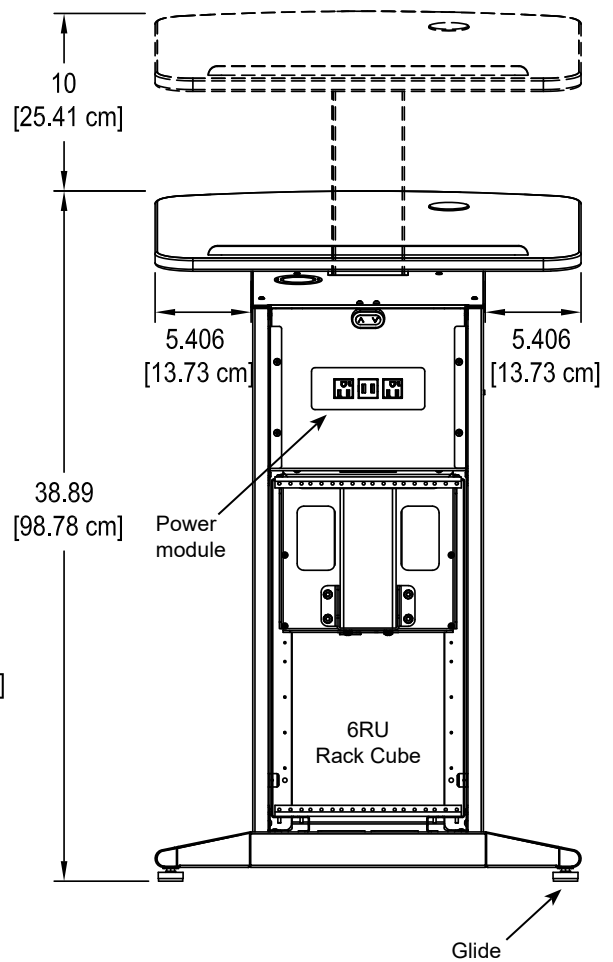
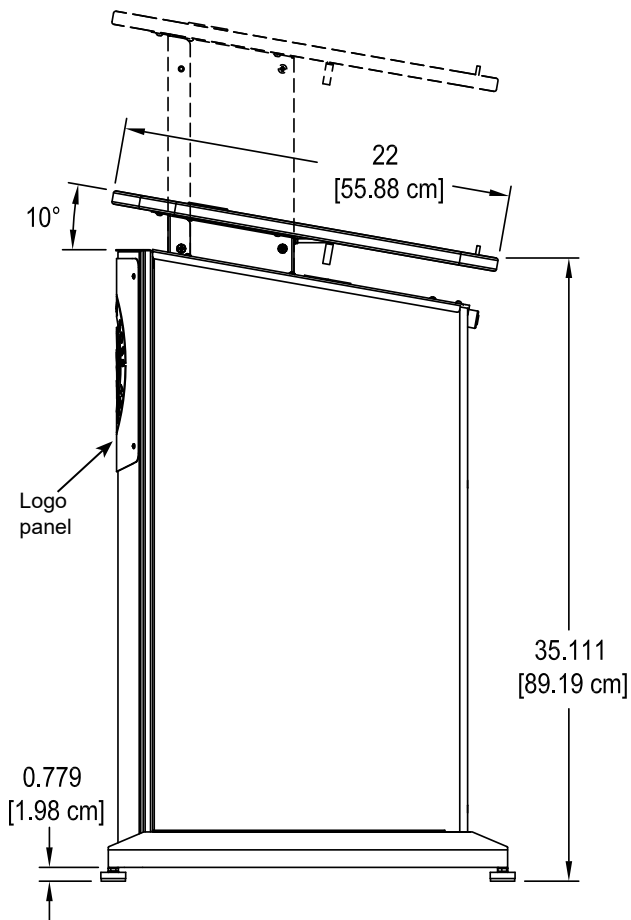
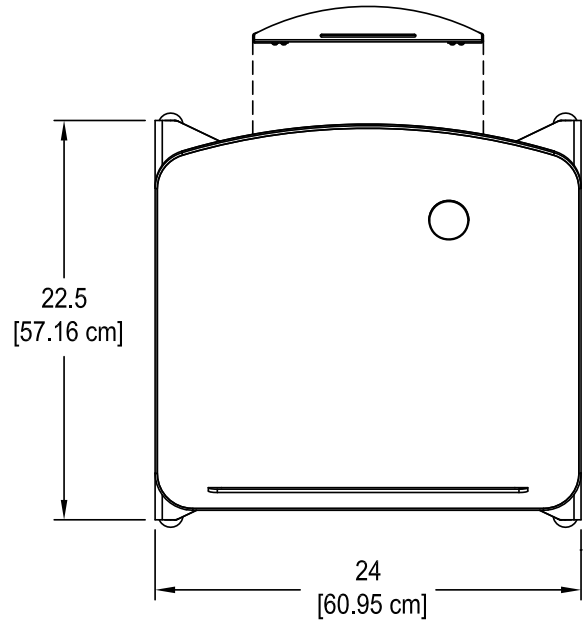

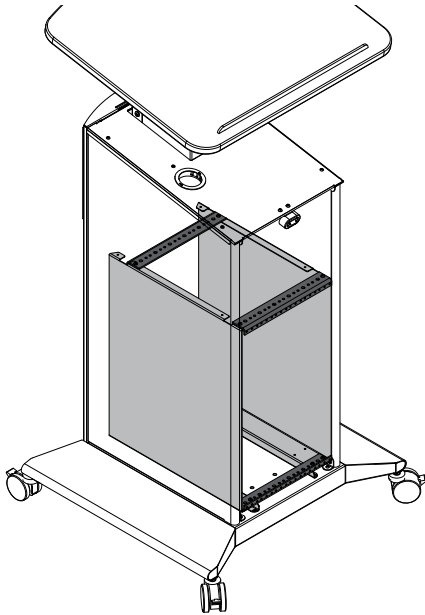

6RU Vertical Rack Cube - 97524

- Provides the ability to integrate equipment remotely before installation into the lectern
- Rack equipment mounts vertically
- Color: black

Rack rail:	6RU front and rear
Rack cube dimensions:	10.75"W [27.3 cm] x 17.078"D [43.38 cm] x 20"H [50.8 cm]
Available equipment depth:	14"D [35.56 cm]
Unit weight:	19 lb [18.63 kg]
Shipping weight:	20 lb [9.08 kg]

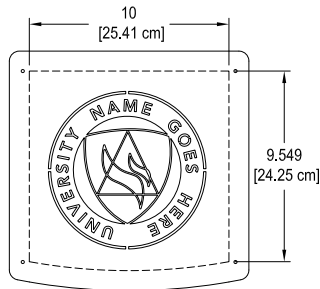
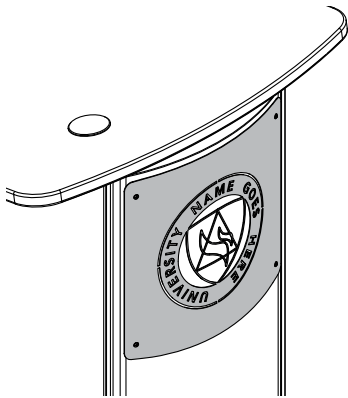
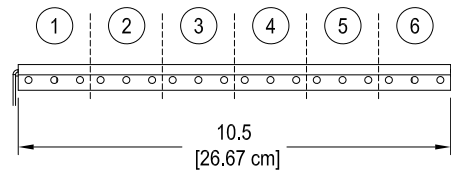

Customized Logo Panel - 55513

- Attaches to audience-side panel
- Available with black, white, or matching laminate backer
- To get panel customized-contact Spectrum for details
- New logos require a first time logo charge
- 20ga steel
- Customer-installed

Panel dimensions:	12"W [30 cm] x 12"H [30 cm] x .06"D [1.5 mm]
Available logo area:	10"W [25.41 cm] x 9.549"H [24.25]
Unit weight:	1.5 lb [.681 kg]
Shipping weight:	2.5 lb [1.14 kg]

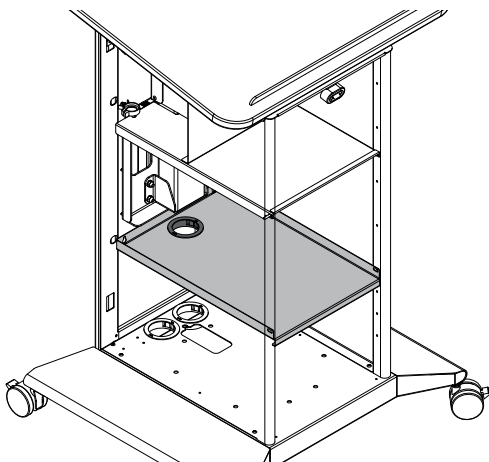

Shelf - 55514

- Provides additional storage in lower area
- Includes 2" grommet for cord management
- Vertical adjustability: 2" spaced holes in side panels
- Not compatible with rack cube
- 20ga steel
- Customer-installed

Dimensions:	11.1"W [28.2 cm] x 16.6"D [42.2 cm] x 1.5"H [3.8 cm]
Unit weight:	2.5 lb [1.14 kg]
Shipping weight:	3.5 lb [1.59 kg]

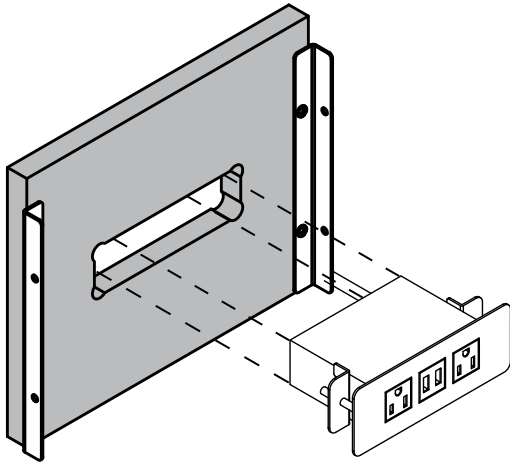

Underbridge with Power Module - 96516

- (2) AC receptacles (tamper-resistant)
- (2) USB ports rated at 2.1A each (10.5 watts)
- Aluminum housing and flange
- 10' 14AWG *3C power cord
- Power module is ETL-certified
- Scratch, impact, fingerprint-resistant, high-pressure textured black laminate face
- Includes mounting brackets and hardware
- Customer installed



Panel dims:	10.875"W [27.6 cm] x .75"D [1.9 cm] x 9"H [22.86 cm]
Cutout:	5.65"W [14.35 cm] x 1.65"D [4.19 cm]
Power cord:	10' [305 cm] 14AWG *3C power cord
Power receptacles:	125V, 60hz, 15A tamper-resistant
USB charging ports:	2.1A (10.5W) (not data-compatible)
Module Dims:	6.38"W [16.2 cm] x 2.36"D [6 cm] x 3.54"H [9 cm]
Unit weight:	4.5 lb [2 kg]
Shipping weight:	5.5 lb [2.5 kg]

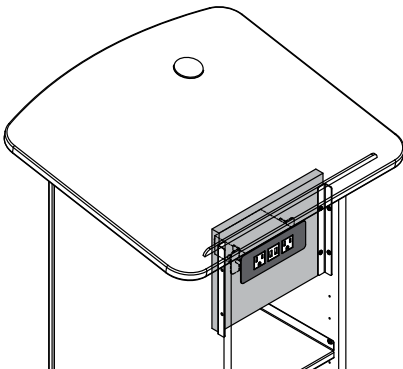

Product update
New USB-C Power Module version available. See details at:
www.spectrumfurniture.com

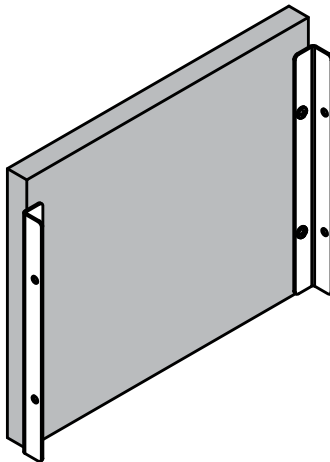

Underbridge-Blank - 96515

- Blank panel simplifies adaptation to technology changes or upgrades
- Scratch, impact, fingerprint-resistant, high-pressure textured black laminate face
- Includes mounting brackets and hardware
- Customer installed

Panel dims:	10.875"W [27.6 cm] x .75"D [1.9 cm] x 9"H [22.86 cm]
Max cutout area:	9.75"W [24.77 cm] x 7"H [17.78 cm]
Unit weight:	2.5 lb [1.1 kg]
Shipping weight:	3.5 lb [1.59 kg]

If a custom cutout is needed, contact Spectrum to specify cutout size.

Cutouts can be made in the blank insert panel by the customer after the lectern has been purchased, but are only recommended within the maximum cutout area listed.

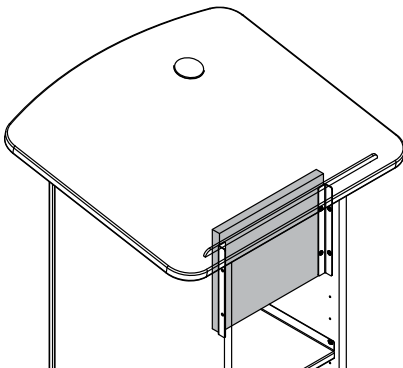

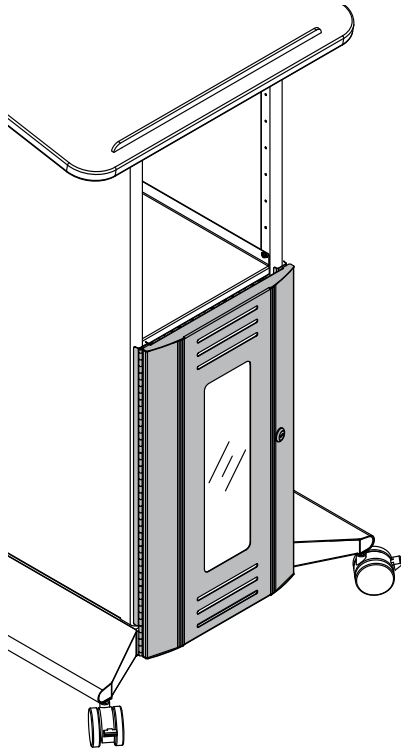

Locking Door - 55538

- Single-point lock
- Clear acrylic panel
- Vents provide cooling for equipment
- For instructor-side installation
- Can be installed to be hinged from the left or right side

Dimensions:	12.88"W [32.7 cm] x 2.75"D [7 cm] x 23.13"H [58.8 cm]
Unit weight:	6 lb [2.7 kg]
Shipping weight:	7 lb [3.2 kg]



Rechargeable Battery Pack System - 99045

- Creates a mobile lectern / desk by providing the ability to operate the unit in locations without AC power
- Compact, lightweight lithium-ion battery plugs into and charges from the existing lectern control box
- On-board LED light bars indicate charge capacity level
- Audio alarm signals when charging is needed
- Thermal switch protection, overcurrent protection
- Easy customer-installation

Battery Type	Lithium-ion
Capacity	2.2 Ah / 53 Wh
Voltage (nominal)	24V
Discharge current	9A (max)
Max charging voltage	40V DC
Charging current	0.5 A
Certifications	EN 62133 (Battery safety testing) UL 1642 (Lithium cells, standard test) UN 38.3 (Transportation of Lithium batteries) UL 2054 (Household and commercial batteries) EN 60335-1 with CBH Advanced
Unit weight: (nominal)	1.32 lb [.6 kg]
Shipping weight: (nominal)	2 lb [.9 kg]

Battery / Control Box Compatibility:

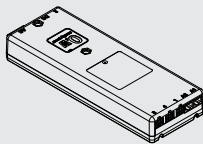

The CBD6S Linak control box is compatible with this battery pack.

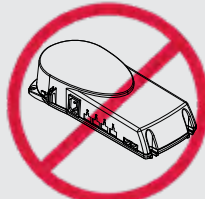

Older CBD4 Linak control boxes are not compatible with this battery pack.

Rack-mount Accessories

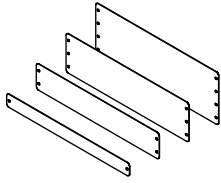

Rack-Mount Blanks

1RU - 97510 3RU - 97512
2RU - 97511 4RU - 97513

- Fills rack spaces where components are not needed
- 16 ga steel
- Shipping weight: <1 lb [45 kg]

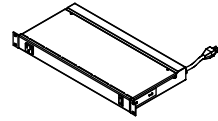

9-Outlet Power Strip - 1RU - 99021

- 8 outlets rear (breaker-protected)
- 1 convenience outlet front
- 115VAC, 60 Hz, 15 amps max
- 9' power cord
- Front LED power switch
- Enhanced surge protection
- ETL-listed, UL-listed
- 19"W [48.27 cm] x 9.25"D [23.5 cm] x 1.74"H [4.41 cm]
- Shipping weight: 8.7 lb [3.9 kg]

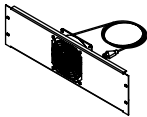

Single Fan - 3RU - 97507

- 50 cfm
- 120V~50/60 Hz, 15/13W
- RoHS
- 19"W [48.27 cm] x 1.56"D [3.97 cm] x 5.25"H [13.33 cm]
- Shipping weight: 3.78 lb [1.7 kg]

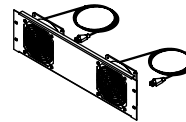

Double Fan - 3RU - 97506

- 100 cfm
- 120V~50/60 Hz, 15/13W
- RoHS
- 19"W [48.27 cm] x 1.56"D [3.97 cm] x 5.25"H [13.33 cm]
- Shipping weight: 5.47 lb [2.5 kg]

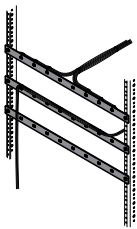

Wire Lace Kit - 95517

- Provides wire management
- Mounts to standard rack rails
- Includes (3) lace straps and mounting screws
- Includes (12) 5.5" zip ties
- Shipping weight: 1.25 lb [.57 kg]

See spectrumfurniture.com for the latest accessories and detailed warranty information.

Warranty

We will make it right for you!

Thanks for choosing Spectrum! Spectrum is committed to provide complete customer satisfaction. Each of our products is manufactured from the best materials available and each product is stringently monitored throughout the production process through our P.A.C.E. program (Product Assurance to meet Customer Expectations).

We expressly warrant that Spectrum products will be of good quality and workmanship and free from defect for the period set out in the warranty from the date of delivery.

For a listing of all product specific warranty terms please visit our website at:

<https://www.spectrumfurniture.com/en/resources/purchasing-terms-warranty>

1-800-235-1262

Toll-free HELPLINE

spectrum@spectrumfurniture.com