

# Assembly Instructions

## ⚠ Important ⚠

Before you begin, read and comply with all safety and operating instructions, and ensure all parts and correct quantities are included.

Any parts damaged during shipment must be reported within 5 days of receipt. To report information regarding missing parts or damage, to purchase parts or accessories, or if you have any questions, please contact us.

[www.spectrumfurniture.com](http://www.spectrumfurniture.com)  
800-235-1262, 715-723-6750

*Thank you for purchasing Spectrum products!*

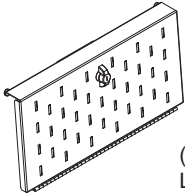

(1) 0176828  
Locking door

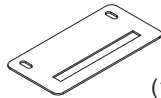

(1) 0176910  
Door catch



(2) 0119468  
Recessed  
bumper

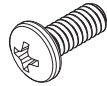

(8) 0190174  
#8 x 3/8" PHMS

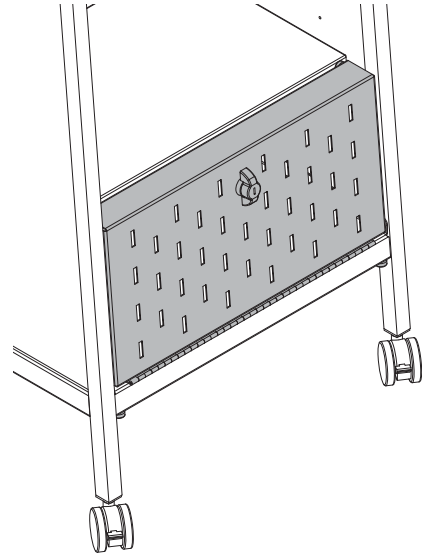

## Locking Door for Aspire Workstation 95044



Assembly tip: Do not tighten component fasteners completely until all have been installed. Keeping them loose will help with alignment between parts during assembly.

### 1 Lower shelf

1. The shelves are included with the Aspire Workstation. Make sure the lower shelf is installed using the 3rd set of holes from the bottom.

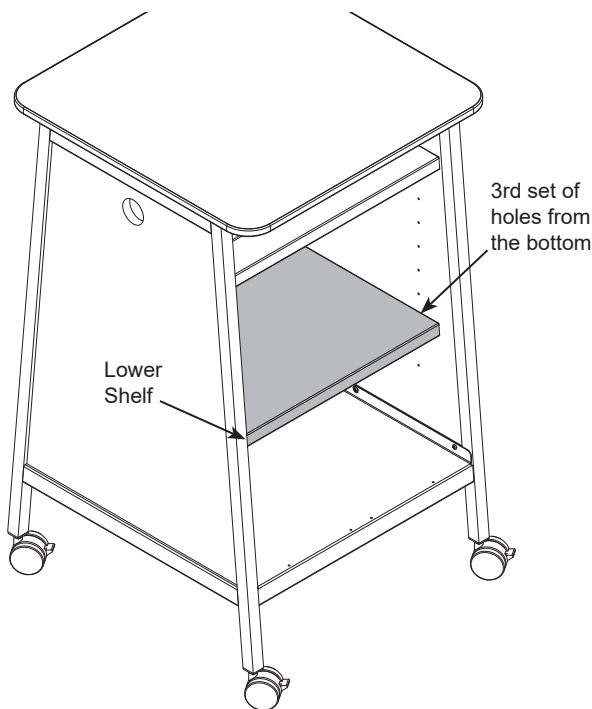

### 2 Install door catch

1. Attach the door catch with (2) screws and tighten securely.

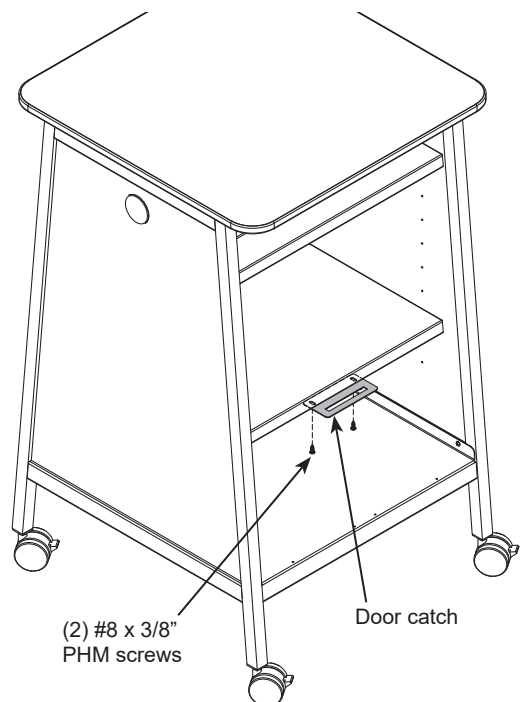

### 3 Install door

1. Open the door hinge and align the hinge mounting holes with the (4) base panel mounting holes.
2. Attach the hinge with (4) screws and tighten securely.
3. Close the door and check the operation of the lock hasp to ensure the hasp fully engages with the slot in the door catch. The catch can be adjusted with the fastener slots if necessary, then retightened..

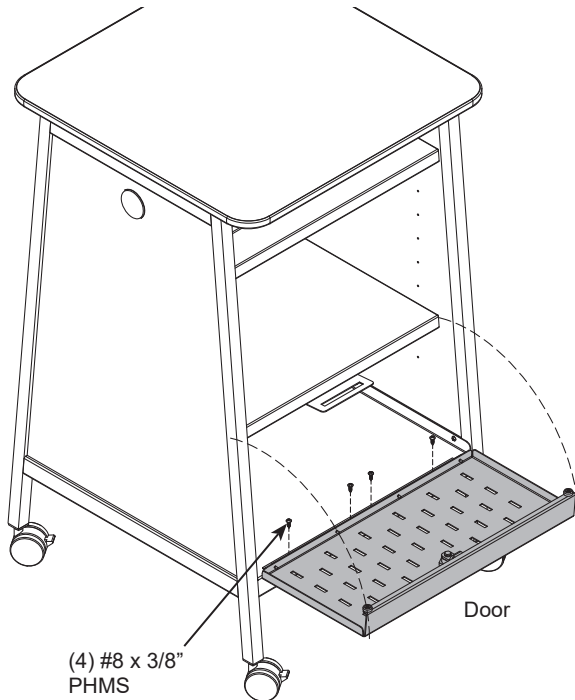

### 4 Install bumpers

1. Install the (2) recessed bumpers under the door. (1) screw each.

