

Technical Specifications

55429

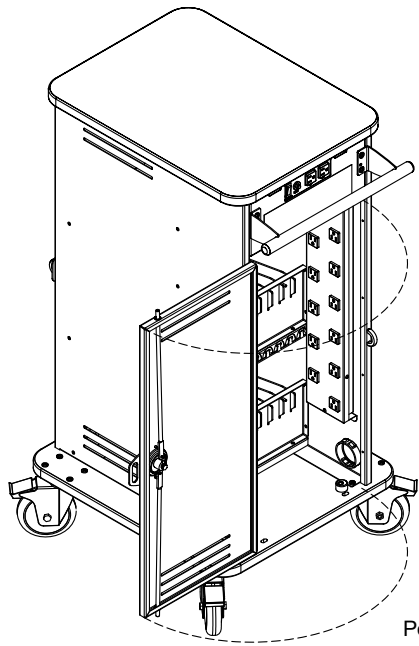

Power side

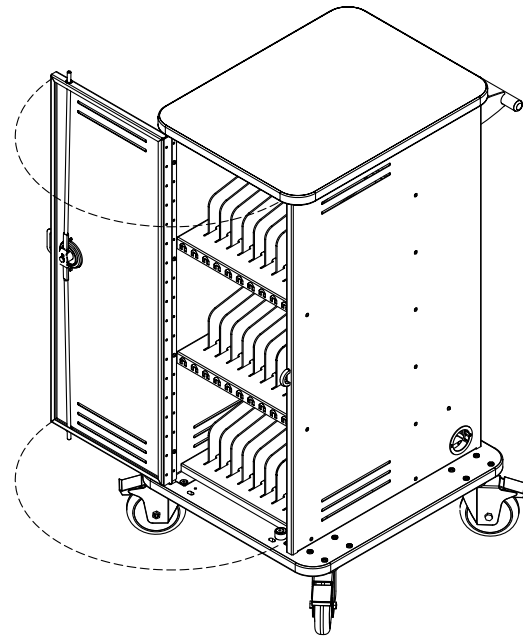

Device side

Use the InTouch32 Cart to store, transport, and charge up to 32 tablets. Padded shelves and flexible dividers protect the tablets. Overhead wire management aids the wiring integration and allows charging plugs to hang in front of each tablet. The cart's compact footprint and handle provide easy mobility. An external switch controls power to the cart and two external auxiliary outlets. The InTouch32 Cart is made with heavy-gauge steel for security and powder-coated for a durable, long-lasting finish. A dual-bolt lock and hasp on each door increase security of the tablets.





Features and Benefits

- Stores, charges, and transports up to 32 tablet computers including iPads® with large cases (up to 1.25" thick)
- 1.25"W x 13.75"D x 10.59"H storage bay accommodates most tablets
- Small cart footprint (20.75"W x 24"D) saves valuable space
- Durable ABS plastic dividers protect devices from scratching (dividers are removable to provide storage space for thicker devices)
- Doors provide easy-access to device and power-side of cart (can be flipped to be hinged from the left or right)
- Double bolt keyed locks and heavy-gauge steel doors provide security
- Hasp locks provide an additional level of security and the ability to use your padlocks of choice (not included), or secure the unit to a wall
- Tablets and students are separated from all line voltage
- Superior, all-metal overhead cord management system keeps charge cords organized above each storage bay
- Junction / power box with a 15-amp breaker, reset button, 8' 3-wire power cord
- Two vertical 16-outlet, (125V~/12A, 60Hz) universal power units work with both inline, and wall adapters
- External power switch provides easy-access for safe power connection / disconnection
- Two external auxiliary outlets (always on) for teacher laptop, WiFi access point, or other accessory
- Ventilated doors and side panels keep tablets and chargers cool, preventing overheating, and extending device life
- Four inboard 5" locking casters provide easy rolling, and quiet transport
- One all steel handle provides control and maneuverability and doubles as a cord wrap
- Worksurface and base panel 3mm vinyl edging protects walls and furniture
- Cart ships fully-assembled with handle for quick, simple integration and deployment
- Durable powder coated steel chassis provides a long-lasting finish
- Scratch and impact-resistant high-pressure laminate top provides a durable, useful worksurface for instructors
- ETL certified to UL 60950-1 in the US and Canada for the cart and electrical system
- Warranted to be free of all defects in materials and workmanship for 10 years, electrical system 2 years
- Designed and assembled in Chippewa Falls, WI, USA

This cart is designed to hold up to 32 tablets.

55429-ABE - 5" Balloon wheels, Power System

Color Options

Laminate: White Fiesta  Metal: Warm Gray 

Construction

- The worksurface and base panel is constructed from 1" thick composite board with .030" high-pressure laminate on one face, and a balancing phenolic backer on the opposing face
- Worksurface and base panel edges are covered with 3mm vinyl edge band
- 16-gauge side panels, shelves, and doors
- All metal components are finished with a scratch-resistant powder coat epoxy
- This cart is factory-assembled, packaged, and shipped on its own skid

Specifications

Capacity	32 tablets	
Storage bays (nominal)	1.25"W [3.17 cm] x 13.75"D [34.92 cm] (13.25"D [33.66cm] at bay directly behind door lock) x 10.59"H [26.91 cm]	
Electrical	<ul style="list-style-type: none"> • (2) 16-outlet power units • 125V~/12A, 60Hz • Externally-accessible 20A power switch (controls <u>all</u> outlets) • Hard-wired junction / power box 	<ul style="list-style-type: none"> • 15-amp breaker with reset button • 2 external auxiliary outlets 1A • 8' nominal 14 AWG, 3-wire power cord • Locking power side door isolates and separates electrical line voltage from students
5" Balloon Wheels	Weight capacity 300 lb [136 kg] each	
Certifications / Compliance	<ul style="list-style-type: none"> • ETL certified to UL 60950-1 	<ul style="list-style-type: none"> • Meets or exceeds applicable ANSI-BIFMA test standards
Unit weight (nominal)	146 lb [66.3 kg]	
Shipping weight (nominal)	181 lb [82.2 kg]	

Specifications subject to change without notice

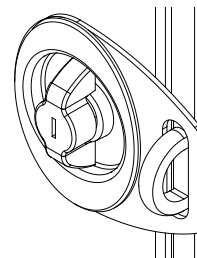
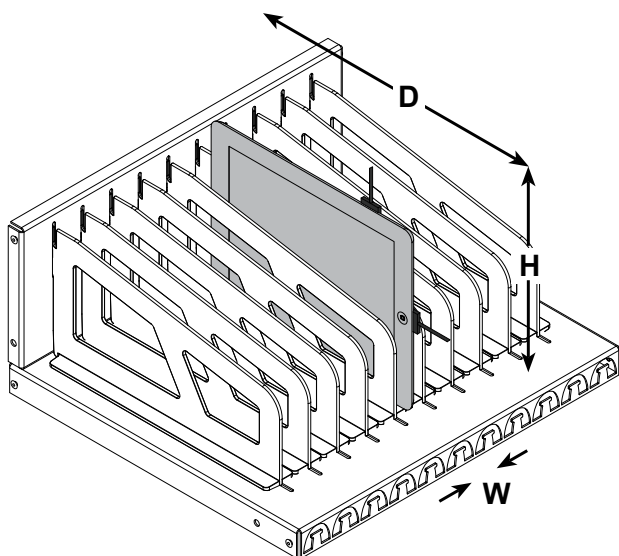

Double-bolt lock with padlock hasp (on both doors)
(padlocks not included)

Devices must be placed in the bays with the charge plug on one of the two edges shown.

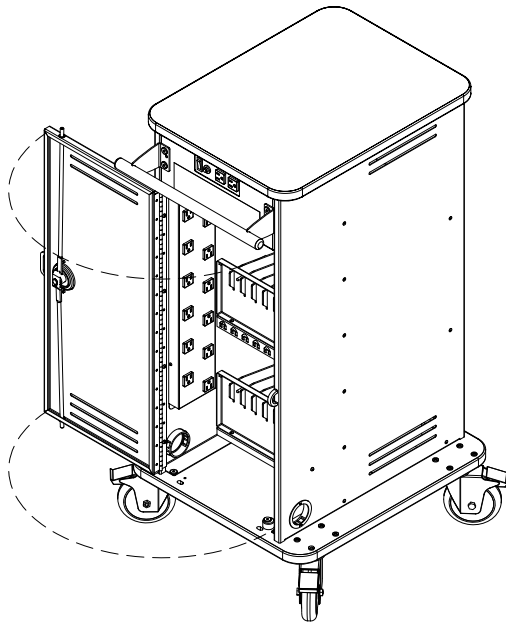

Caster Options

ORDER CODE B = 5" Balloon Wheel

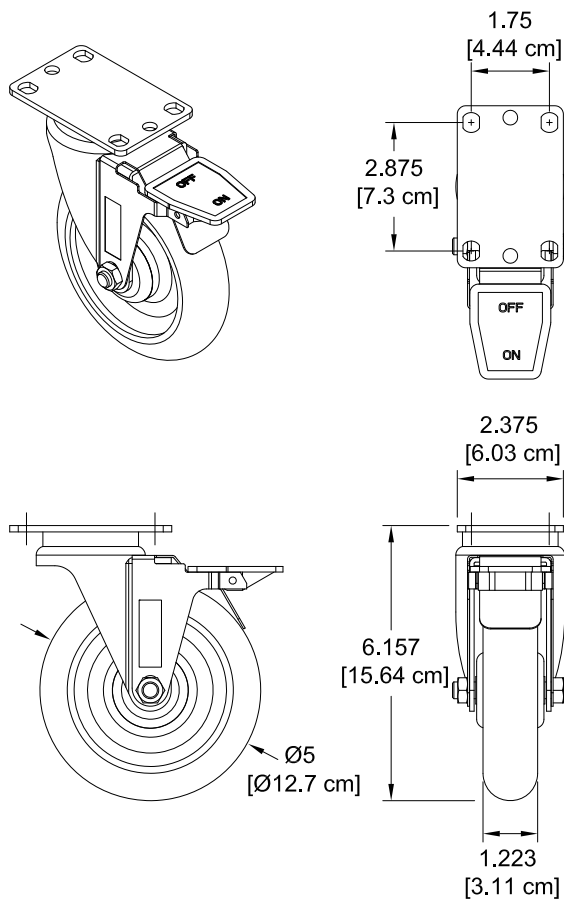

InTouch32 Tablet Cart

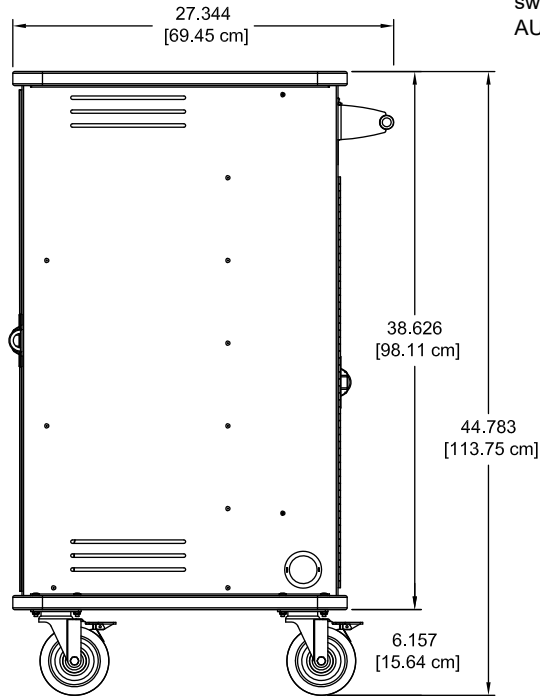
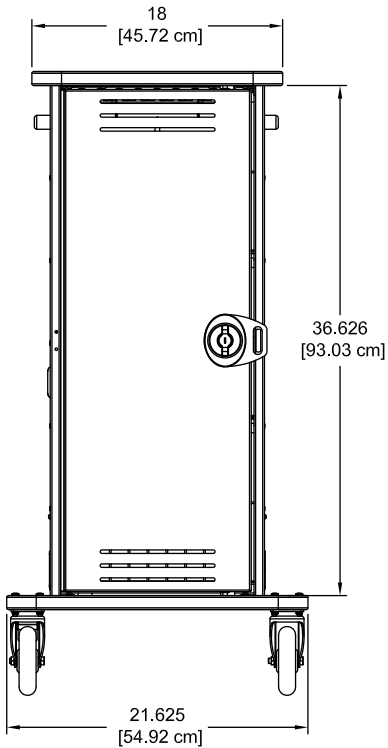
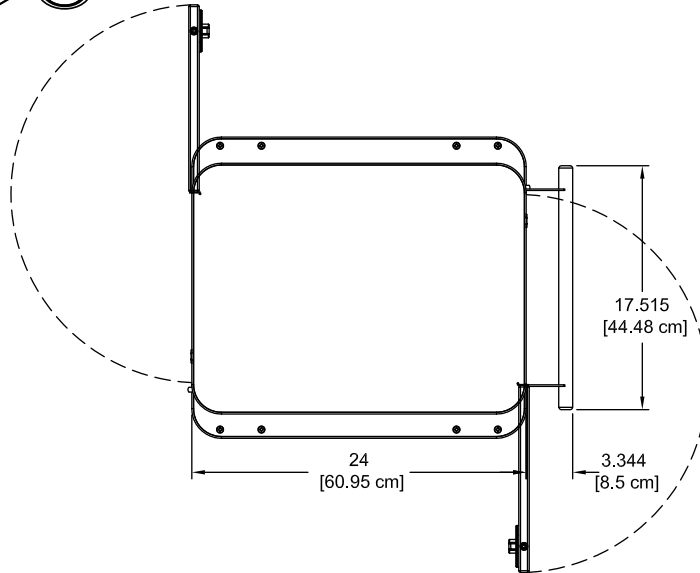
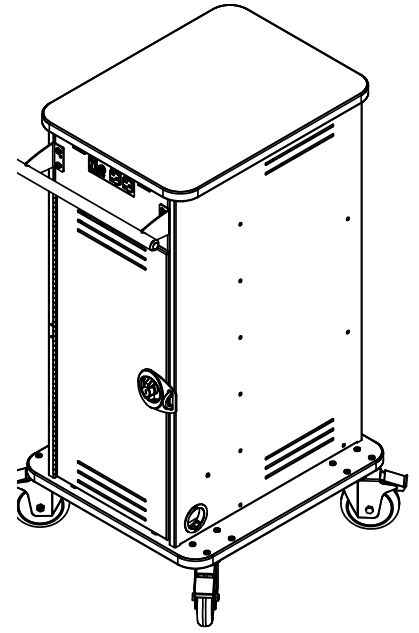
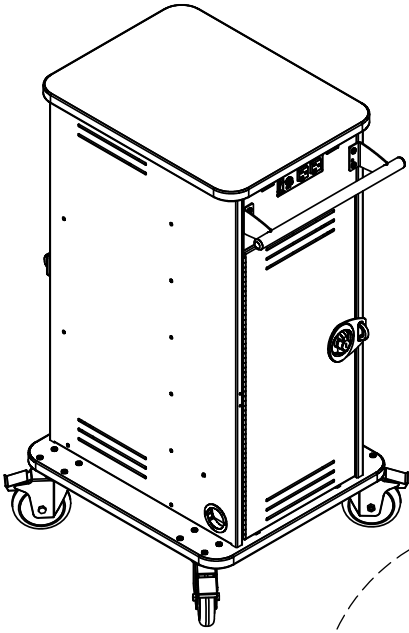

External power switch and 2 AUX outlets

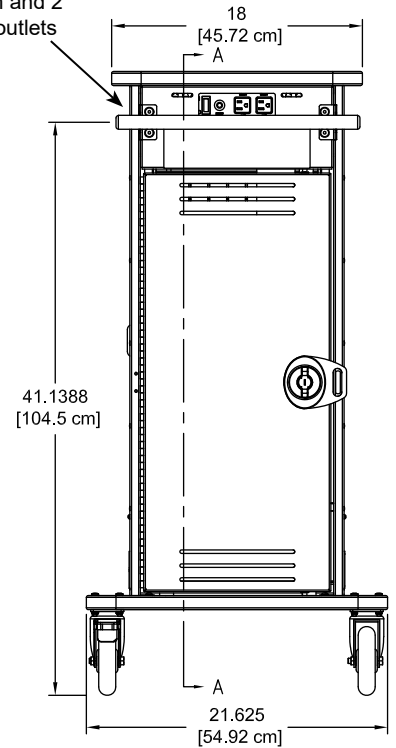

InTouch32
Section view A-A
(shown with common tablet models)

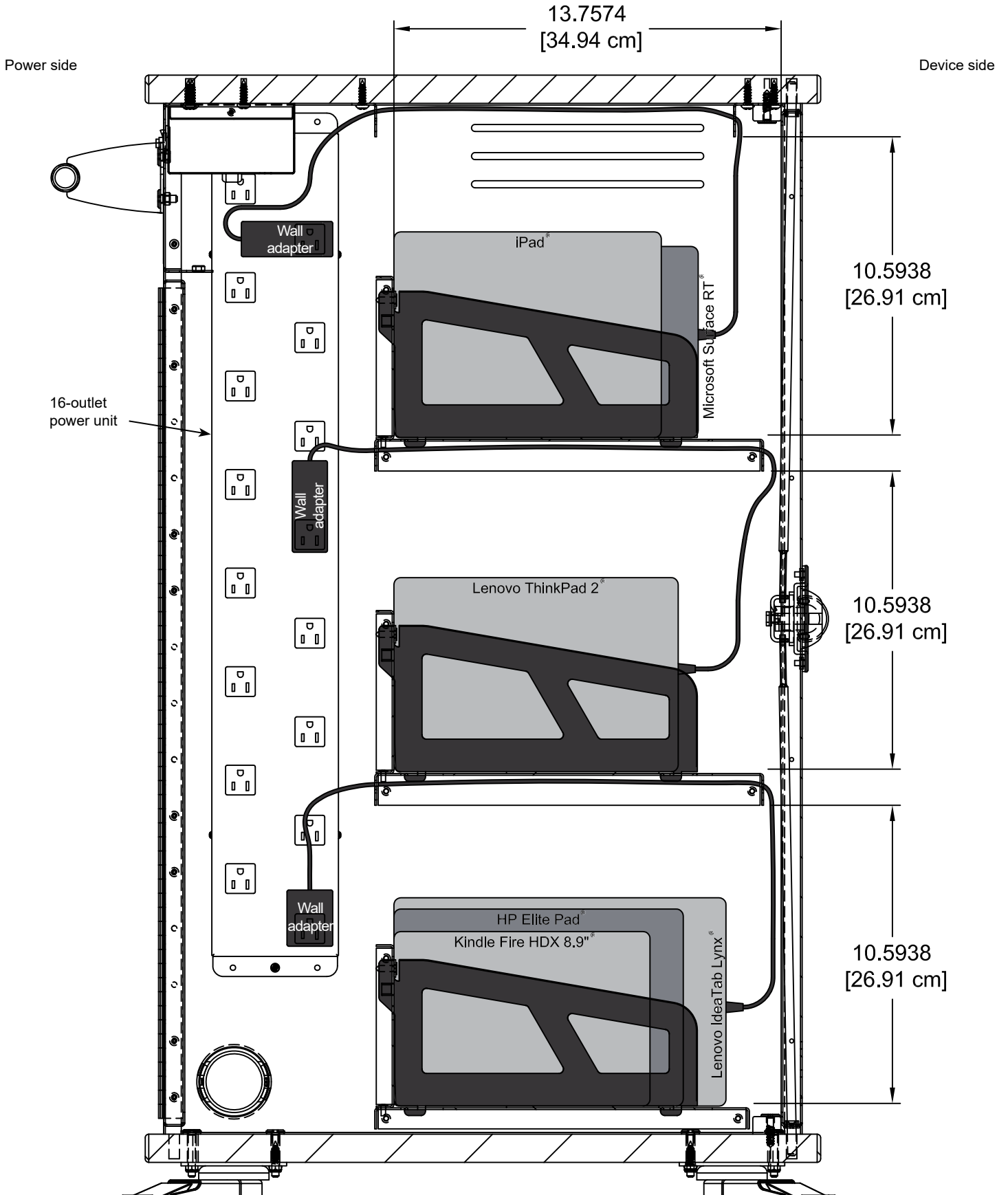

InTouch32
Device side view wiring diagram
(shown without rear door)

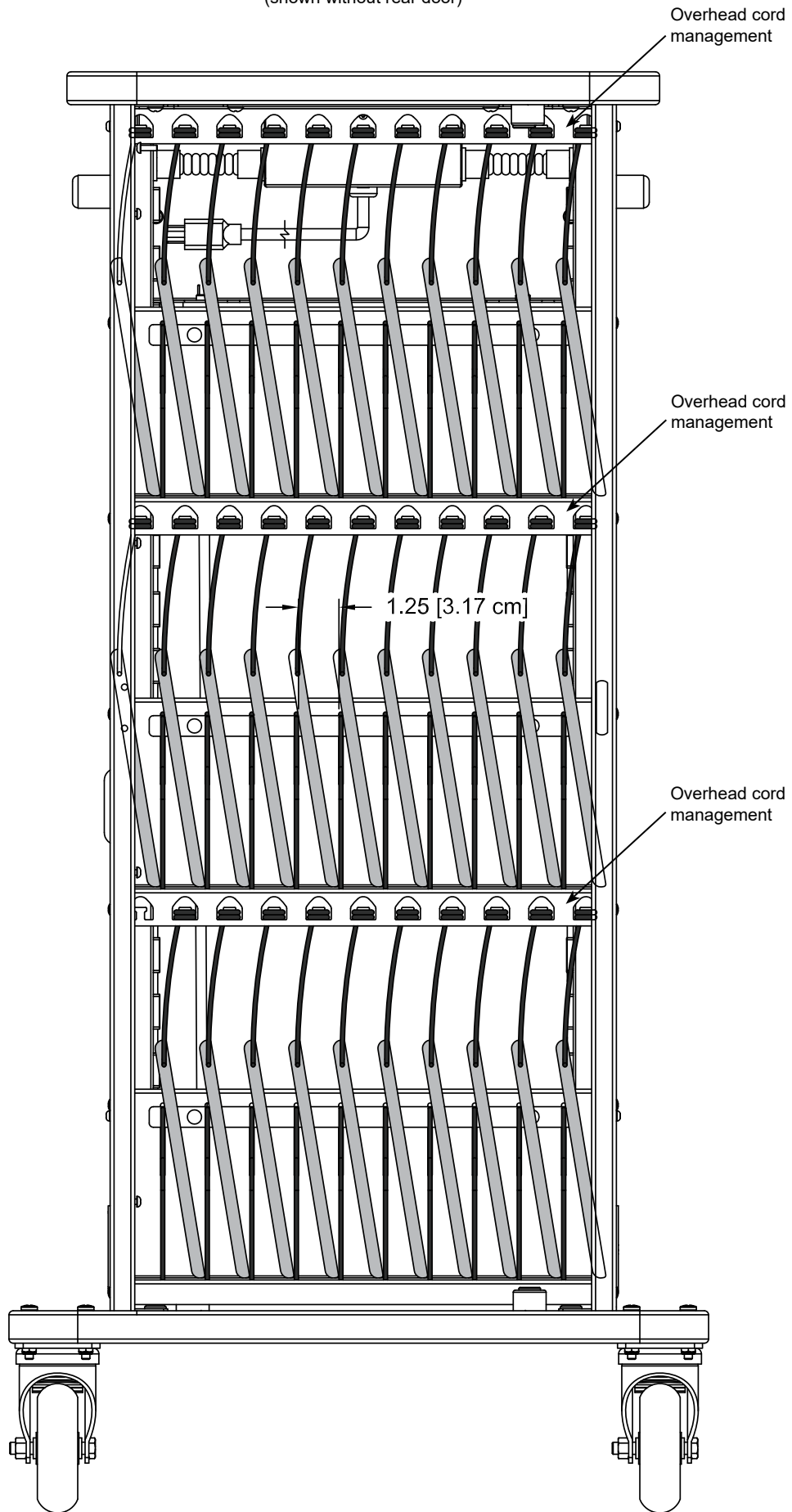

InTouch32
Power side wiring diagram
(shown without door)

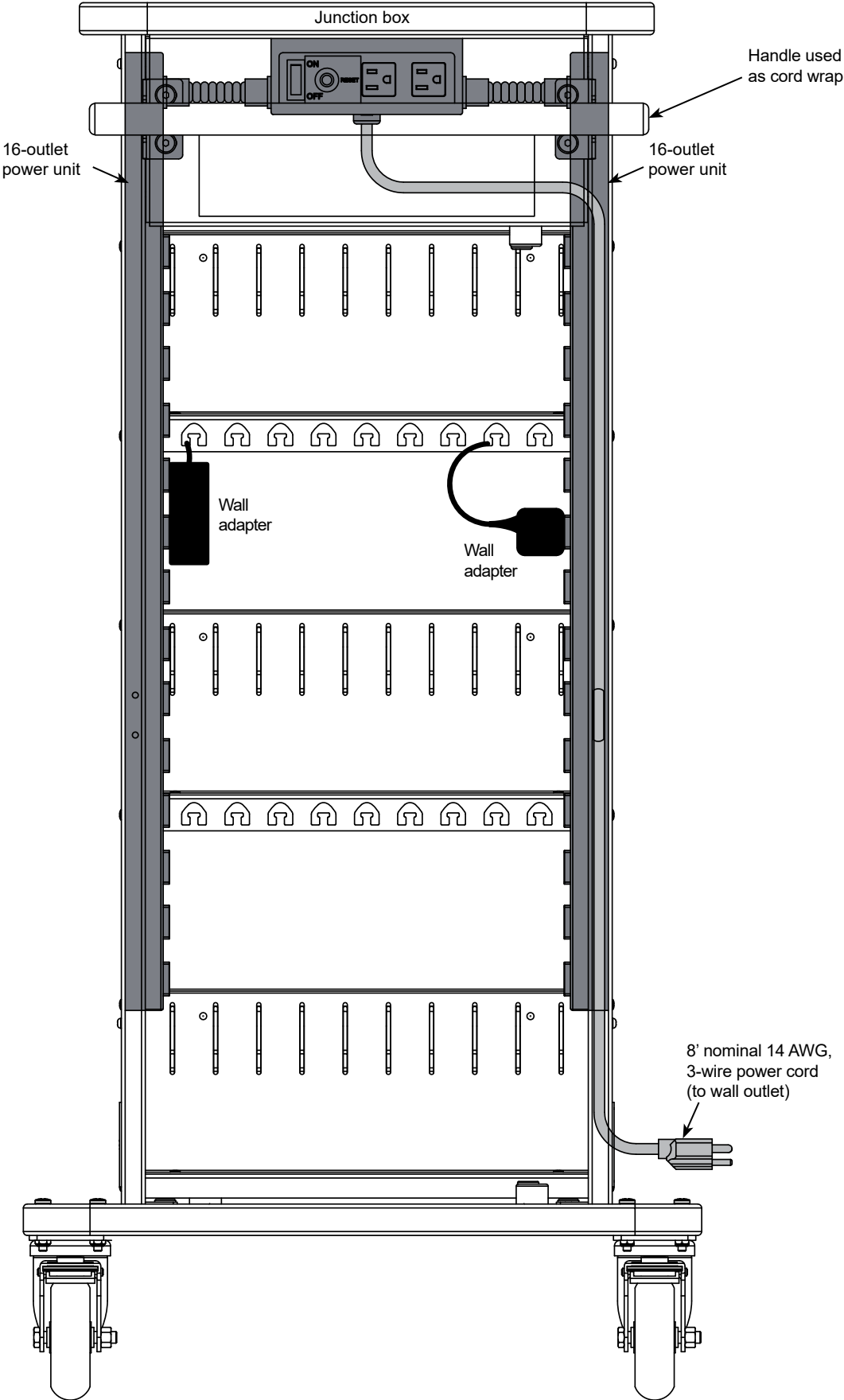

Nominal outlet spacing on each 16-outlet power unit

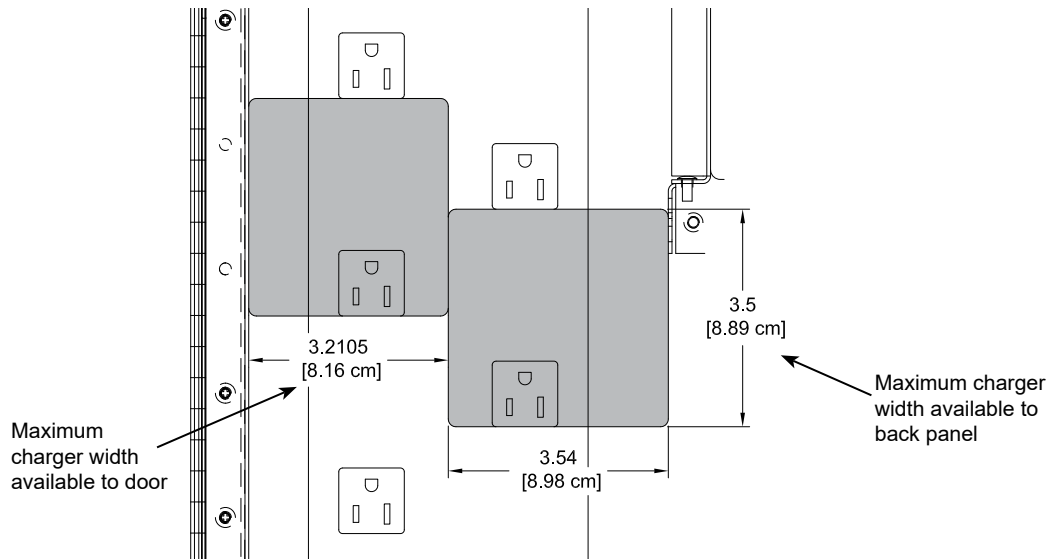

Accessories

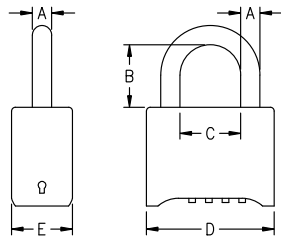

A	.3125" [7.9 mm]
B	1" [25.4 mm]
C	.983" [25 mm]
D	2.07" [52.5 mm]
E	.987" [25.1 mm]

Re-programmable 4-digit Combination Lock - 95536

- Set your own 4-digit personalized combination (up to 10,000 options)
- 5/16" hardened steel shackle for cut-resistance
- Black powdercoated die-cast body for durability
- Change key included
- Unit weight: .55 lb [.25 kg]

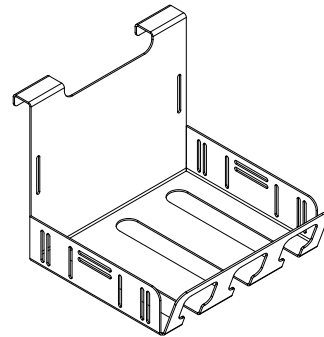

Quickbrick™ Trays for IT32 Cart - 22464

- Removable trays provide fast and easy wiring for quick deployment
- 3 trays included
- Hook and loop retaining straps



Hook-and-loop Strap Kit - 95004

(16) .75" [1.91 cm] x 12" [30.48 cm],
and (32) .75" [1.91 cm] x 5" [12.7 cm]

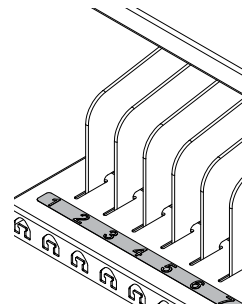

Slot labels for IT32 - 55479

- Black numbers on transparent adhesive backer
- 1-11, 12-22, and 23-32 labels

Warranty

We will make it right for you!

Thanks for choosing Spectrum! Spectrum is committed to provide complete customer satisfaction. Each of our products is manufactured from the best materials available and each product is stringently monitored throughout the production process through our P.A.C.E. program (Product Assurance to meet Customer Expectations).

We expressly warrant that Spectrum products will be of good quality and workmanship and free from defect for the period set out in the warranty from the date of delivery.

For a listing of all product specific warranty terms please visit our website at:

<https://www.spectrumfurniture.com/en/resources/purchasing-terms-warranty>

1-800-235-1262

Toll-free HELPLINE

spectrum@spectrumfurniture.com