

## Technical Specifications

55545

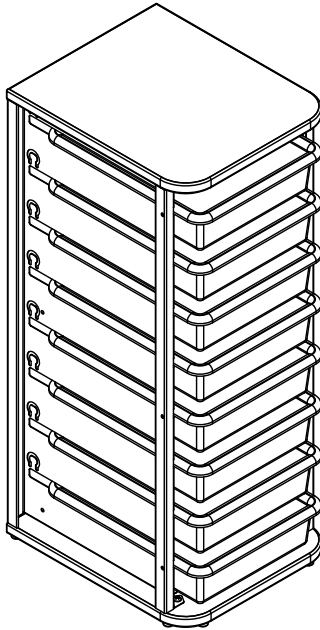

8-Unit  
55545-A1AAS

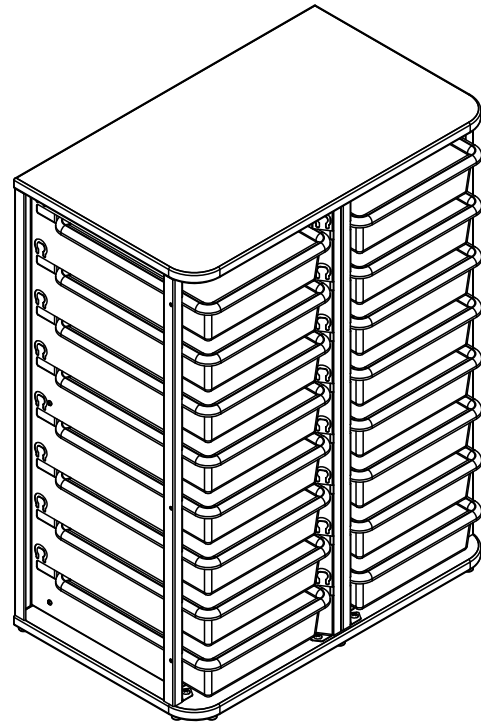

16-Unit  
55545-A2AAS

*The Exploration Station is Spectrum's solution to simplify charging of devices and storage of projects and supplies in one stationary location. Color-coded tote bins with covers provide convenient removable storage. Cord management system keeps cords organized and accessible at each tote bin.*

## Features and Benefits

- Keeps device charging and headphone storage neat and orderly
- Holds up to 8 or 16 devices and headphones in removable tote bins
- Front access cord management system keeps charge cords organized at each tote bin
- Tablets or phones can be charged directly on top of each bin cover
- Removable tote bins can hold individual projects or lessons
- Tote bins come in 4 colors with covers and can be arranged in any order
- Durable top and base panel made from scratch and impact-resistant high-pressure laminate
- Powder coated, heavy-gauge steel construction is built to last
- Available in Steel Mesh laminate and Warm Gray metal
- UL-Listed 8-outlet 120V power strip(s) with 3550 joule surge suppressor and generous outlet spacing accommodate both inline and wall adapters (one on 8-unit, two on 16-unit)
- Ships KD (knocked-down) and requires assembly
- Warranted to be free of all defects in materials and workmanship for 10 years
- Designed and assembled in Chippewa Falls, WI, USA

### Color Options

Metal



Warm  
Gray

Laminate



Steel  
Mesh

# Construction

- The top and base panels are constructed from 3/4" thick composite board with .030" high-pressure laminate on one face, and a balancing phenolic backer on the opposing face.
- Metal components consist of 20-gauge steel
- Top and base panel edges are covered with 3mm vinyl
- All metal components are finished with a scratch-resistant powder coat epoxy
- Each unit is shipped KD (knocked-down) and requires customer assembly.

# Specifications

Tote bin internal area (nominal) (with cover installed)	8.9"W [22.6 cm] x 11.5"D [29.2 cm] x 2.5"H [6.4 cm] <i>Bins are made of drop-resistant plastic</i>	
Electrical (power strip)	<ul style="list-style-type: none"> <li>• 8 outlets with sliding safety covers</li> <li>• Continuous duty: 120V / 15A / 60Hz / 1800W</li> <li>• Surge protection: 3550 Joules</li> <li>• Overload protection</li> <li>• 6' [183 cm] nominal 14 AWG, 3-wire power cord with low-profile plug</li> </ul>	<ul style="list-style-type: none"> <li>• Indicator lights</li> <li>• On/Off switch</li> <li>• Detachable cord management system</li> <li>• Low-profile 1" thin</li> <li>• UL listed</li> </ul>
Unit weight (nominal)	28 lb [12.7 kg] - 8-Unit 56 lb [25.4 kg] - 16-Unit	
Shipping weight (nominal)	30 lb [13.6 kg] - 8-Unit 60 lb [27.2 kg] - 16-Unit	

*Specifications subject to change without notice*

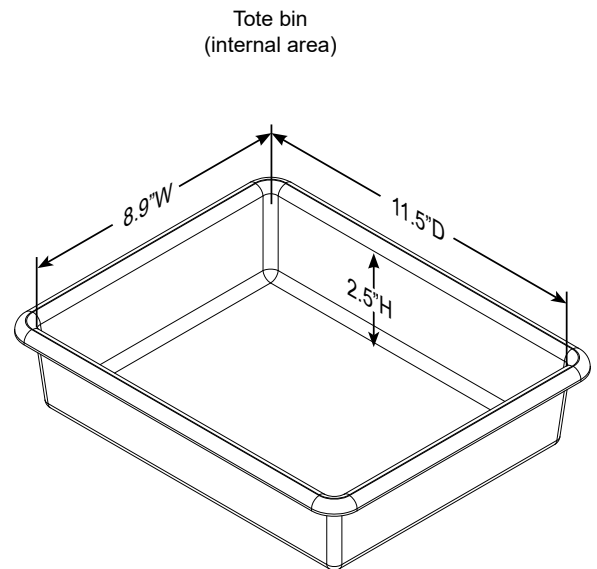
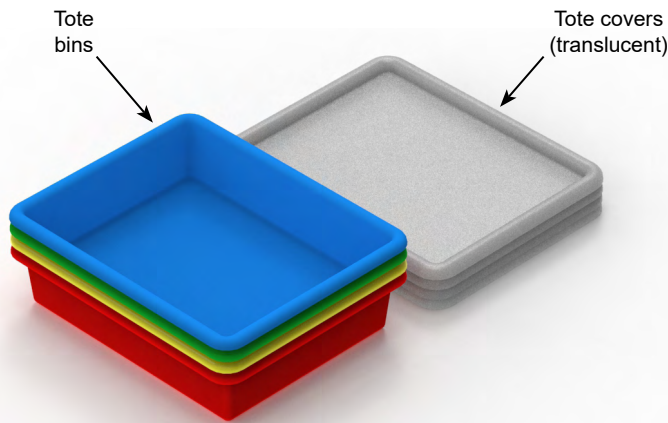

- 10"W [25.4 cm] x 13"D [33 cm] x 3"H [7.6 cm]
- Internal area: 8.9"W [22.6 cm] x 11.5"D [29.2 cm] x 2.5"H [6.4 cm]
- Drop-resistant plastic
- Covers included
- Unit weight (ea): .5 lb [.227 kg]

*Note: Mixed color 8-unit station includes:  
(2) blue, (2) green, (2) yellow, (2) red,  
(8) Translucent covers*

*Note: Mixed color 16-unit station includes:  
(4) blue, (4) green, (4) yellow, (4) red,  
(16) Translucent covers*



16-Unit



**55545-A2AASBL**  
16-unit w/ blue bins



**55545-A2AASGR**  
16-unit w/ green bins



**55545-A2AASRD**  
16-unit w/ red bins



**55545-A2AASYL**  
16-unit w/ yellow bins



**55545-A2AAS**  
16-unit w/ mixed bins

---

8-Unit



**55545-A1AASBL**  
8-unit w/ blue bins



**55545-A1AASGR**  
8-unit w/ green bins



**55545-A1AASRD**  
8-unit w/ red bins



**55545-A1AASYL**  
8-unit w/ yellow bins



**55545-A1AAS**  
8-unit w/ mixed bins

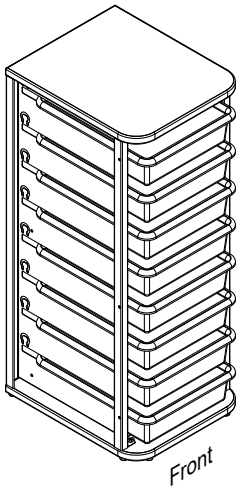

Front

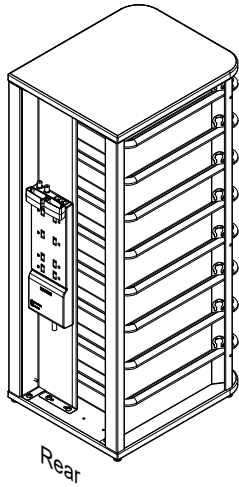

Rear

8-Unit

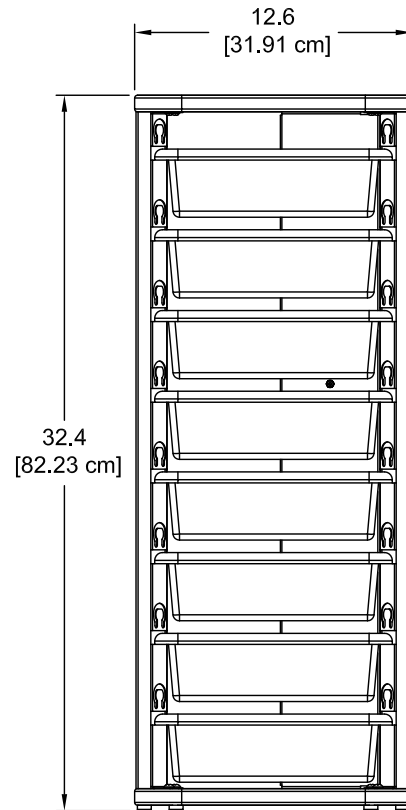
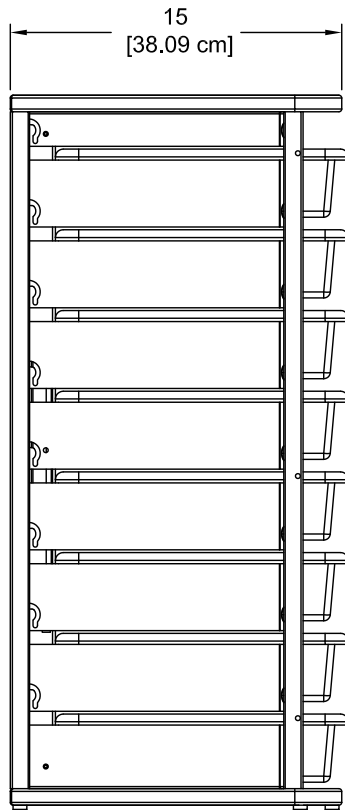
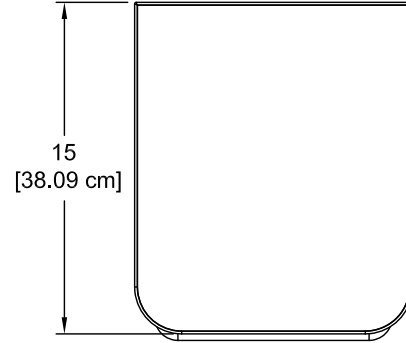

16-Unit

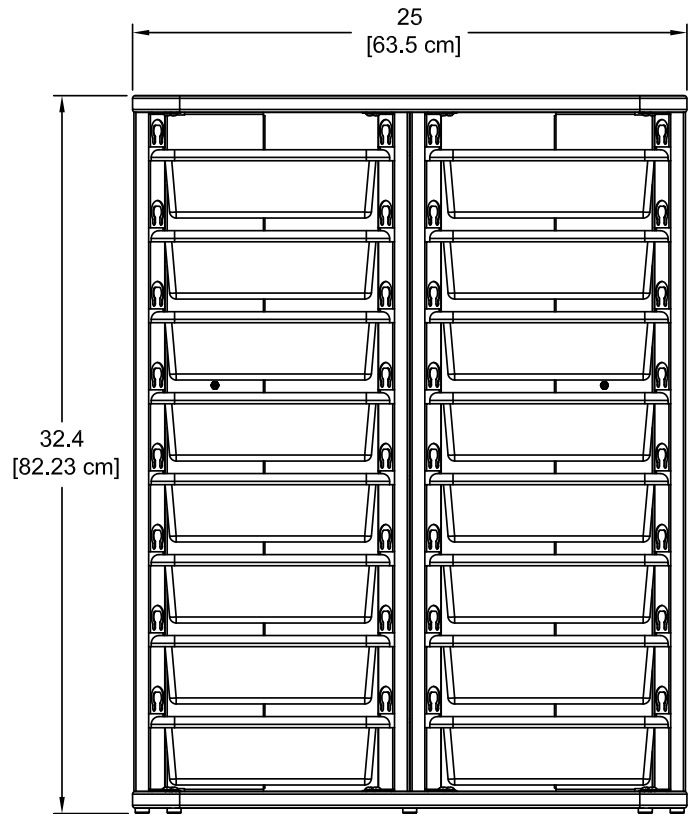
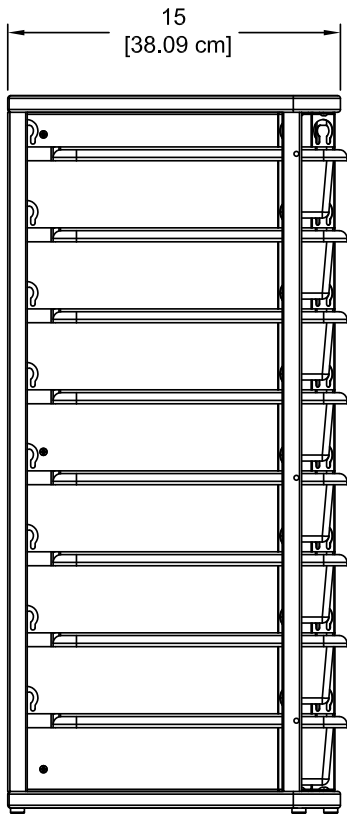
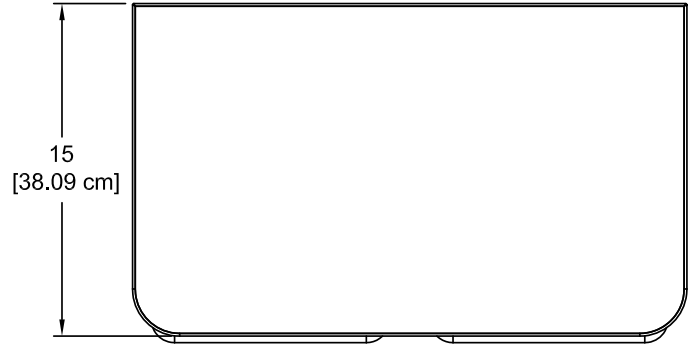
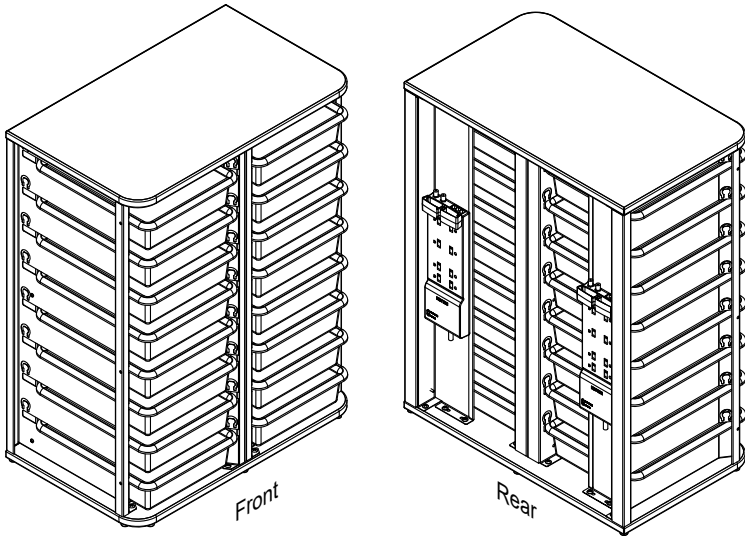

8-outlet, surge-suppressed  
power strip  
(one or two included)

Nominal outlet spacing on  
each 8-outlet power strip

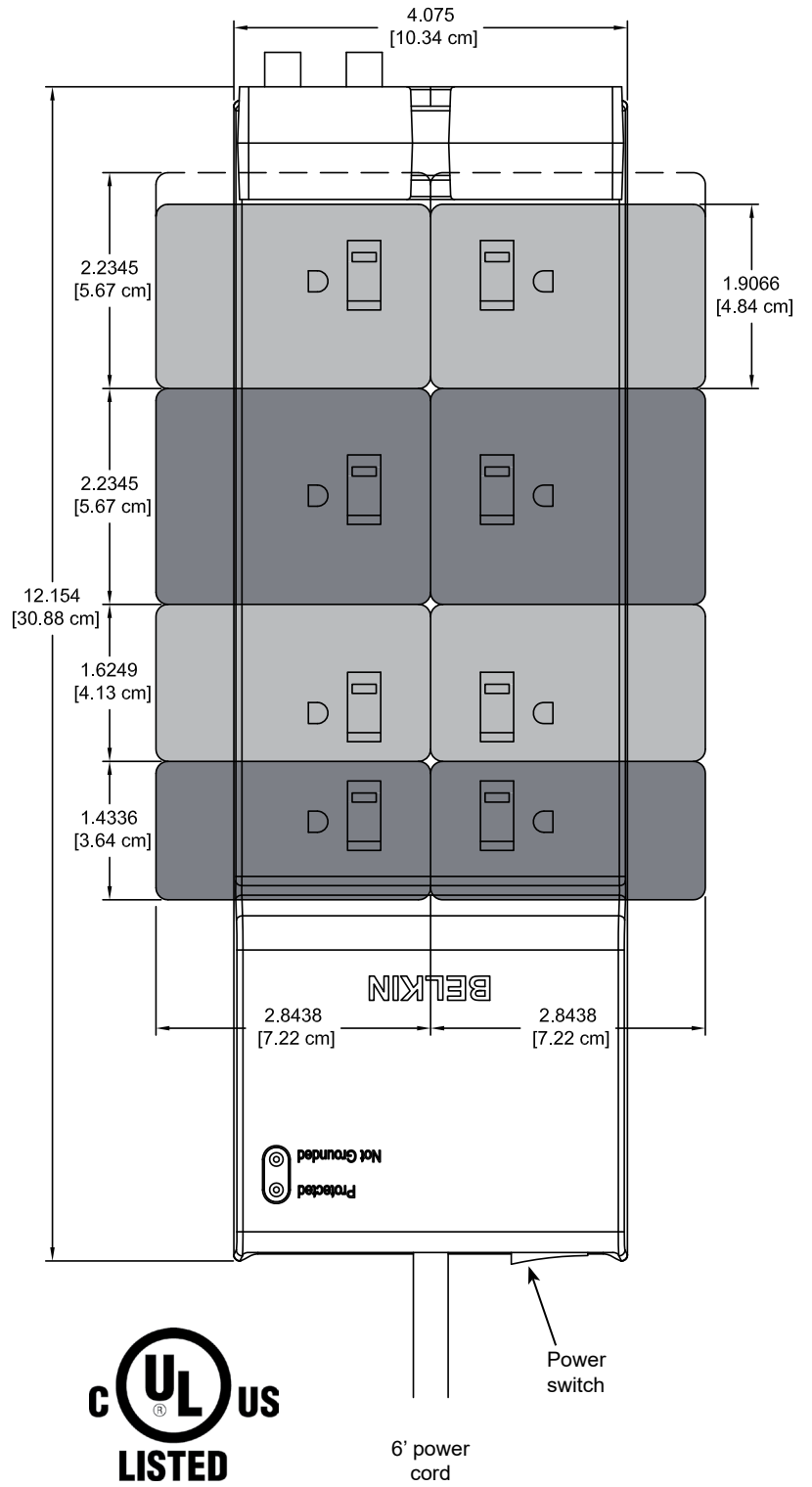
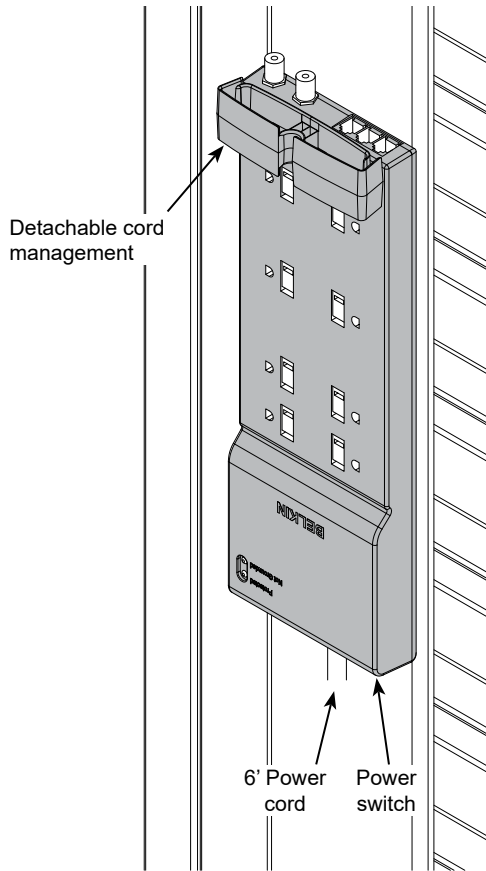

## Warranty

### **We will make it right for you!**

Thanks for choosing Spectrum! Spectrum is committed to provide complete customer satisfaction. Each of our products is manufactured from the best materials available and each product is stringently monitored throughout the production process through our P.A.C.E. program (Product Assurance to meet Customer Expectations).

We expressly warrant that Spectrum products will be of good quality and workmanship and free from defect for the period set out in the warranty from the date of delivery.

**For a listing of all product specific warranty terms please visit our website at:**

<https://www.spectrumfurniture.com/en/resources/purchasing-terms-warranty>

**1-800-235-1262**

Toll-free HELPLINE

**[spectrum@spectrumfurniture.com](mailto:spectrum@spectrumfurniture.com)**