

Technical Specifications

37319

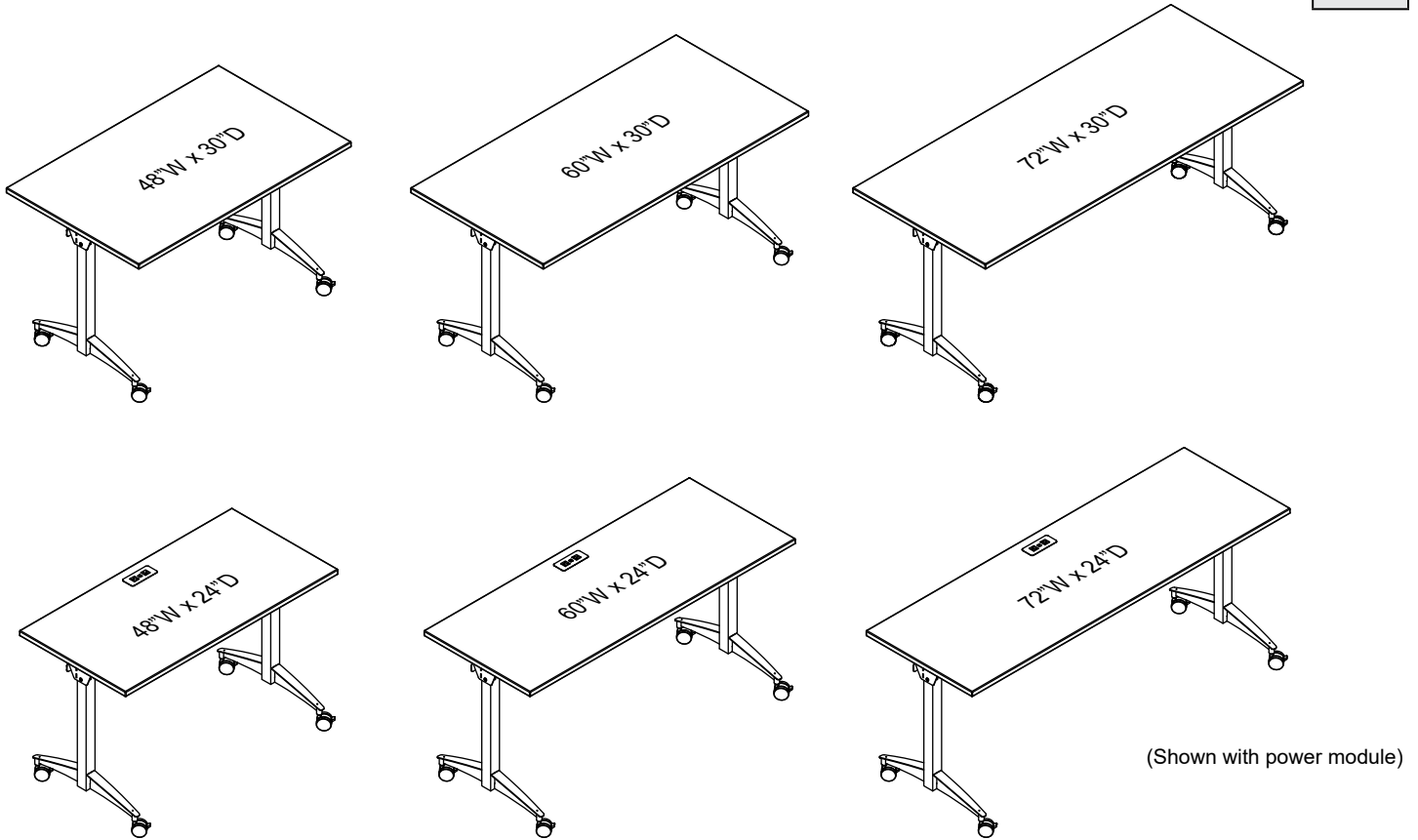

Spectrum's Flex Active™ Flip Tables were designed with room reconfiguration in mind. The flip-up design frees up valuable space while the casters provide quick and easy reconfiguring of any room. These durable, all-purpose collaborative/training tables are designed for use in a wide variety of applications such as training/conference rooms, classrooms, and computer labs.

Features and Benefits

- Available in 72", 60", and 48" wide versions
- Available in 30" or 24" depths (24" depth is ideal for laptop use or when space is limited)
- 30"H scratch and impact-resistant high-pressure laminate worksurface
- Durable powder coated steel legs provide a long-lasting finish
- Locking casters provide easy rolling room reconfiguration
- Matching vinyl edge trim on worksurface edges protect walls and furniture (some laminate choices use non-matching edge trim)
- Optional Power Module with AC power plug (requires worksurface cutout)
- Optional Easy Power (hardwired) Connection Kit with Power Module (requires worksurface cutout)
- Optional low-profile rubber unit-to-unit draw latches make it easy to reconfigure rooms and secure tables together
- Standard laminate colors available to match existing furniture
- Table ships "knocked-down" for lower shipping costs and can be easily assembled at the final location
- Warranted to be free of all defects in materials and workmanship for 10 years
- Designed and assembled in Chippewa Falls, WI, USA

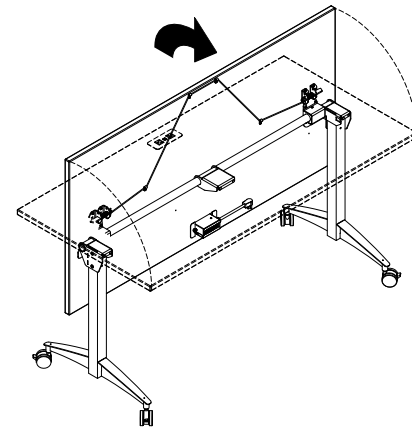

Color Options

Available in Spectrum Expressions colors. See spectrumfurniture.com for complete color information.

Ordering Instructions

Spectrum has designed this product to receive the useful options shown here. To ensure your options are ordered correctly please call 1-800-235-1262.

Construction

- The worksurface is constructed from 1" thick NAF (no added formaldehyde) composite board with .030" [.762mm] high-pressure laminate on one face, and a balancing phenolic backer on the opposing face
- Worksurface edges are covered with vinyl edgeband
- Legs made from 16-gauge square tubing
- Base components consist of 7-gauge steel
- All metal components are finished with a scratch-resistant powder coat epoxy
- Release cable is black braided steel
- Flip mechanisms are powder coated black
- All tables are shipped knocked-down (KD) and require assembly
- Bulk packaging available for quantities of 8 or more. Access to a truck-height loading dock, forklift, liftgate truck, or other means of unloading a heavy shipment is needed.

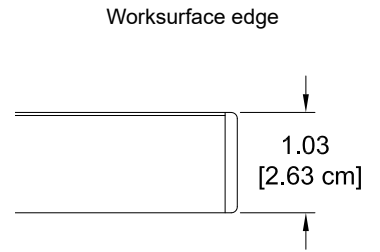

Specifications

Sizes available	24"D	30"D
	48"W [121.92 cm] x 24"D [61 cm]	48"W [121.92 cm] x 30"D [76.2 cm]
	60"W [152.4 cm] x 24"D [61 cm]	60"W [152.4 cm] x 30"D [76.2 cm]
	72"W [182.88 cm] x 24"D [61 cm]	72"W [182.88 cm] x 30"D [76.2 cm]
Worksurface height	30"H with casters	
Casters (<i>caster-versions only</i>)	Soft polyurethane, twin wheel with brake Weight capacity: 90 lb [40.9 kg] each	
Seating	48"W - 1 person 60"W - 2 people 72"W - 2 people	
ADA-compliance*	 1 ADA seat per table <small>*Minimum ADA guidelines for knee clearances are 30"W x 19"D x 27"H</small>	
Certifications / Compliance	• Meets or exceeds applicable ANSI-BIFMA test standards	
Unit weight (nominal)	59 lb [26.8 kg] - 48"W x 24"D 71 lb [32.2 kg] - 60"W x 24"D 80 lb [36.3 kg] - 72"W x 24"D	71 lb [32.2 kg] - 48"W x 30"D 83 lb [37.7 kg] - 60"W x 30"D 96 lb [43.6 kg] - 72"W x 30"D
Shipping weight (nominal)	67 lb [30.4 kg] - 48"W x 24"D 79 lb [35.9 kg] - 60"W x 24"D 88 lb [40 kg] - 72"W x 24"D	79 lb [35.9 kg] - 48"W x 30"D 91 lb [41.3 kg] - 60"W x 30"D 104 lb [47.2 kg] - 72"W x 30"D

Bulk packaging available for quantities of 8 or more. Access to a truck-height loading dock, forklift, liftgate truck, or other means of unloading a heavy shipment is needed. Note: Weights of bulk packed tables will vary

Specifications subject to change without notice

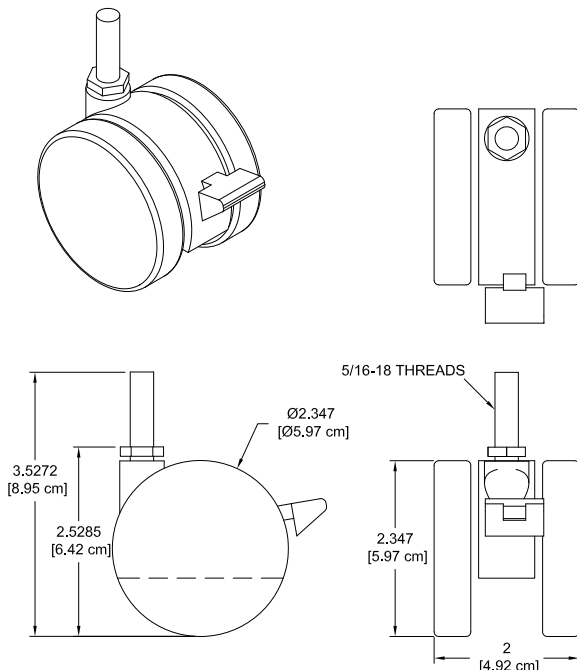

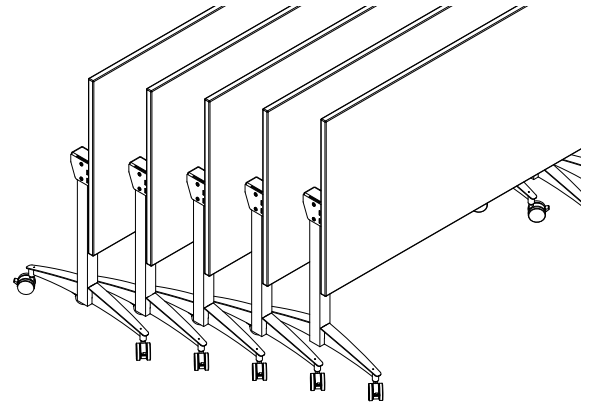
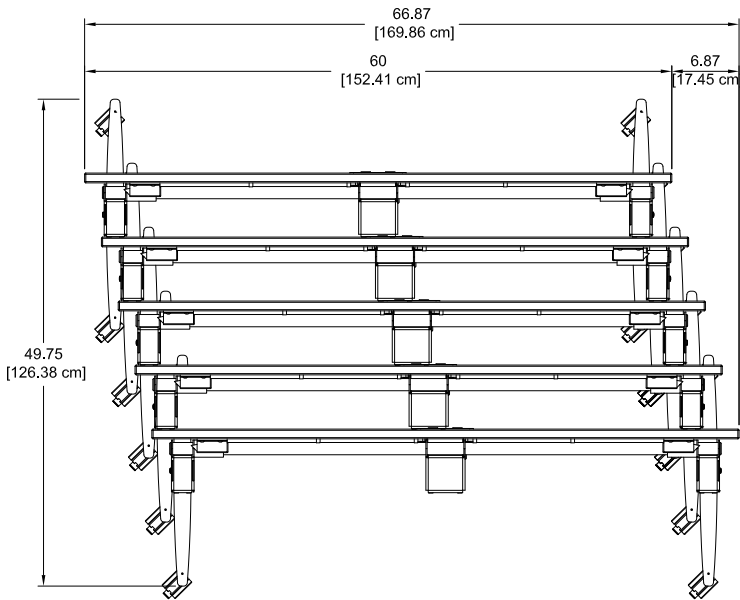

Note: Plastic bumpers are included to protect laminate worksurfaces when nested.

Flipped dimensions

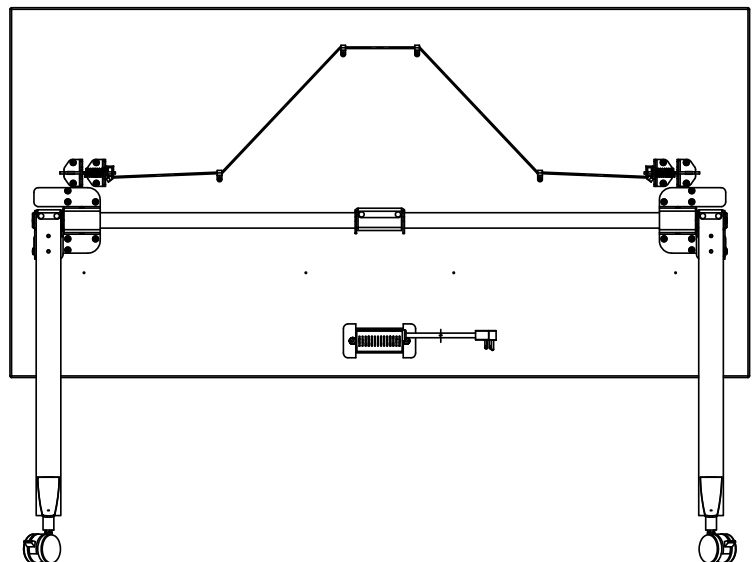
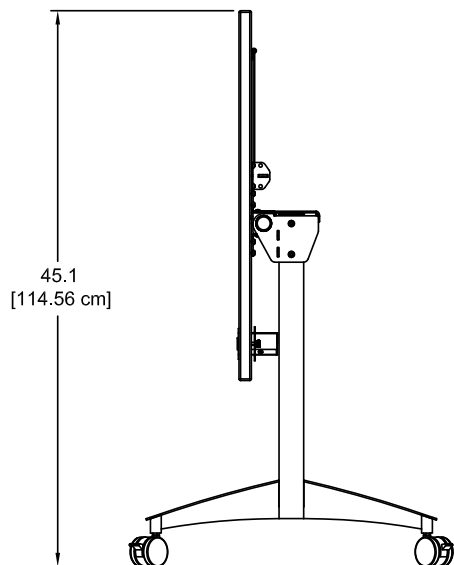
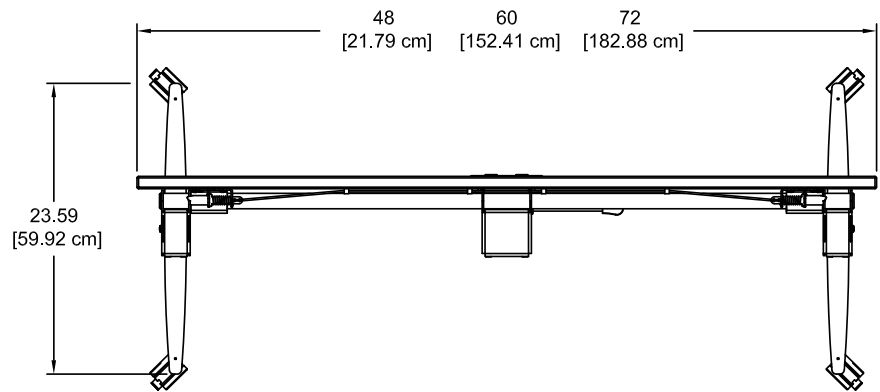

ORDER CODE A = 48"W x 24"D

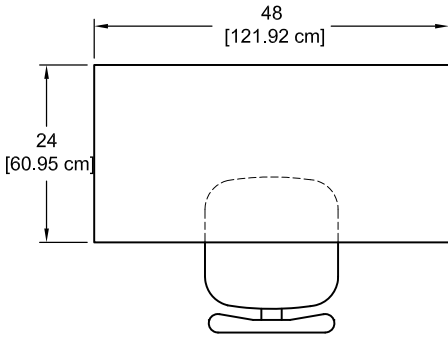

ORDER CODE B = 48"W x 30"D

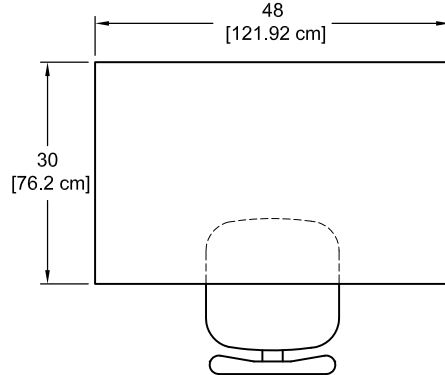

Note: 48"W tables are not wide enough for two people in most situations. Spectrum recommends a 60" or 72"W table to accommodate two people.

ORDER CODE C = 60"W x 24"D

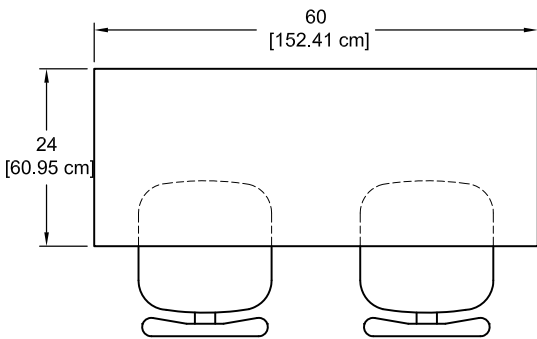

ORDER CODE D = 60"W x 30"D

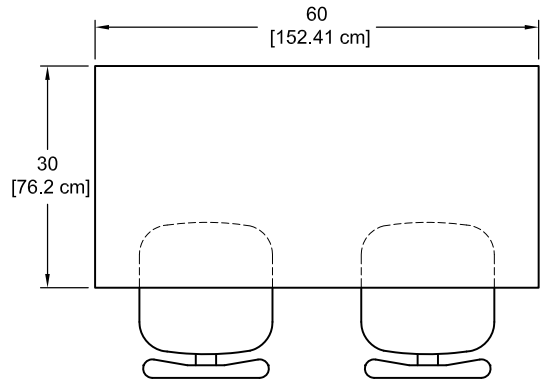

ORDER CODE E = 72"W x 24"D

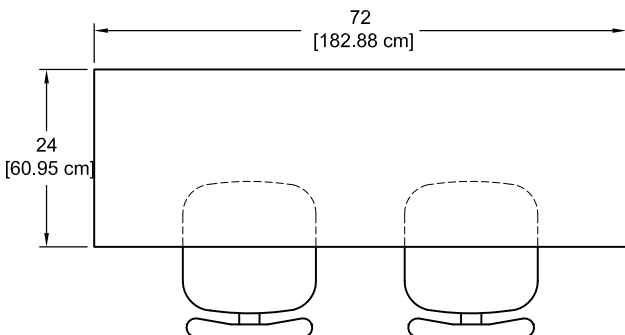

ORDER CODE F = 72"W x 30"D

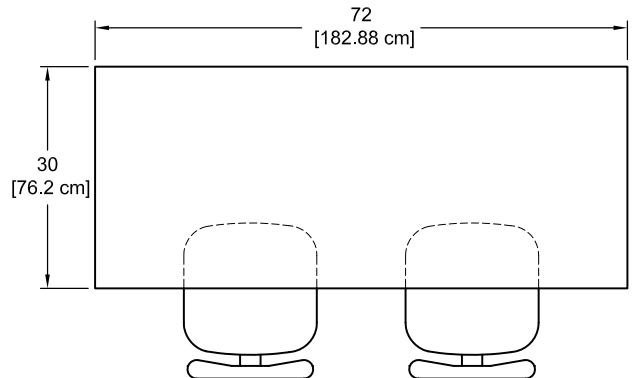

ORDER CODE 0 =	None
----------------	------

1 Power Module

ORDER CODE 4 =	Black Power Module
ORDER CODE 3 =	Silver Power Module
ORDER CODE 8 =	White Power Module

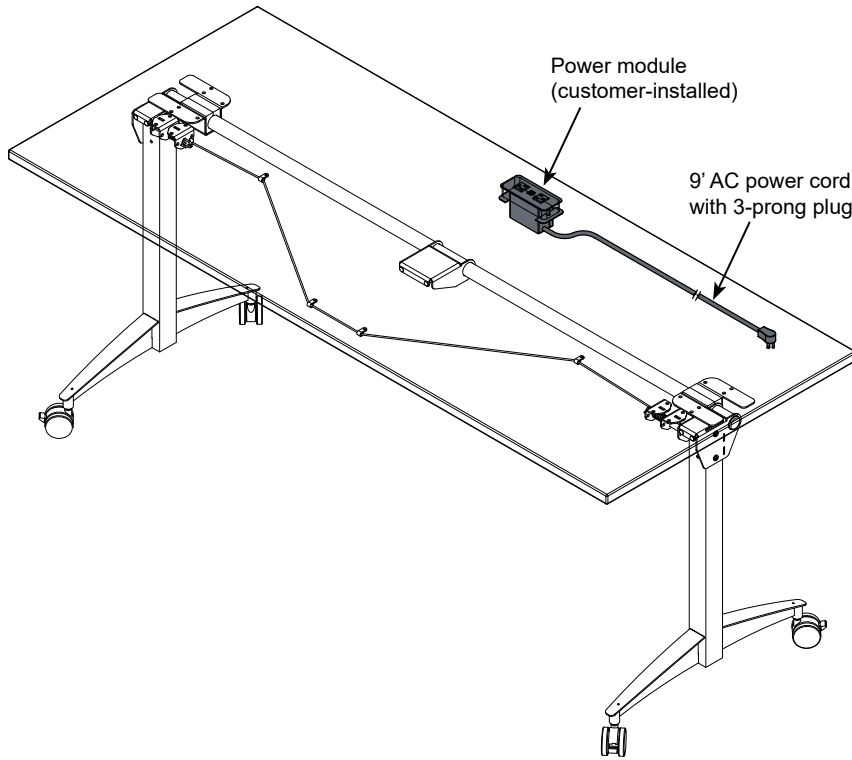
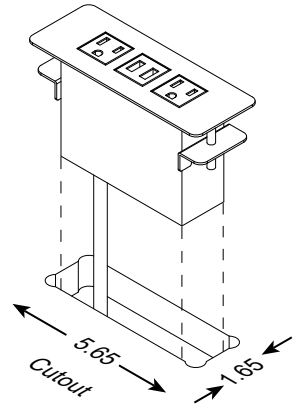

Worksurface cutout
(provided when configured)

- Factory-installed
- (2) AC receptacles (tamper-resistant)
- (2) USB ports rated at 2.1A each (10.5 watts)
- Aluminum housing and flange
- 9' 14AWG *3C power cord
- When specified, the Power Module is centered on the audience-side edge of the worksurface
- Worksurface cutout size: 5.65"W x 1.65"D
- ETL-certified

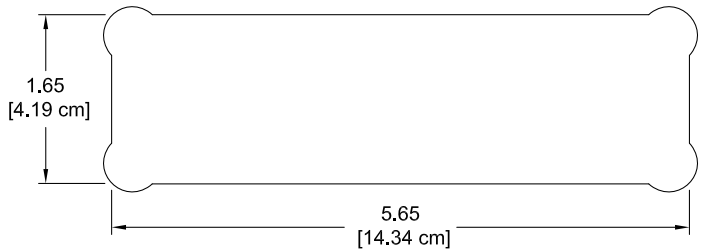

Black



Silver



White



2 Cove™ Power Module w/ Easy Power Kit

ORDER CODE 5 =	Black Cove Module w/ Easy Power Kit
ORDER CODE 6 =	Silver Cove Module w/ Easy Power Kit



- Each power connection kit accommodates one table
- Two AC power receptacles
- Two USB charge ports (not data-compatible)
- Worksurface includes 5.25"W x 2"D worksurface cutout
- Flexible metal conduit is secured to worksurface underside
- Starter connects to standard 3-prong wall outlet
- Cove is ETL listed
- Thumbscrew clamps
- Cove available in Black or Silver

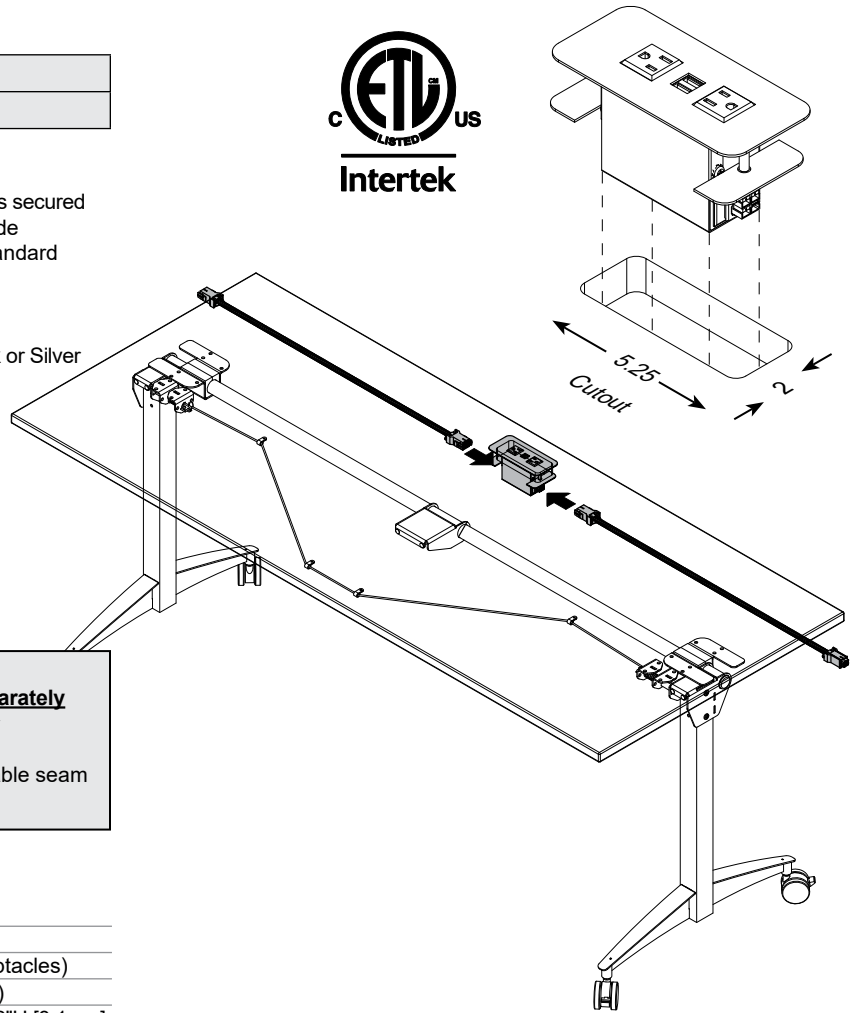

- Each power connection kit accommodates one table
- **Each row of tables requires (1) 99050 starter-order separately**
- Typical installations should not exceed 6 or 7 Easy Power Connection Kits (or tables) per row (or circuit).
- (One) Unit-to-unit latch 37238 is recommended at each table seam when this option is used on connected tables.

Cutout required:	5.25"W [13.3 cm] x 2"D [5.1 cm]
Power cord:	15A
Power receptacles:	12A, 120 VAC spill-resistant (2 receptacles)
USB charging ports:	2.1A (10.5W) (2 USB charging ports)
Cove dimensions:	6"W [15.2 cm] x 2.5"D [6.35 cm] x 3.18"H [8.1 cm]

Cove Power Module available in Black or Silver

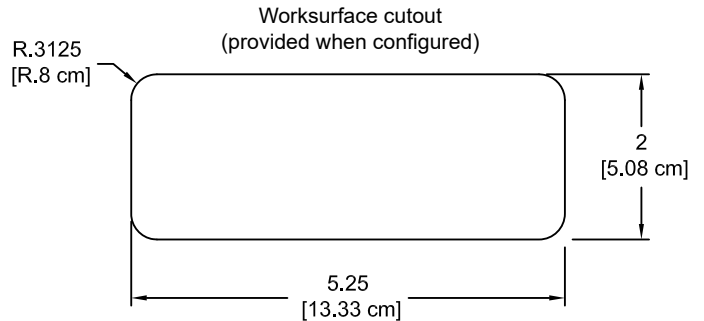

99050 - Starter Kit (Sold Separately)

(One required per row)
72" [183 cm], 20-15A

To wall outlet

Note: The starter cable can be routed through the leg to the floor.

3 EM Wireless Charging Pad

ORDER CODE F = EM Wireless Charging Pad

- Uses electromagnetic technology to charge Qi V1.2 compliant IC devices ("Qi" enabled)
- LED to confirm pairing / charging
- Security tab prevents theft
- Includes 3" round cutout
- UL-certified

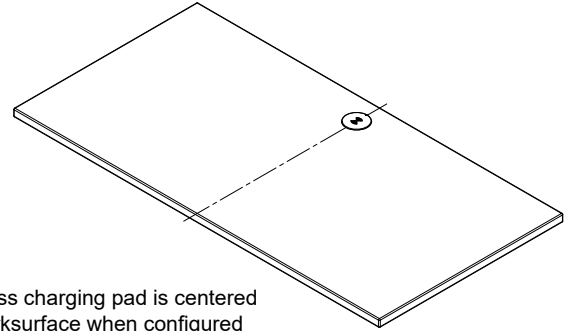
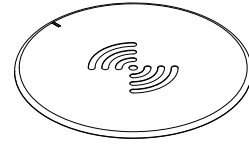

Wireless charging pad is centered on worksurface when configured

Packaging options

ORDER CODE S =	Single pack
ORDER CODE B =	Bulk pack (8 or more)

Note: Flex Active Tables are available in bulk pack quantities of 8 or more. Although there is cost-savings of consolidating into bulk packaging, access to a truck-height loading dock, forklift, or other means of unloading the pallets from the truck is necessary.

48"W Flex Active Flip Table

Shown with optional power module

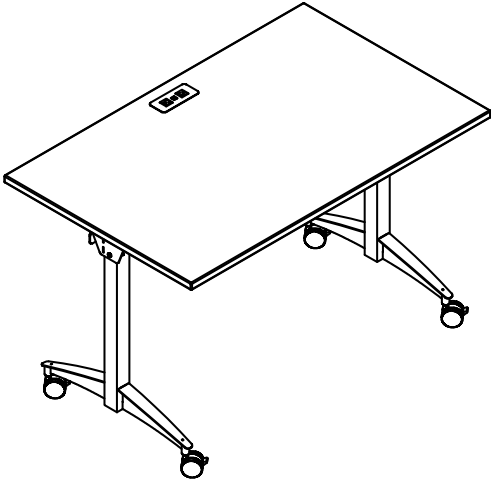

Note: 48"W tables are not wide enough for two people in most situations. Spectrum recommends a 60" or 72"W table to accommodate two people.

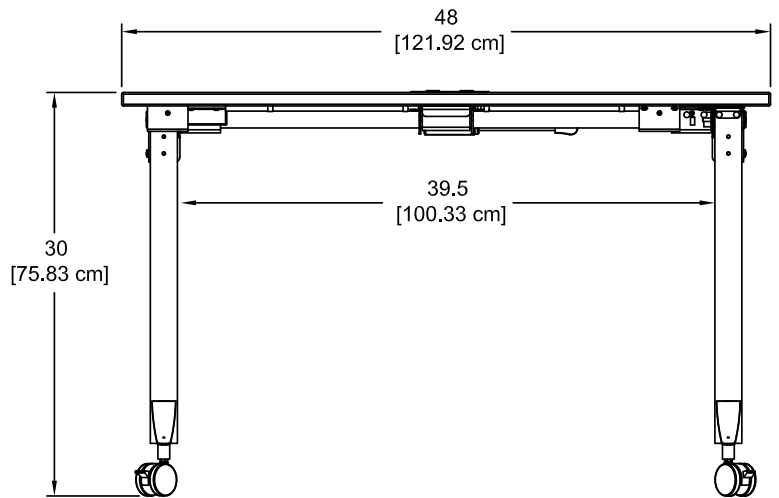
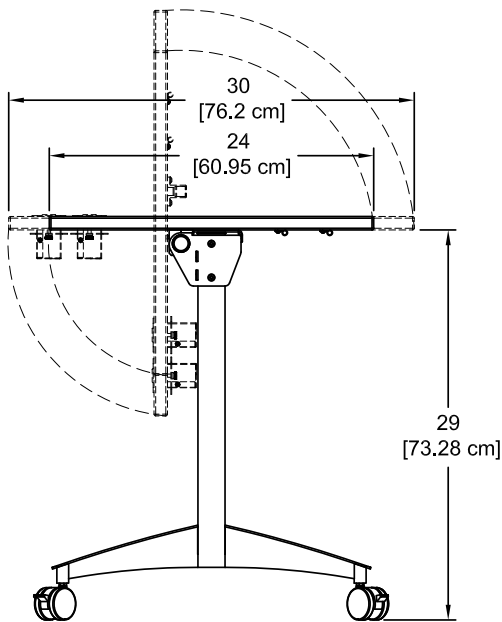
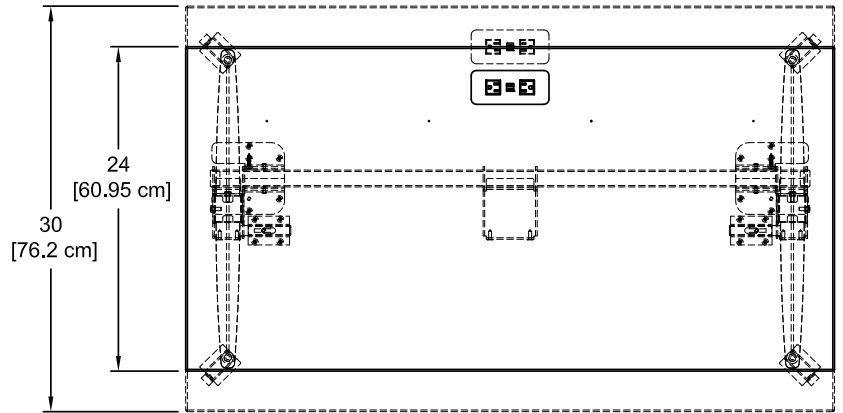

60"W Flex Active Flip Table

Shown with optional power module

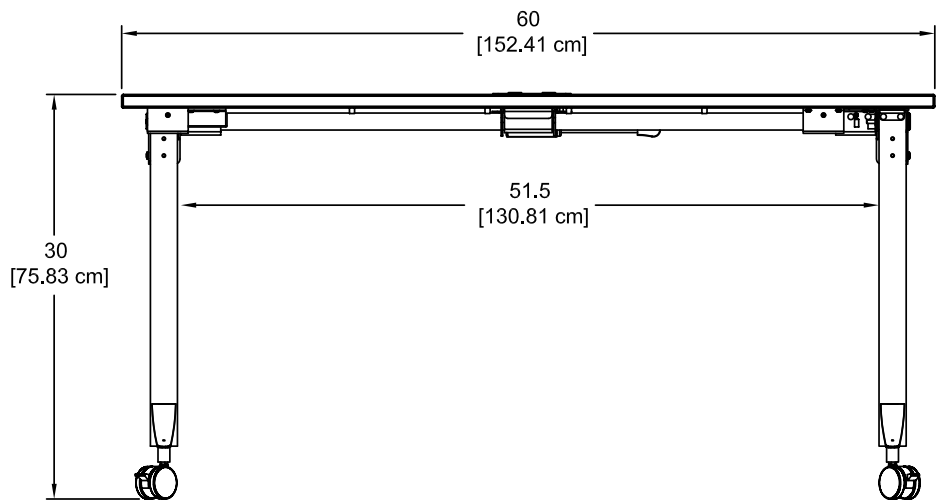
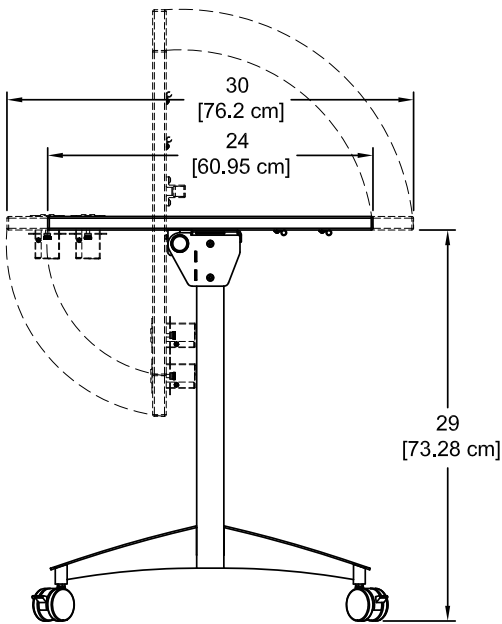
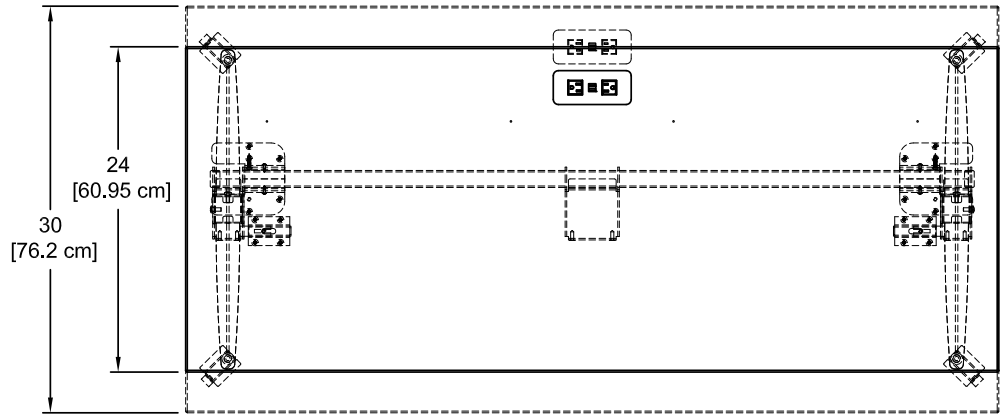
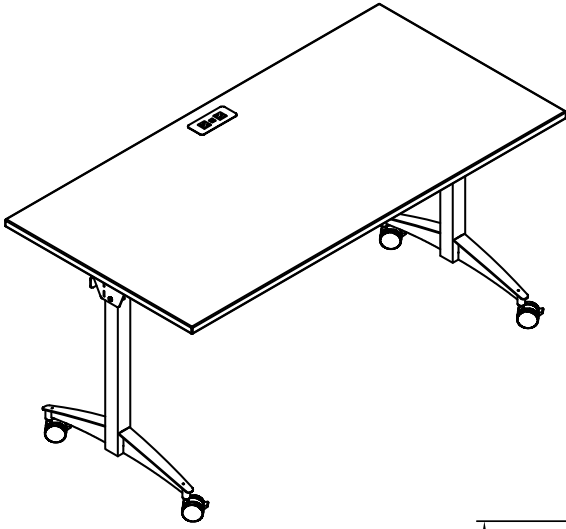

72"W Flex Active Flip Table

Shown with optional power module

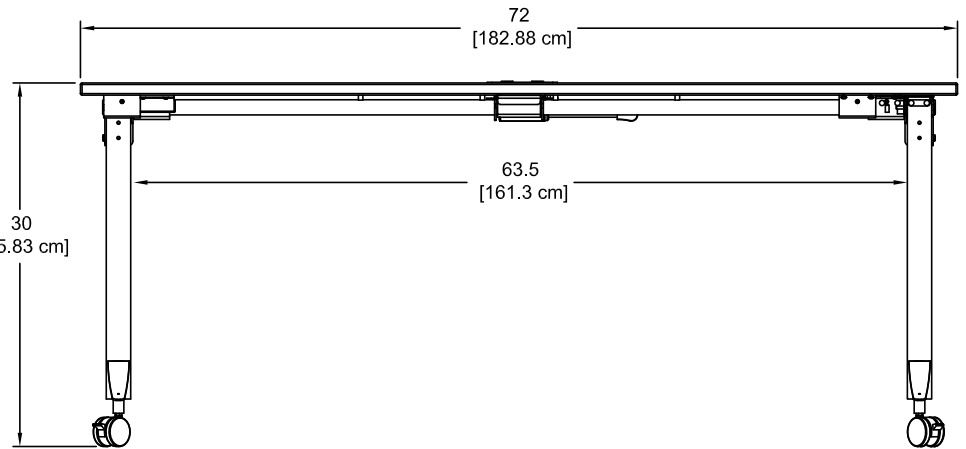
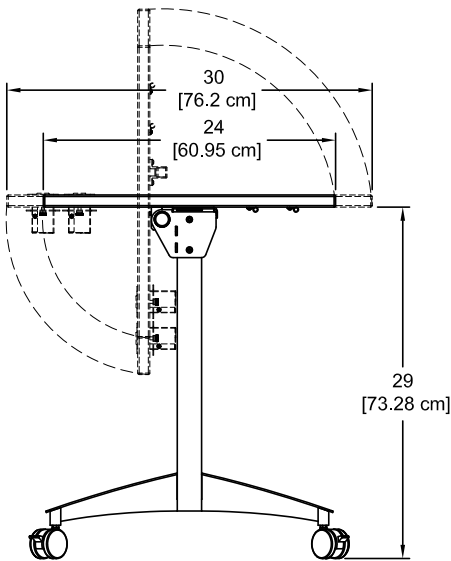
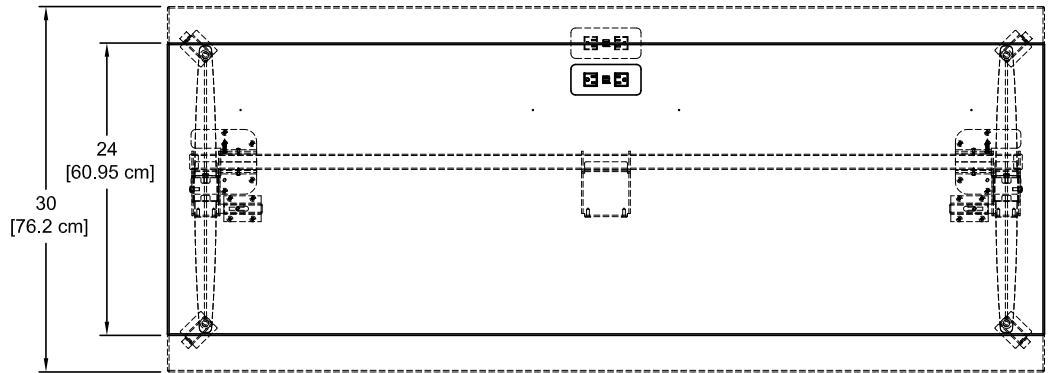
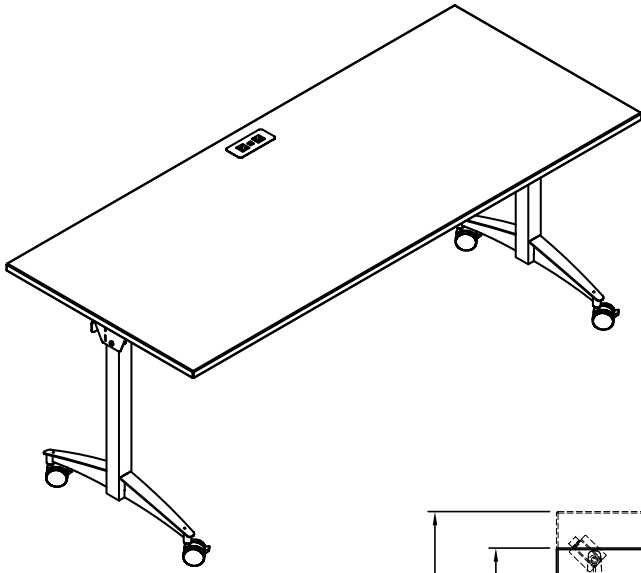

Accessories

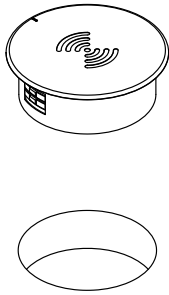

Note: The unit requires a 7" diameter of clearance to work with Qi-enabled phones placed in any orientation. The 3" dia cutout should be located on the worksurface at least 3.5" from any edge.

EM Wireless Charging Pad - 99057

- Uses electromagnetic technology to charge Qi V1.2 compliant IC devices ("Qi" enabled)
- LED to confirm pairing / charging
- Security tab prevents theft
- Customer-installed
- UL-certified

Cutout required:	3" dia (by customer)
Input:	DC 5V (with included DC5V.2A power adapter)
Output:	5W max (with included DC5V.2A power adapter)
Power cord:	8' [244 cm] with DC jack
Dimensions:	3.5" dia [8.9 cm] x 1.125"H [2.9 cm]
Shipping weight:	1 lb [.45 kg]

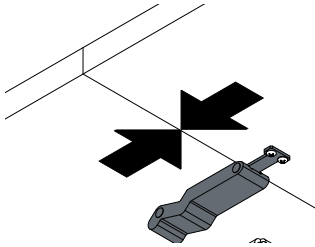

Ganging latch - 37238

- Low profile and made of flexible rubber
- (1) Latch required per seam
- Fasteners included

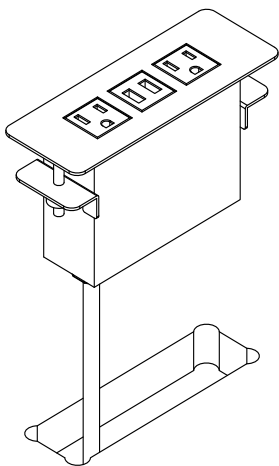

Power Module - 99058

- (2) AC power outlets
- (2) USB charge ports
- Aluminum housing and flange
- Thumbscrew clamps
- Requires worksurface cutout made by customer
- ETL-certified
- Available in black, silver, or white
- Customer-installed

Cutout required:	5.65"W [14.35 cm] x 1.65"D [4.19 cm]
Power cord:	10' [305 cm] 14AWG *3C power cord
Power receptacles:	125V, 60hz, 15A tamper-resistant
USB charging ports:	2.1A (10.5W) (not data-compatible)
Dimensions:	6.38"W [16.2 cm] x 2.36"D [6 cm] x 3.54"H [9 cm]
Unit weight:	2 lb [.9 kg]
Shipping weight:	2.35 lb [1 kg]



Product update

New USB-C Power Module version available. See details at:

www.spectrumfurniture.com

See p.5 for more information

Cove™ Power Module with Easy Power Connection Kit



99047 - for 48"W Table
99048 - for 60"W Table
99049 - for 72"W Table

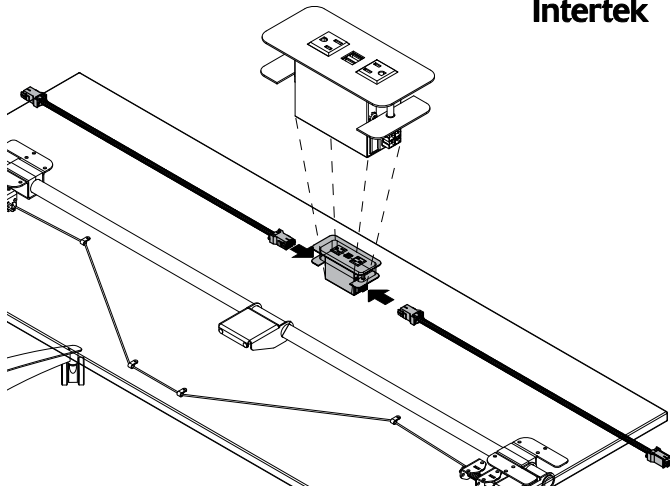

- Each power connection kit accommodates one table
- Two AC power receptacles
- Two USB charge ports (not data-compatible)
- Worksurface requires 5.25"W x 2"D worksurface cutout
- Flexible metal conduit is secured to worksurface underside
- Starter (order separately) connects to standard 3-prong wall outlet
- Thumbscrew clamps
- Available in Black or Silver
- ETL listed

Cutout required:	5.25"W [13.3 cm] x 2"D [5.1 cm]
Power cord:	15A
Power receptacles:	12A, 120 VAC spill-resistant (2 receptacles)
USB charging ports:	2.1A (10.5W) (2 USB charging ports)
Power module dimensions:	6"W [15.2 cm] x 2.5"D [6.35 cm] x 3.18"H [8.1 cm]

See p.6 for more information



99050 - Starter Kit (Sold Separately)

(One required per row)
 72" [183 cm], 20-15A

To wall outlet

Note: The starter cable can be routed through the leg to the floor.

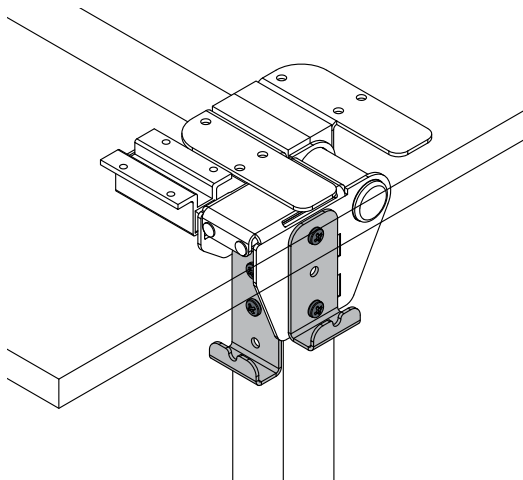

Backpack Hanger Bracket - 99061

- (One) bracket included
- Available in all metal colors
- 12 ga steel
- Each hanger bracket installs with (2) included screws
- 2-positions available
- Each Flex Active Flip Table supports up to 4 brackets

See spectrumfurniture.com for the latest accessories and detailed warranty information.

Warranty

We will make it right for you!

Thanks for choosing Spectrum! Spectrum is committed to provide complete customer satisfaction. Each of our products is manufactured from the best materials available and each product is stringently monitored throughout the production process through our P.A.C.E. program (Product Assurance to meet Customer Expectations).

We expressly warrant that Spectrum products will be of good quality and workmanship and free from defect for the period set out in the warranty from the date of delivery.

For a listing of all product specific warranty terms please visit our website at:

<https://www.spectrumfurniture.com/en/resources/purchasing-terms-warranty>

1-800-235-1262

Toll-free HELPLINE

spectrum@spectrumfurniture.com