

Technical Specifications

55411

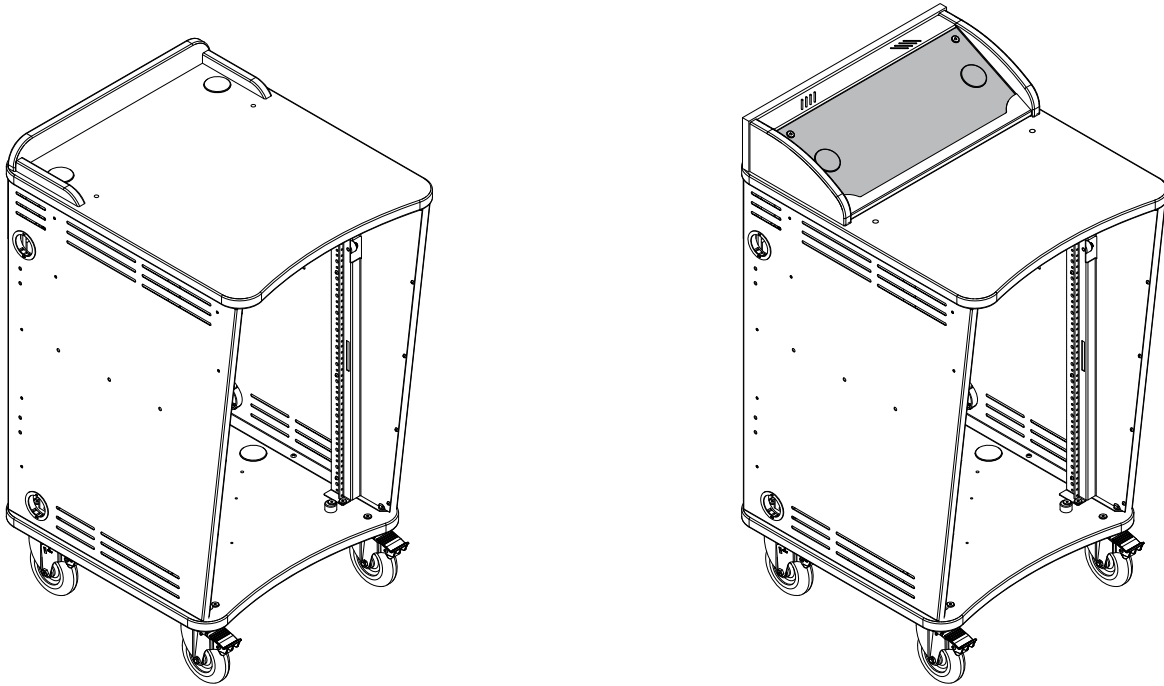

Use the Inspiration Plus Lectern where a small-footprint lectern with rack rail for equipment storage is required. The Inspiration Plus Lectern is available in two heights; 36 inch and 42 inch. The 36-inch lectern has 15 rack units available and the 42-inch lectern has 19 rack units. On the audience side is a lockable door that can have an optional custom-cut logo. An optional locking presenter side door is available. The lectern can have either a toe kick or five-inch balloon casters installed for stationary or mobile use. The worksurface is 24-inches wide and 28-inches deep. The worksurface has a surround, two covered wiring holes, and two mounting holes for optional monitor arm installation on the left or right. An optional Overbridge Control Console can be added to the worksurface for additional control access. Up to two optional flip-up shelves can be added to increase the worksurface size. An optional keyboard tray is available. Other options available include a side table that can be mounted to the left or the right side of the lectern, audience side rack rail to double the rack units, and rack-mount accessories (shelves, drawers, cooling fans, and others).

Features and Benefits

- Available in 36" or 42" heights for optimal viewing level
- Durable powder coated steel chassis provides a long-lasting finish
- Scratch and impact-resistant high-pressure laminate top provides a durable, useful worksurface for instructors
- Four inboard 5" locking balloon wheel plate casters with metal construction and non-marring rubber provide the easiest-rolling, and quietest transport in the industry (rated for 325 lb each) (BW / SR)
- Toe kick (TK) version available when mobility is not necessary or desired
- Standard locking audience-side door provides easy-access to equipment (can be flipped to be hinged from the left or right)
- Plain, surround, or overbridge worksurfaces available
- Blank overbridge console version allows custom cutouts and installation of presentation controllers
- Two 2" cable grommets (left and right) on the worksurface or overbridge provide cable access
- Instructor-side rack-rail equipment mounting (42"H - 19RU, 36"H - 15RU)
- Locking audience side door provides security and easy-access
- Ventilated side panels help keep equipment cool
- Cable grommets keep wires and cords organized
- Can be used in a seated or standing position
- Worksurface and base panel vinyl edging protects walls and furniture
- Lectern ships fully-assembled for quick, simple integration and deployment
- Optional keyboard tray can be installed under worksurface
- Optional flip-up document camera / task shelf provides a convenient additional worksurface
- Optional locking instructor-side door provides security
- Optional 15RU rear rack rail provides additional rack units if necessary
- Optional ADA-compliant side table provides additional presentation space
- Warranted to be free of all defects in materials and workmanship for 10 years
- Designed and assembled in Chippewa Falls, WI, USA

Color Options

Available in Spectrum Expressions colors.
See spectrumfurniture.com for complete color information.

Ordering Instructions

Spectrum has designed this product to receive the useful options shown here.
To ensure your options are ordered correctly please call 1-800-235-1262.

Construction

- The worksurface, base panel, and surround is constructed from 1" thick composite board with .030" high-pressure laminate on one face, and a balancing phenolic backer on the opposing face
- Metal components consist of 16 and 20-gauge steel
- Worksurface edges are covered with 3mm vinyl
- All metal components are finished with a scratch-resistant powder coat epoxy
- Each Inspiration Plus Lectern is factory-assembled with casters or toe kick, packaged, and shipped on its own skid

Specifications

| | | |
|-------------------------------|---|---|
| Total internal area (nominal) | 21.5"W [54.6 cm] x 18.75"D [47.6 cm] x 28"H [71.1 cm] (36"H) 34"H [86.4 cm] (42"H) | |
| Standard rack rail | 36"H 15RU | 42"H 19RU |
| 5" Balloon Wheels | Weight capacity 300 lb [136 kg] each | |
| Certifications / Compliance | • Meets or exceeds applicable ANSI-BIFMA test standards | |
| Unit weight (nominal) | 36"H 89 lb [40.4 kg] 99 lb [45 kg] with OCC | 42"H 95 lb [43.1 kg] 105 lb [47.7 kg] with OCC |
| Shipping weight (nominal) | 36"H 124 lb [56.3 kg] 134 lb [60.8kg] with OCC | 42"H 130 lb [59 kg] 140 lb [63.6 kg] with OCC |

Specifications subject to change without notice

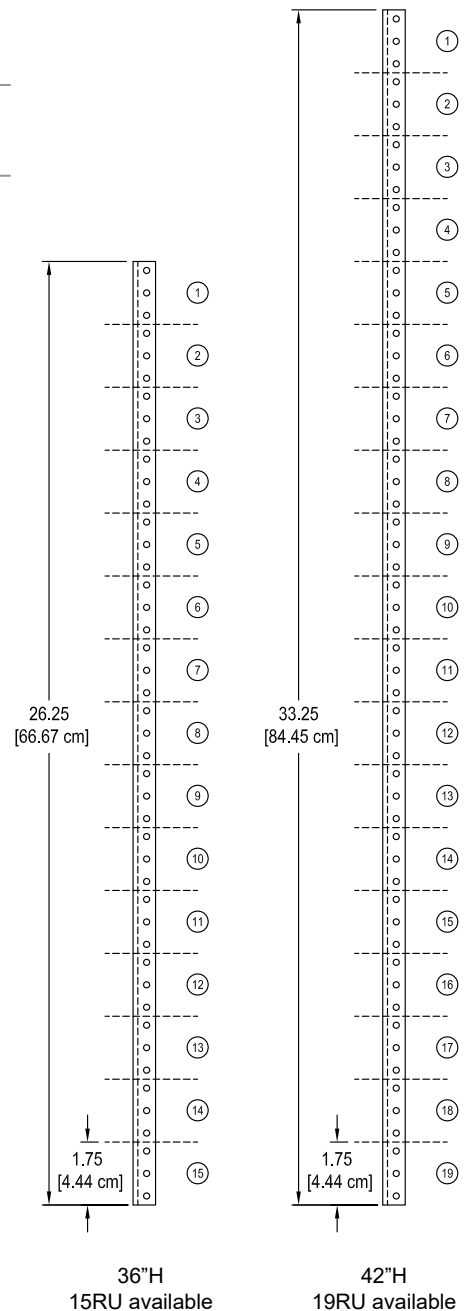
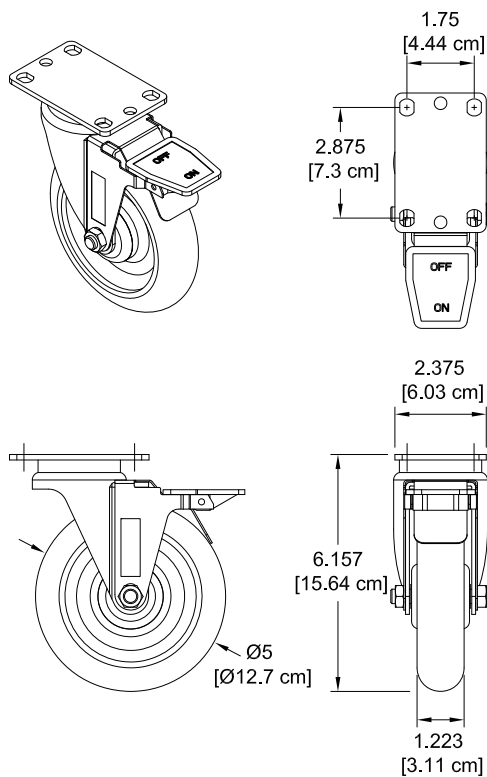

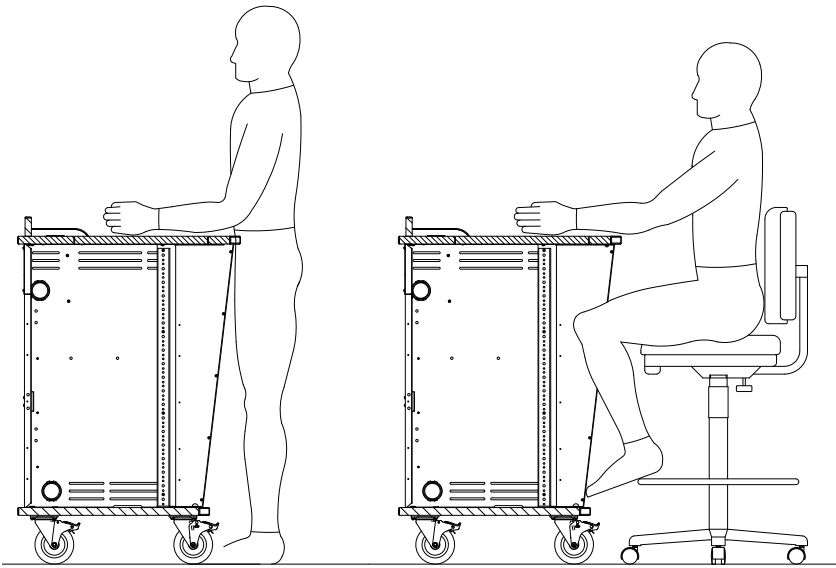

Standing position
(42" Inspiration Plus shown)

Seated position
(42" Inspiration Plus shown)

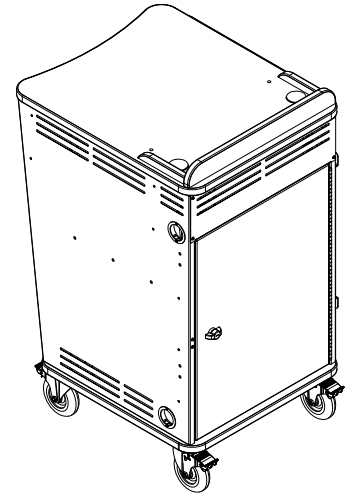

Audience-side view

Worksurface Height

ORDER CODE 36 = 36"H

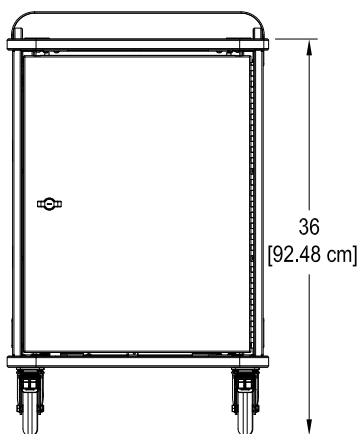

ORDER CODE 42 = 42"H

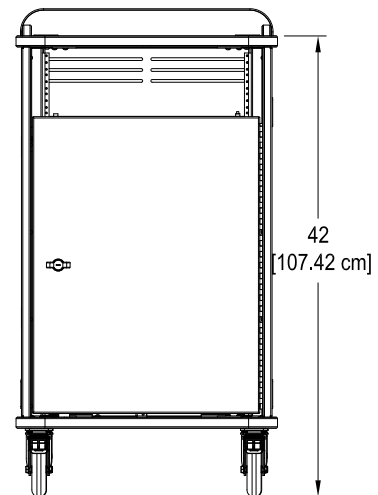

Note: Shown with optional instructor-side door. If the door option is used on a 36"H Inspiration Plus Lectern, a keyboard tray cannot be used.

Note: Shown with optional instructor-side door. If the door option is used on a 42"H unit without an installed keyboard tray, a 4RU rack-mount blank should be installed above the door to maintain security.

Worksurface Style

| | |
|------------------------|--|
| ORDER CODE P1 = | <ul style="list-style-type: none"> • Plain |
| ORDER CODE P2 = | <ul style="list-style-type: none"> • Plain • Custom cutout(s) <i>(see p.5 for details)</i> |

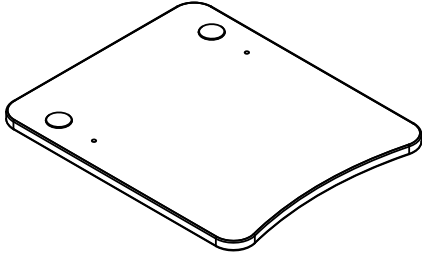

| | |
|------------------------|---|
| ORDER CODE S1 = | <ul style="list-style-type: none"> • Surround |
| ORDER CODE S2 = | <ul style="list-style-type: none"> • Surround • Custom cutout(s) <i>(see p.5 for details)</i> |

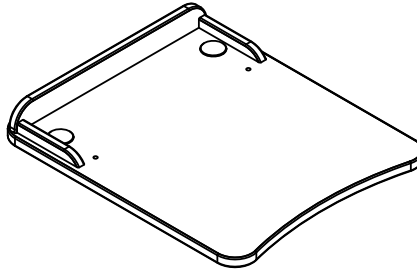

| | |
|------------------------|---|
| ORDER CODE B1 = | <ul style="list-style-type: none"> • Overbridge |
| ORDER CODE B2 = | <ul style="list-style-type: none"> • Overbridge • Custom cutout(s) in insert panel <i>(see p.5 for details)</i> |

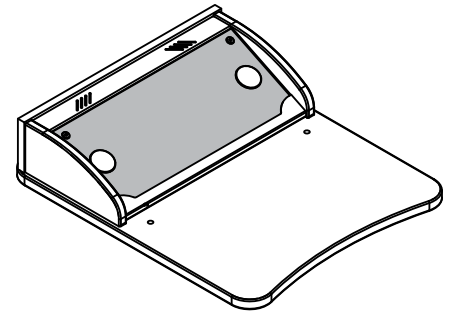

| | |
|------------------------|---|
| ORDER CODE P3 = | <ul style="list-style-type: none"> • Plain • Power Module |
|------------------------|---|

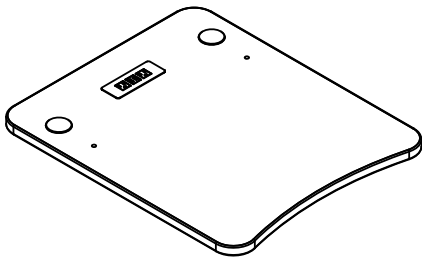

| | |
|------------------------|--|
| ORDER CODE S4 = | <ul style="list-style-type: none"> • Surround • Power Module |
|------------------------|--|

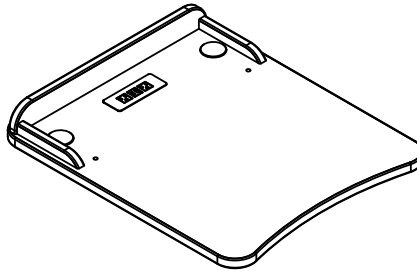

| | |
|------------------------|--|
| ORDER CODE P5 = | <ul style="list-style-type: none"> • Plain • EM Wireless |
|------------------------|--|

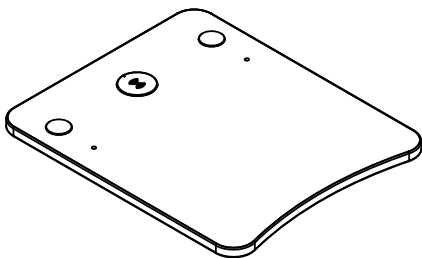

| | |
|------------------------|---|
| ORDER CODE S6 = | <ul style="list-style-type: none"> • Surround • EM Wireless |
|------------------------|---|

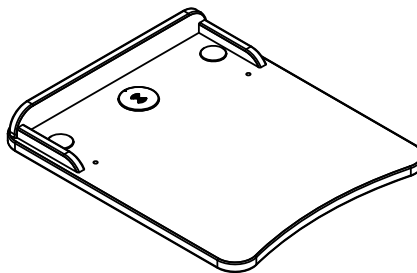

| | |
|------------------------|--|
| ORDER CODE B3 = | <ul style="list-style-type: none"> • Overbridge • EM Wireless |
| ORDER CODE B4 = | <ul style="list-style-type: none"> • Overbridge • EM Wireless • Custom cutout(s) in insert panel <i>(see p.5 for details)</i> |

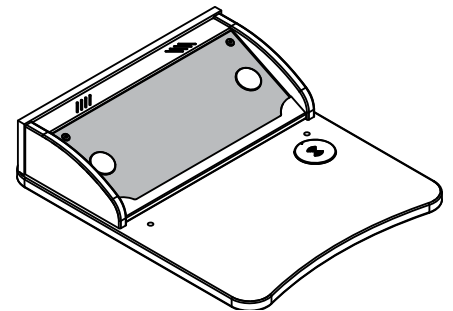

| | |
|------------------------|--|
| ORDER CODE P4 = | <ul style="list-style-type: none"> • Plain • Power Module • EM Wireless |
|------------------------|--|

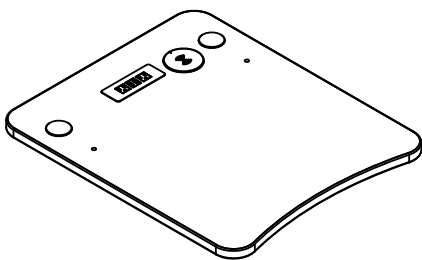

| | |
|------------------------|---|
| ORDER CODE S5 = | <ul style="list-style-type: none"> • Surround • Power Module • EM Wireless |
|------------------------|---|

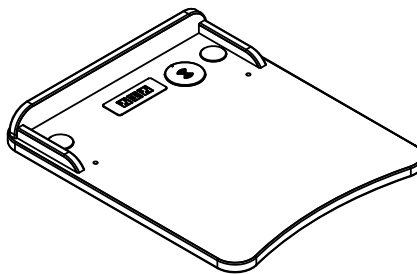

Note: All worksurface styles include:

- (2) 2" grommets and covers
- (2) .375" holes (one left, one right) for monitor arm mounting. Plugs also included.

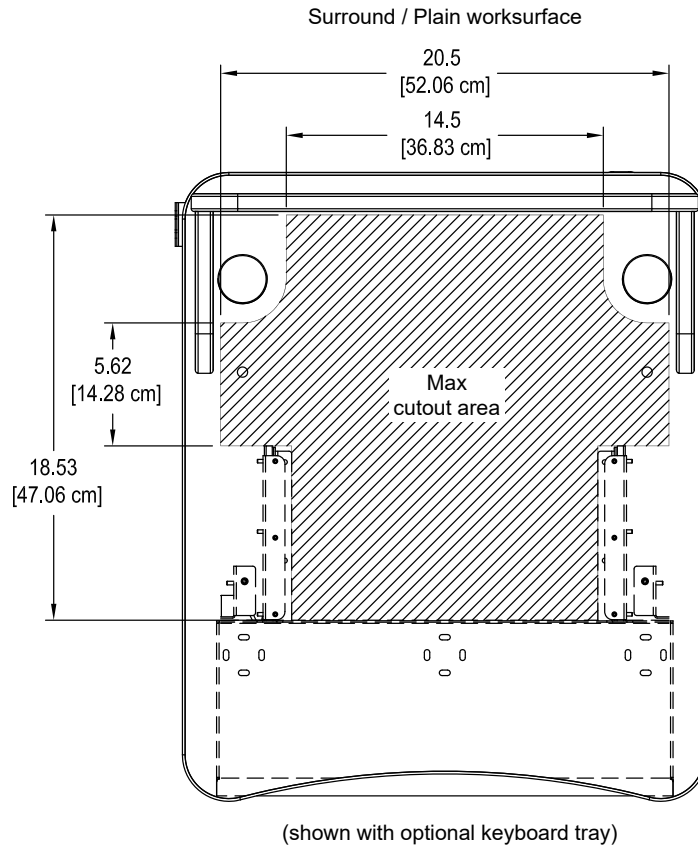

- Contact Spectrum to specify cutout size(s) and location(s)

Overbridge insert panel blank
(flat view)

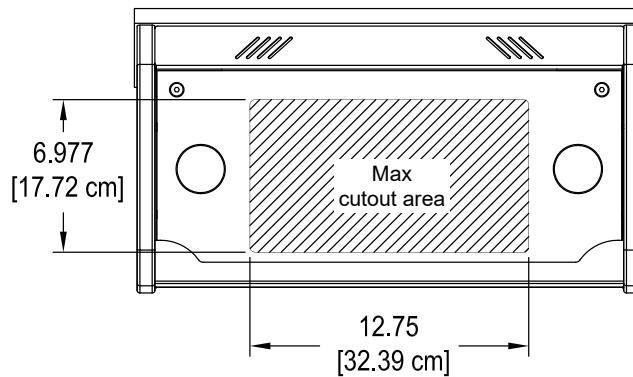

- Contact Spectrum to specify cutout size(s) and location(s)
- Panel color: black

Cutouts in blank overbridge panels can be made by the customer after the lectern has been purchased, but are only recommended within the cutout areas shown.

Spectrum Industries, Inc. manufactures furniture that supports a wide variety of power and communication devices from a variety of manufacturers. This lectern is compatible with many Extron, Crestron, Alinex, AMX, and other devices. Spectrum does not resell these products; *please consult your electronic supplier* for the equipment that best suits your needs. Size specifications from the manufacturer can be used to verify the fit.



Note: Some controllers and devices require additional space around the cutout for clamping under the worksurface. Please double check your device specifications to ensure adequate space around the cutout.

Spectrum can provide cutouts exactly matching any commercially available data and electrical power outlet, but are only recommended within the maximum cutout areas shown. Cutouts should be reviewed by Spectrum to ensure clearance of brackets, keyboard tray slides, or other objects under the worksurface. Please contact Spectrum (with preferred accessories & cutouts) for assistance with worksurface cutout placement.

***When ordering a lectern with cutouts, specify complete details of the device(s) (brand, model number, cutout size, quantity, etc.) to the Spectrum sales rep when ordering.**

| | |
|-----------------------|------|
| ORDER CODE 0 = | None |
| ORDER CODE 1 = | Yes |

15RU Rear Rack Rail Kit

- Set of 2 rails with mounting brackets

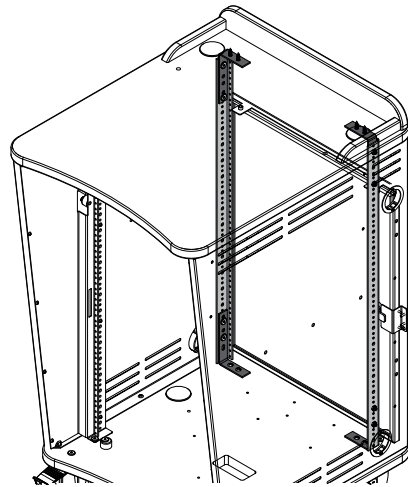

Flip-Up Shelf

| | |
|-----------------------|---------------------------------------|
| ORDER CODE 0 = | None |
| ORDER CODE C = | 1 shelf, Matching laminate |
| ORDER CODE D = | 2 shelves, Matching laminate |
| ORDER CODE E = | 1 shelf, Chalk white dry erase (WD) |
| ORDER CODE F = | 2 shelves, Chalk white dry erase (WD) |

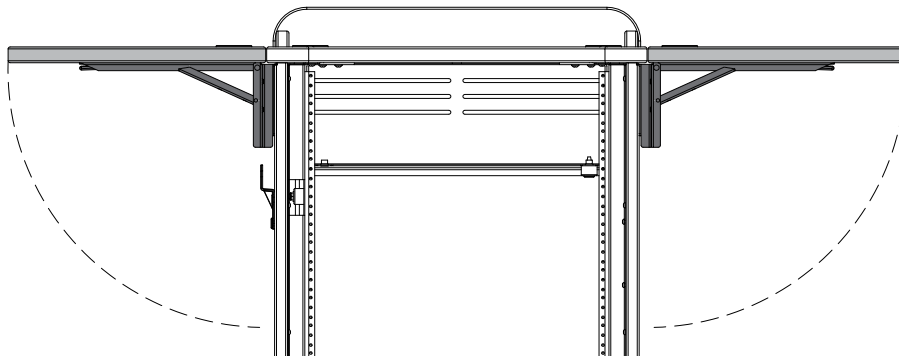

- Shelf hinges lock into place in the upright position
- Includes 2" grommet
- Mounts on left or right (max 2 per unit)
- Available in White Chalk Dry Erase laminate. Flip-up shelves configured with white laminate will have the same edgeband color as the worksurface and base panel.
- Customer-installed

Weight capacity: 35 lb [15.9 kg]
 Dimensions: 16"W [40.6 cm] x 19.375"D [49.2 cm]

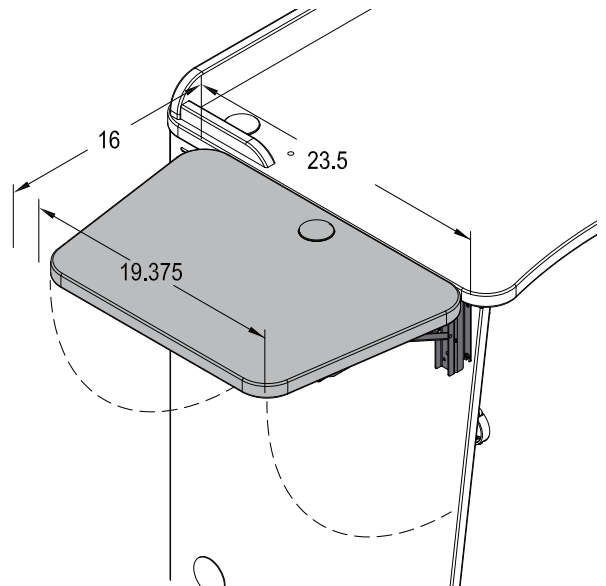

Note: Power and communication wiring for document cameras, laptop computers, and/or projectors placed on the flip-up shelf should be routed on top of the audience-side of the shelf. Use of the shelf grommet hole for wiring will result in pinching of the cords when the shelf is folded.

ORDER CODE 5B = Four 5" Swivel Balloon Wheels

BW
5" Balloon Wheels (four swivel)
Provides more maneuverability in tight spaces, but less control when mobile

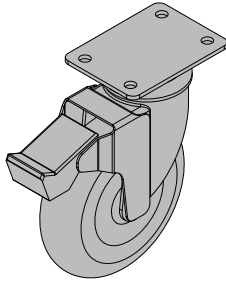

ORDER CODE TK = Toe Kick

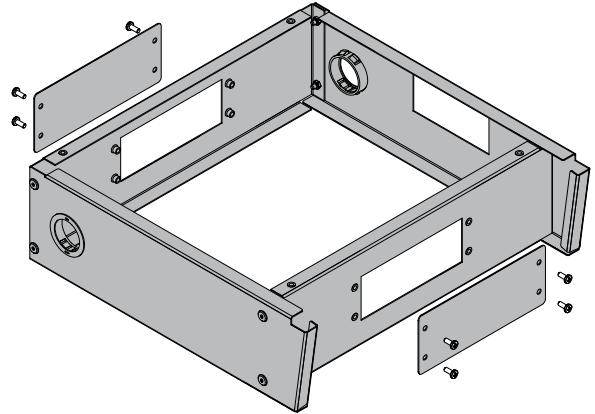

Audience-Side Door with Custom Logo

| | |
|-----------------------|--|
| ORDER CODE 0 = | Door only |
| ORDER CODE 1 = | Audience-side door with custom logo (with <u>matching laminate</u> backer) |
| ORDER CODE 3 = | Audience-side door with custom logo (with <u>white laminate</u> backer) |
| ORDER CODE 4 = | Audience-side door with custom logo (with <u>black laminate</u> backer) |
| ORDER CODE 5 = | Audience-side door with custom logo (with <u>printed</u> backer) |

Audience-Side Door with Custom Logo

- Available for 36"H, or 42"H Inspiration lecterns
- With single bolt lock
- To get door customized-contact Spectrum for details
- New logos require a first time logo charge

Dimensions: 20.875"W [53 cm] x 27.25"H [69.2 cm]
 Available logo area: 18"W [45.7 cm] x 11"H [27.9 cm]

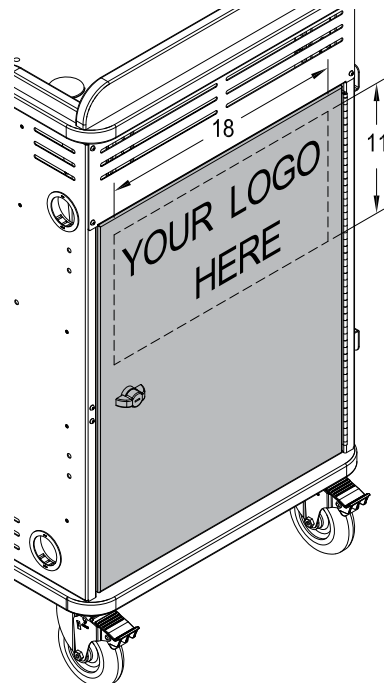

ORDER CODE 1 = Power Module - Black

ORDER CODE 2 = Power Module - Silver

ORDER CODE 6 = Power Module - White

ORDER CODE 3 = Power Module - Black & EM Wireless Charging Pad

ORDER CODE 4 = Power Module - Silver & EM Wireless Charging Pad

ORDER CODE 7 = Power Module - White & EM Wireless Charging Pad

- Factory-installed
- (2) AC receptacles (tamper-resistant)
- (2) USB ports rated at 2.1A each (10.5 watts)
- Aluminum housing and flange
- 10' 14AWG *3C power cord
- When specified, the Power Module is centered on the audience-side edge of the worksurface
- Worksurface cutout size: 5.65"W x 1.65"D
- ETL-certified

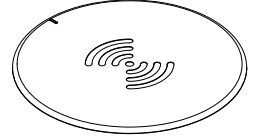
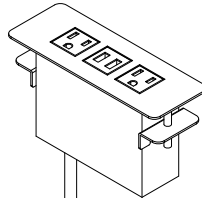
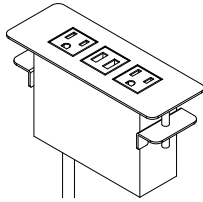

ORDER CODE 5 = EM Wireless Charging Pad

- Uses electromagnetic technology to charge Qi V1.2 compliant IC devices ("Qi" enabled)
- LED to confirm pairing / charging
- Security tab prevents theft
- Includes 3" round cutout
- UL-certified

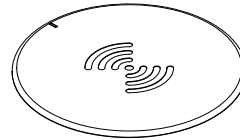

| | |
|----------------|------|
| ORDER CODE 0 = | None |
| ORDER CODE 1 = | Yes |

Keyboard Tray

- Wiring slots
- 16ga steel

Dimensions: 20.625"W [52.4 cm] x 7"D [17.8 cm] x 2"H [5 cm]
(height available under worksurface)

Slides: 14" [35.6 cm] extension

Weight capacity: 25 lb [11.4 kg]

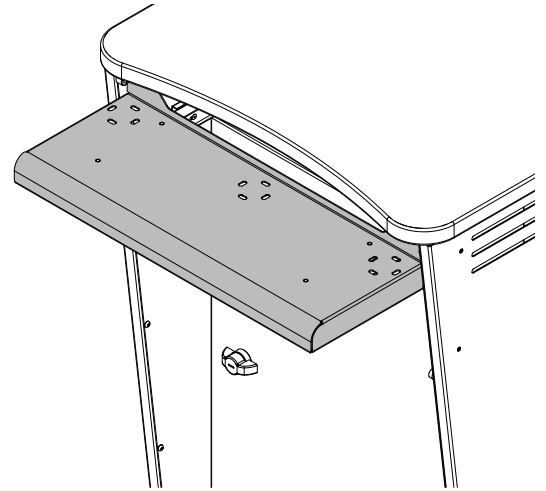

Note: The keyboard tray occupies 3RU at top of rack rail. Shown with optional instructor-side door. If the door option is used on a 36"H Inspiration Plus Lectern, a keyboard tray cannot be used.

Instructor-side door

ORDER CODE 1 = Yes

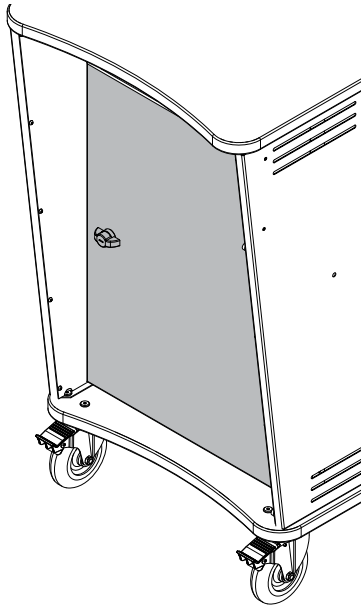

ORDER CODE 0 = None

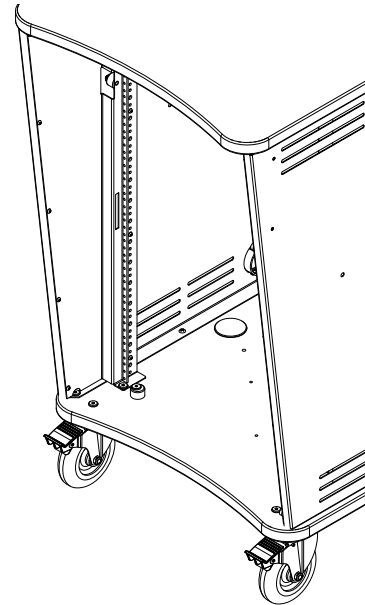

Instructor-Side Door

- Available for 36"H, or 42"H lecterns
- With single bolt lock
- Can be installed to be hinged on left or right
- 20ga welded steel

Dimensions: 20.875"W [53 cm] x 27.25"H [69.2 cm]

Note: When the door option is used on a 36"H Inspiration Plus Lectern, a keyboard tray cannot be used. If the door option is used on a 42"H unit without an installed keyboard tray, a 4RU rack-mount blank is recommended above the door to maintain security.

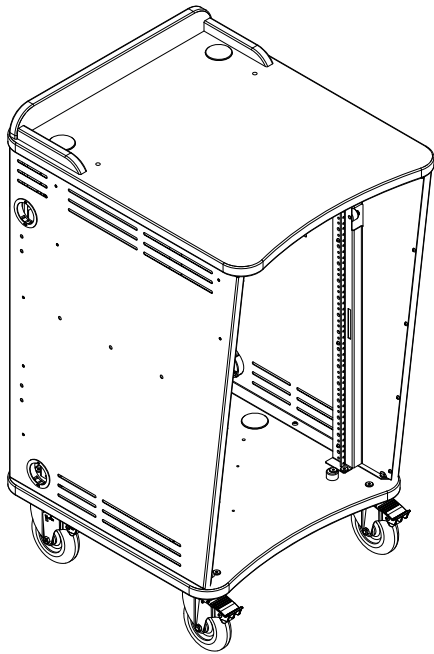

42" Inspiration Plus Lectern
with 5" Balloon Wheels

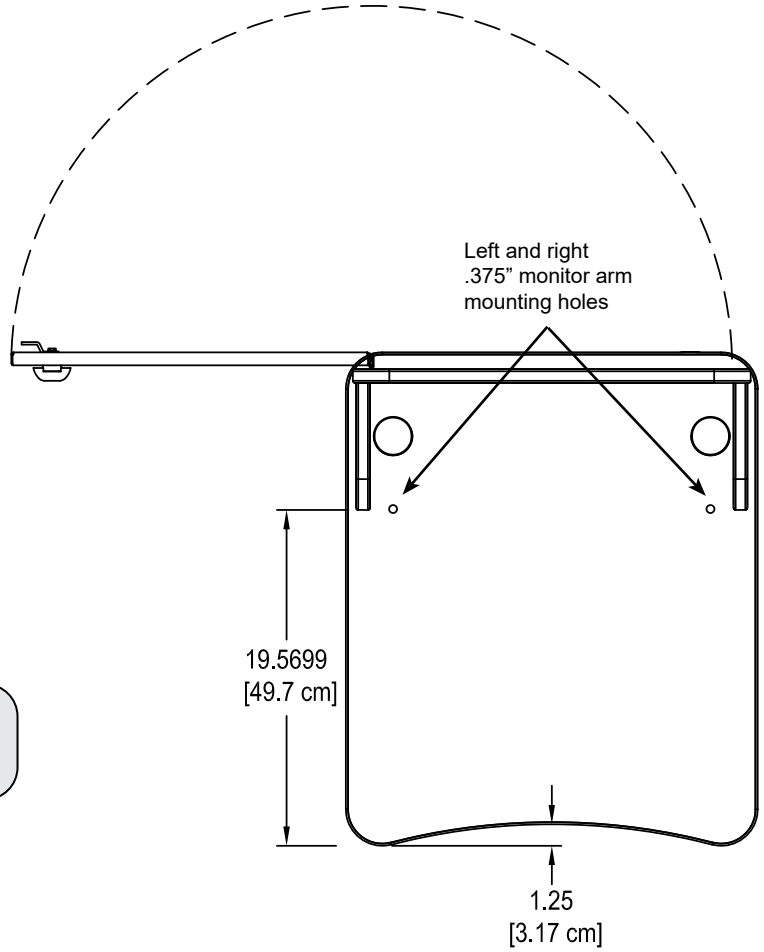

Note: Modified worksurface cutouts should be reviewed by Spectrum to ensure clearance of brackets, keyboard slides, or other objects under the worksurface.

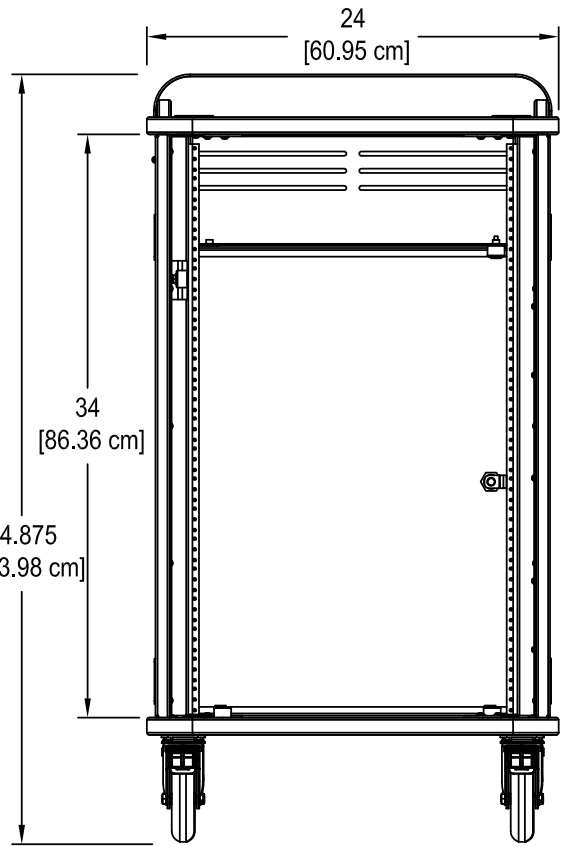
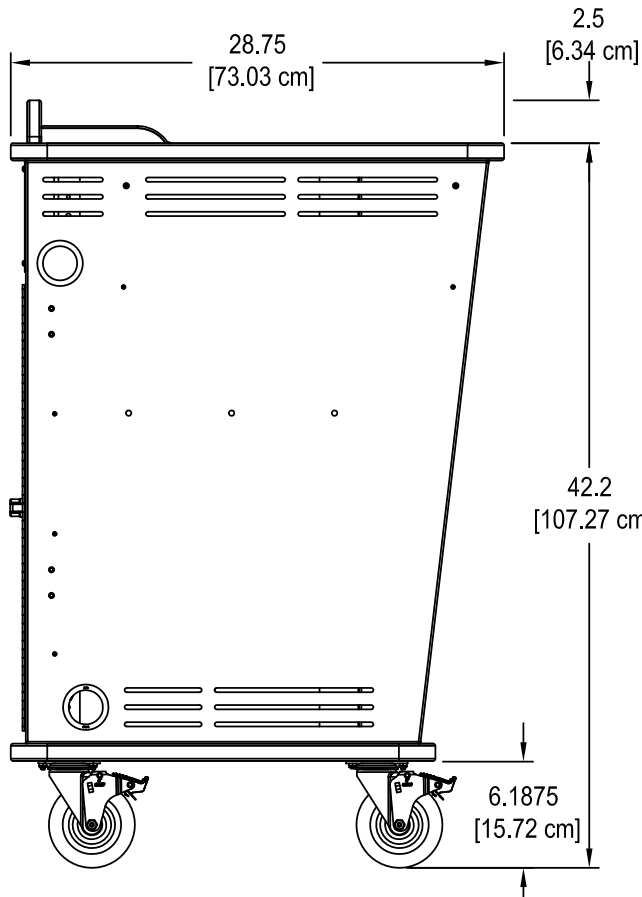

42" Inspiration Plus Lectern with Toekick

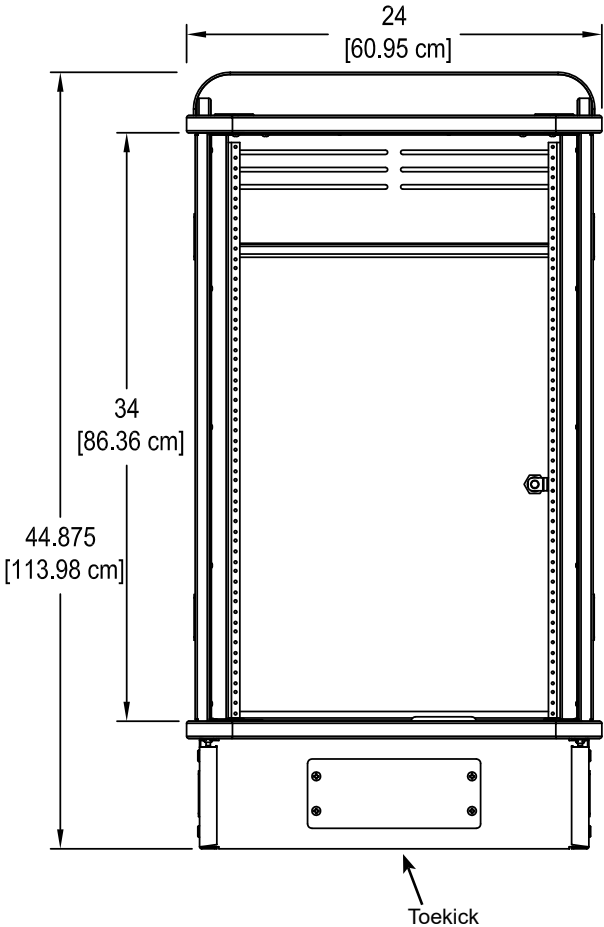
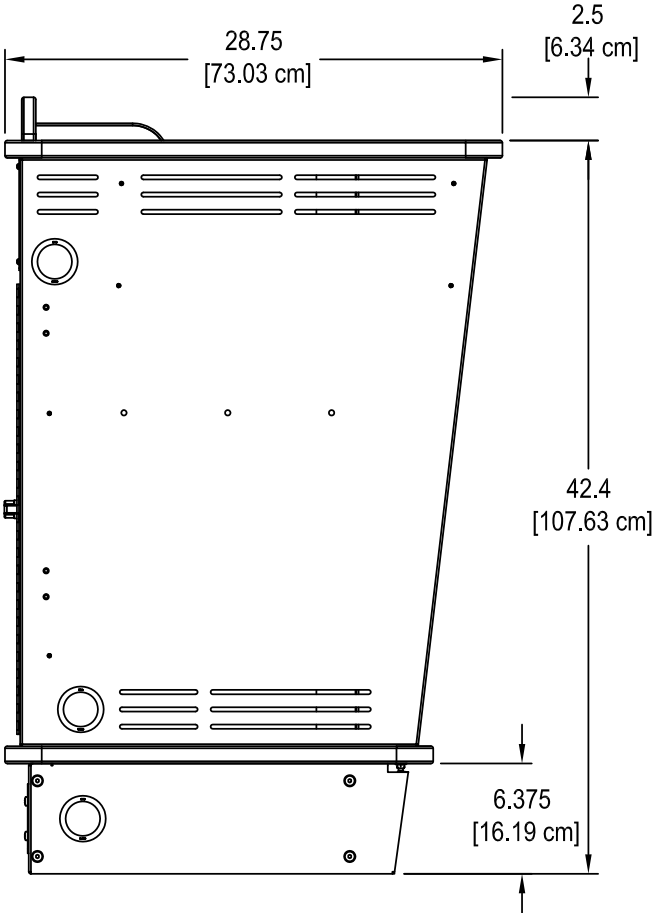

36" Inspiration Plus Lectern with 5" Balloon Wheels

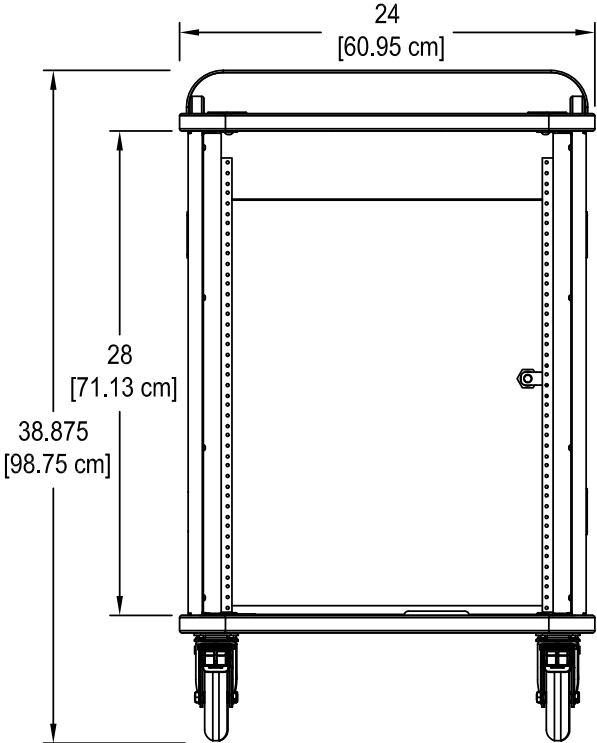
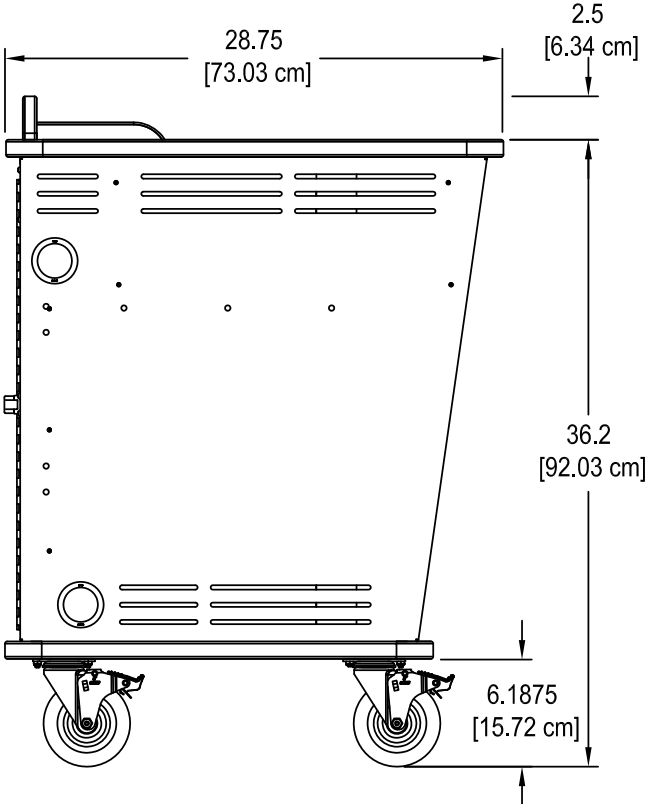

42" Inspiration Plus Lectern section view

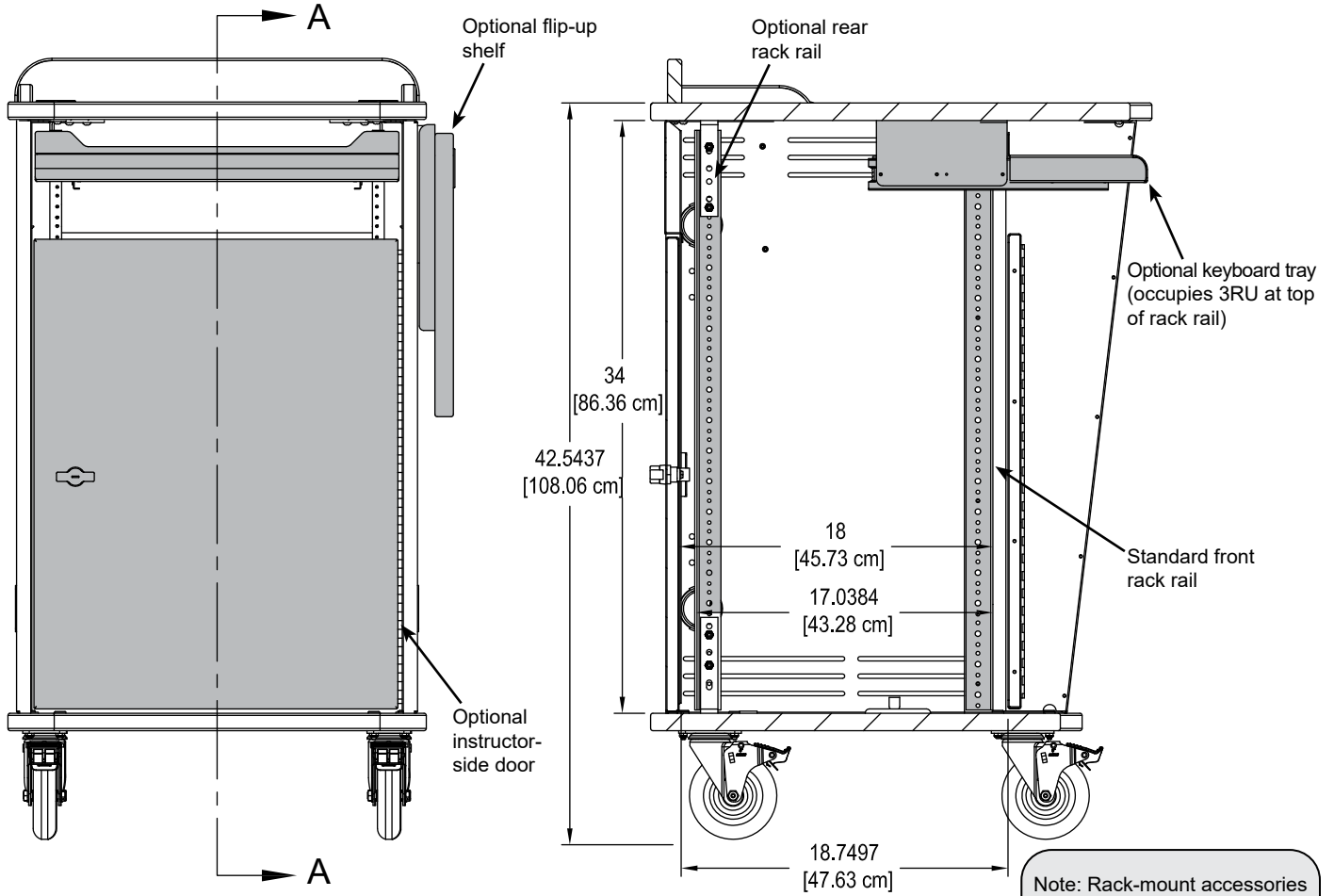

Note: Rack-mount accessories with a depth greater than 18"D will not fit inside the lectern. Check the dimensions of all equipment before installation.

36" Inspiration Plus Lectern section view

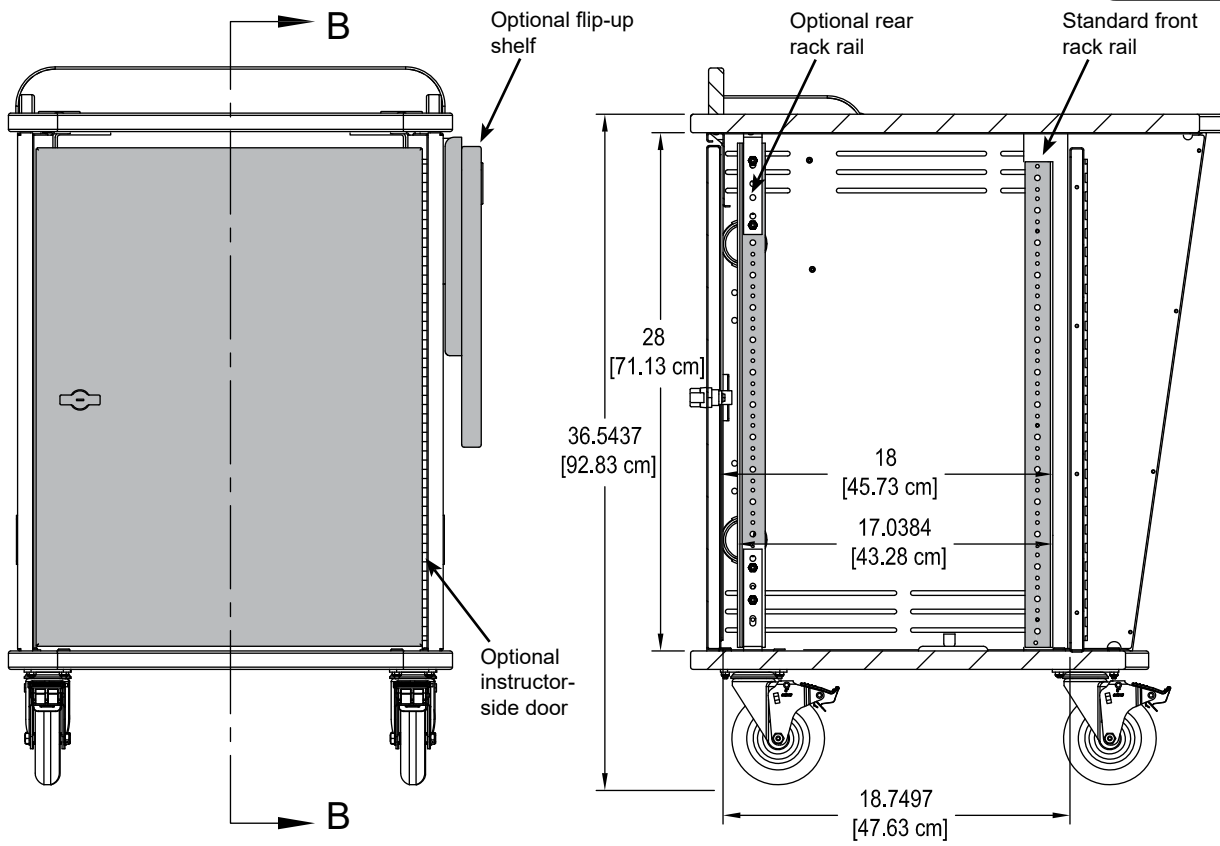

36" Inspiration Plus Lectern
with Overbridge Control Console
and 5" Balloon Wheels

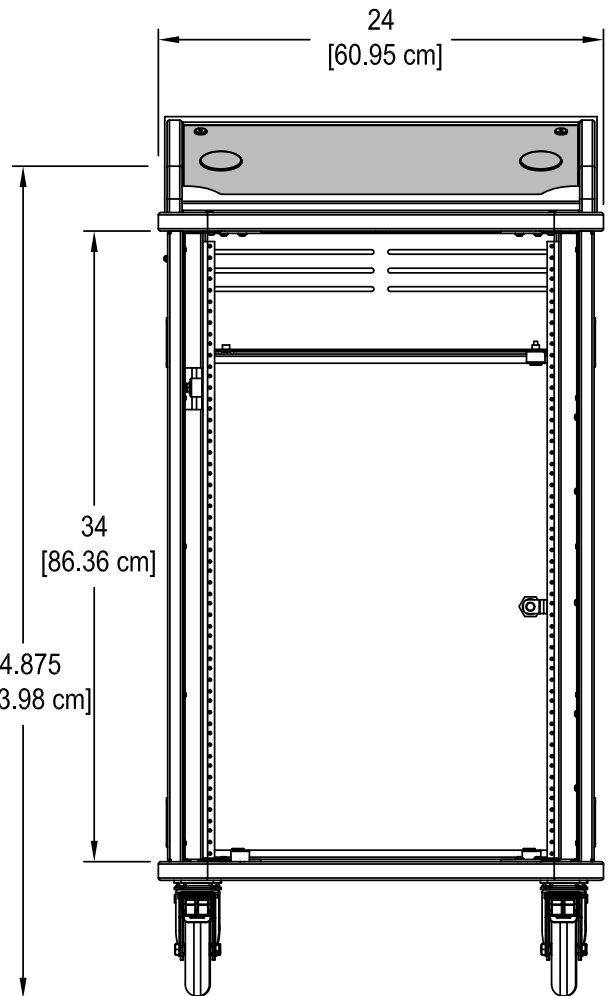
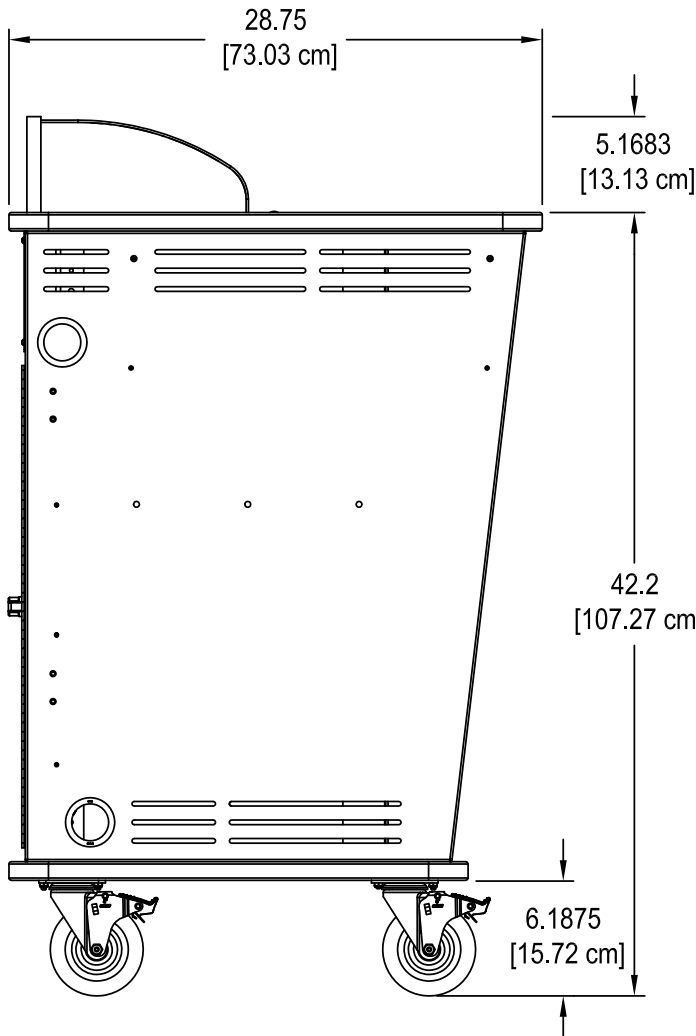
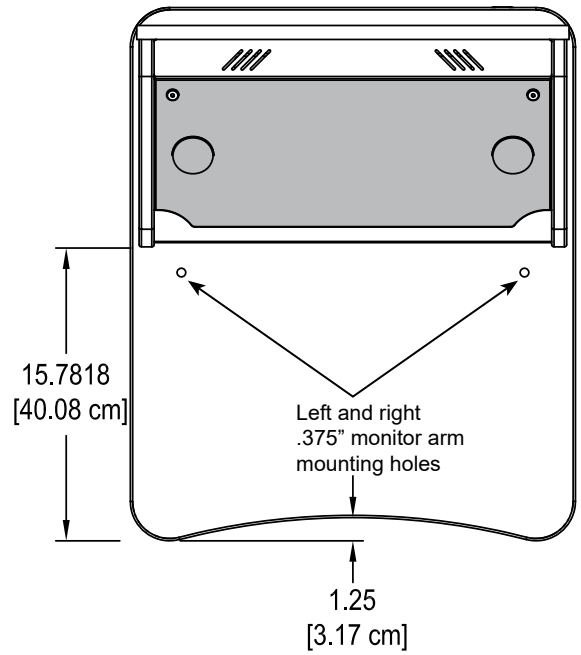
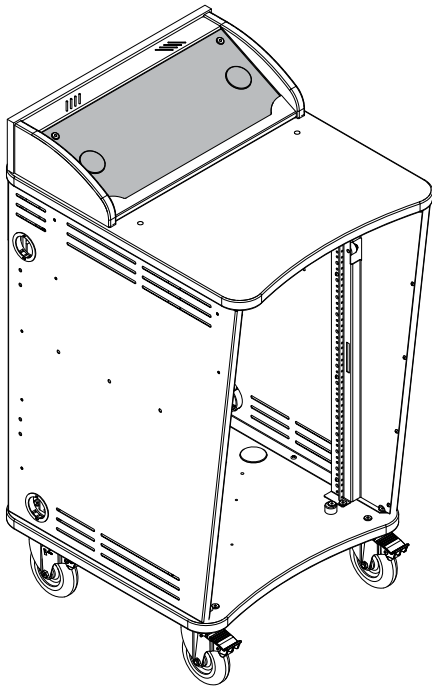

Inspiration Plus Overbridge Insert Panel Blank
(flat view)

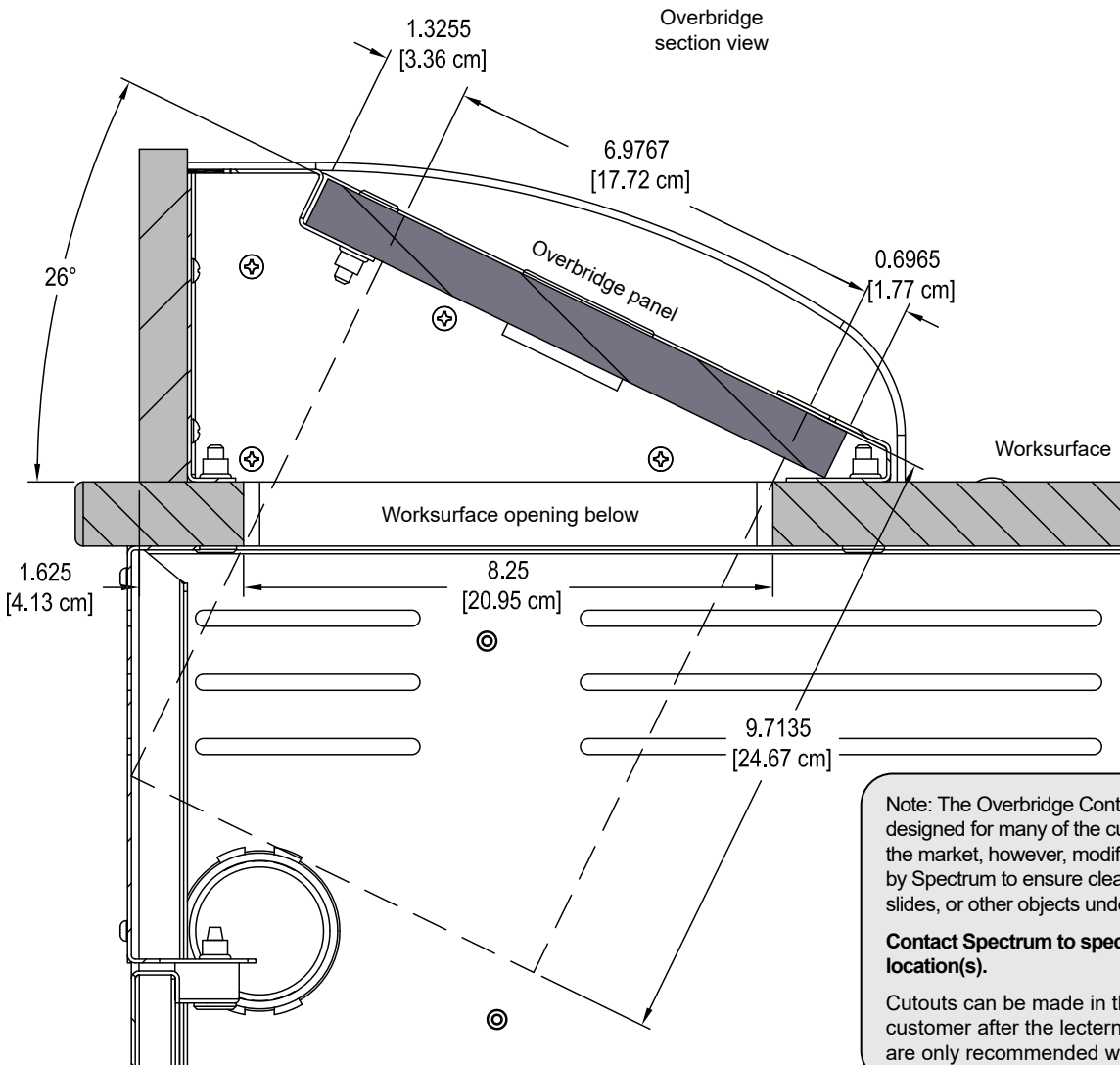
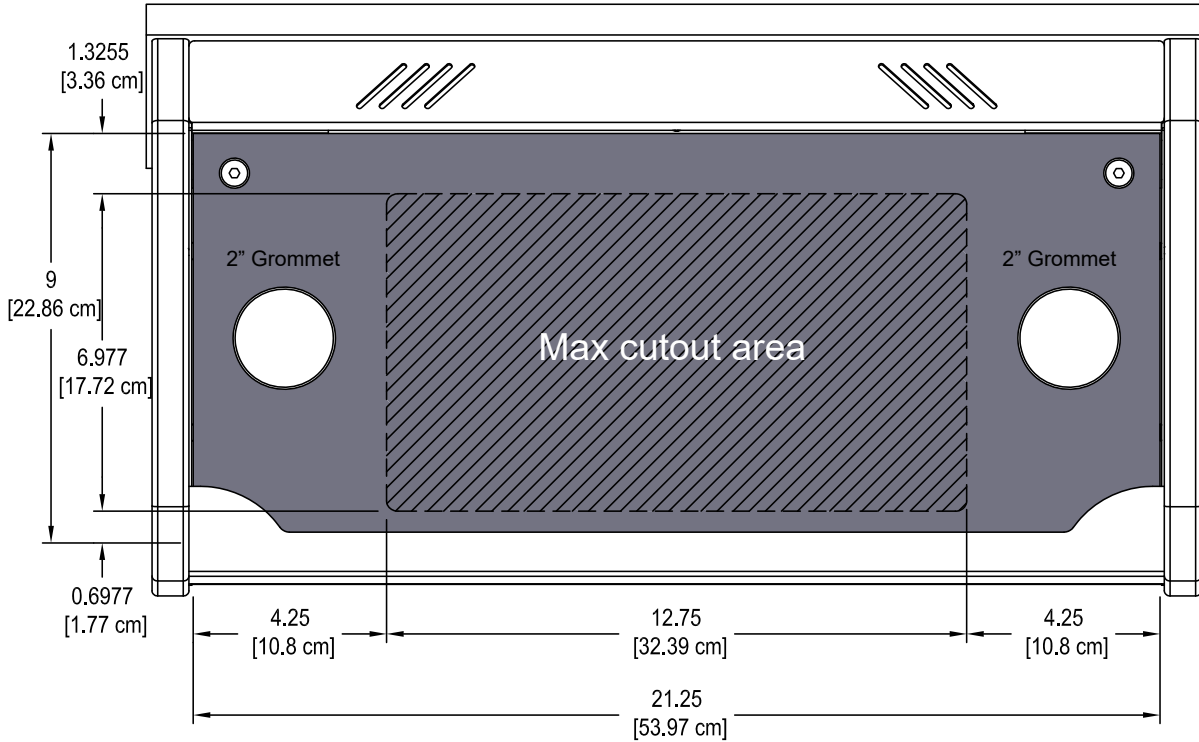

Note: The Overbridge Control Console™ has been designed for many of the currently available controllers on the market, however, modified cutouts should be reviewed by Spectrum to ensure clearance of brackets, keyboard slides, or other objects under the worksurface.

Contact Spectrum to specify cutout size(s) and location(s).

Cutouts can be made in the blank insert panel by the customer after the lectern has been purchased, but are only recommended within the cutout area shown.

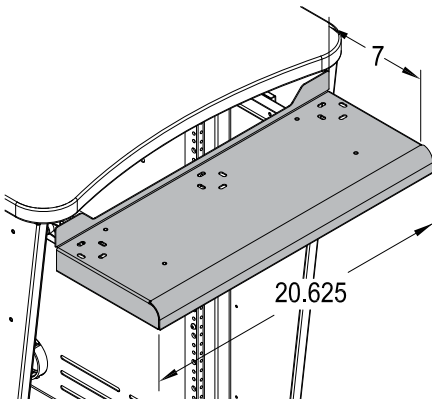

Keyboard Tray - 95538

- Wiring slots
- 16ga steel

Dimensions: 20.625"W [52.4 cm] x 7"D [17.8 cm] x 2"H [5 cm] (height available under worksurface)

Slides: 14" [35.6 cm] extension

Weight capacity: 25 lb [11.4 kg] weight capacity

Shipping weight: N/A

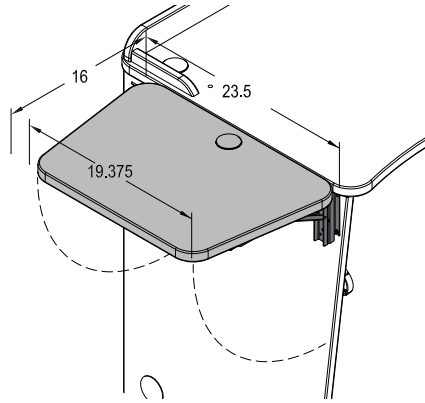

Flip-Up Shelf - 55536

- Shelf hinges lock into place in the upright position
- Includes 2" grommet
- Available in White Chalk Dry Erase laminate
- Mounts on left or right (max 2 per unit)

Weight capacity: 35 lb [15.9 kg]

Dimensions: 16"W [40.6 cm] x

19.375"D [49.2 cm]

Shipping weight: N/A

Instructor-Side Door - 55405

- Available for 36"H, or 42"H lecterns
- With single bolt lock
- Can be installed to be hinged on left or right
- 20ga welded steel

Dimensions: 20.875"W [53 cm] x 27.25"H [69.2 cm]

Shipping weight: N/A

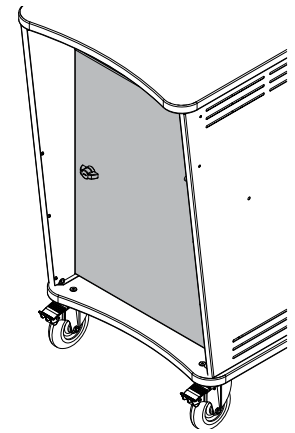

Note: When fully-retracted, the keyboard tray occupies 3RU of rack space at the top of the lectern. When the door option is used on a 36"H Inspiration Plus Lectern, a keyboard tray cannot be used.

Note: Power and communication wiring for document cameras, laptop computers, and/or projectors placed on the flip-up shelf should be routed on top of the audience-side of the shelf. Use of the shelf grommet for wiring will result in pinching of the cords when the shelf is folded.

Note: When the door option is used on a 36"H Inspiration Plus Lectern, a keyboard tray cannot be used. If the door option is used on a 42"H unit without an installed keyboard tray, a 4RU rack-mount blank is recommended above the door to maintain security.

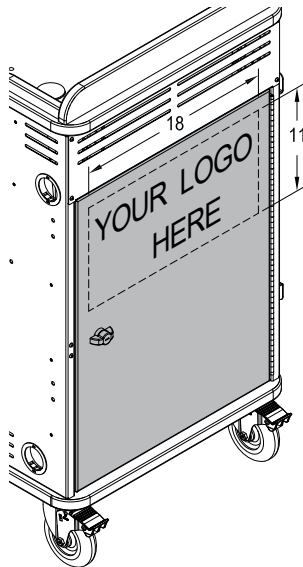

Audience-Side Door with Custom Logo - 55414

- Available for 36"H, or 42"H Inspiration lecterns
- With single bolt lock
- Available with black, white, or matching laminate backer
- To get door customized-contact Spectrum for details
- New logos require a first time logo charge

Dimensions: 20.875"W [53 cm] x 27.25"H [69.2 cm]

Available logo area: 18"W [45.7 cm] x 11"H [27.9 cm]

Shipping weight: 14.1 [6.4 kg]

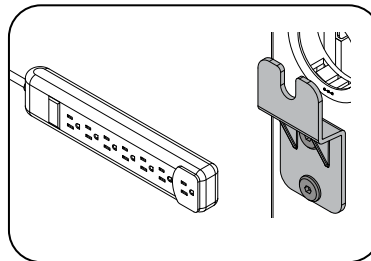

Power Strip + (2) Cord Wraps - 55404

- 7-outlet surge-protected

Power Strip: 12"W [30.5 cm] x 2"D [5.1 cm] x 1.3125"H [3.3 cm]

Power Cord: 24" [457.2 cm] cord

Shipping weight: 2.4 lb [1.1 kg]

Rear Rack Rail Kit

55408 - 36"H [91.4 cm] (15RU)
55407 - 42"H [106.7 cm] (19RU)

- Set of 2 rails with mounting brackets

Shipping weight: 4.9 lb [2.2 kg] - 55408
 5.9 lb [2.7 kg] - 55407

Note: 42" Inspiration Plus Lecterns have an audience-side structural panel that limits accessible rear rack spacing to 15RU.

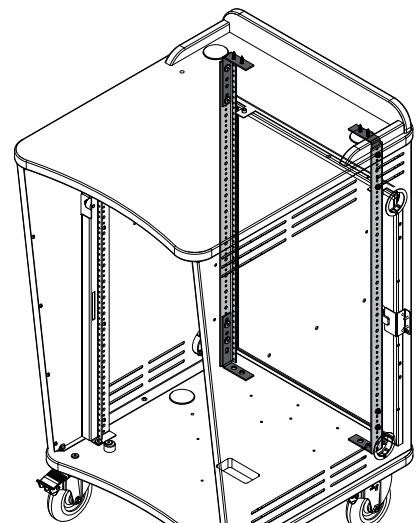

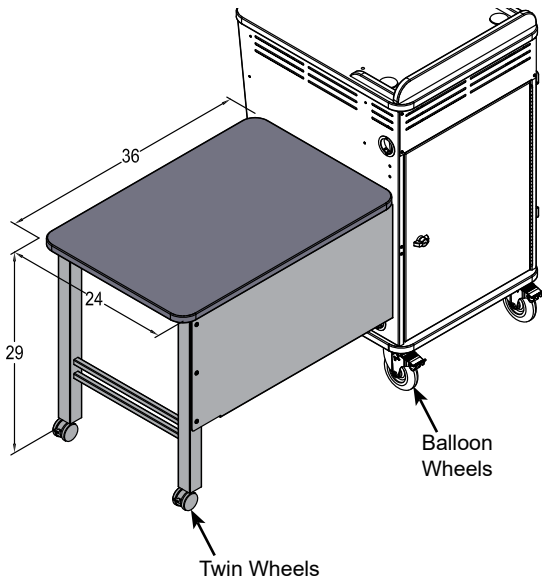

Inspiration Side Table - 55413

- For 36"H, or 42"H lecterns
- ADA-compliant
- Available with Twin-wheels casters for BW lecterns, or Glides for TK lecterns
- Mounts on left or right-side

Dimensions: 36"W [91.4 cm] x 24"D [61 cm] x 29"H [73.7 cm]
 Shipping weight: 62 lb [28.1 kg]

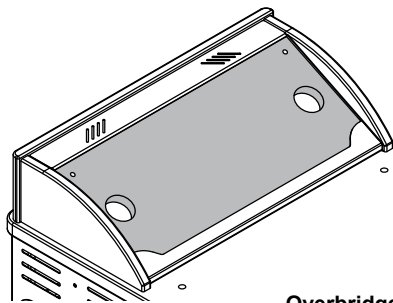
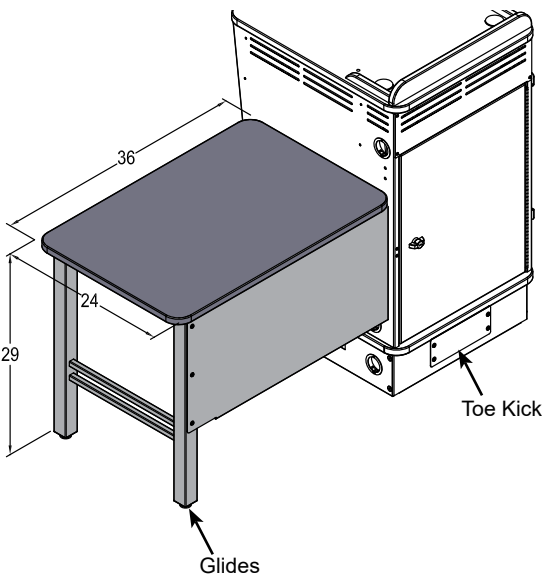

Overbridge Insert Panel - 96511

Contact Spectrum to specify cutout size(s) and position(s)

- For overbridge version only
- Overbridge not available separately
- Includes two 2" [5.08 cm] grommets with covers
- Shipping weight: 5.7 lb [2.6 kg]

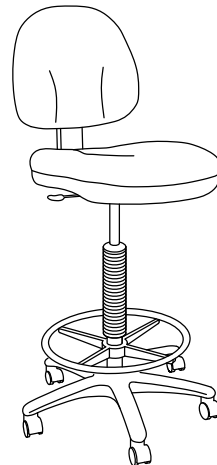

Adjustable Drafting Stool - 38202

- 40-52" height-adjustment via pneumatic cylinder
- 360° swivel
- Tilting backrest
- 18" diameter fixed foot ring
- 5-star base

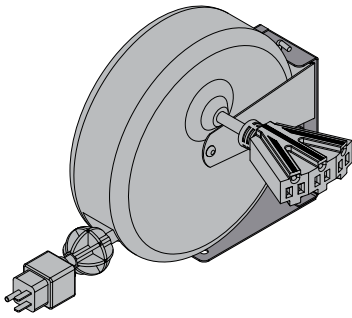

Universal Cord Reel Kit - 99037

- Includes universal mounting bracket
- Mounts inside lectern to base panel
- Adjustable ball stop and releasable cord-locking ratchet holds the cord at any length up to 15'
- cUL listed
- Customer-installed

| | |
|-----------------------------|---|
| Power cord: | 15' nominal, 12 AWG retractable power cord |
| Power receptacles: | <ul style="list-style-type: none"> • Molded 3-prong male plug with 15A breaker and reset button • Tri-tap (3-outlet) receptacle |
| Universal mounting bracket: | <ul style="list-style-type: none"> • 16-gauge steel • Black powder coat • Includes mounting screws |
| Unit weight: | 10 lb [4.5 kg] |
| Shipping weight: | 10.8 lb [4.9 kg] |

The cord reel is intended to provide temporary access to electrical outlets for Spectrum mobile lecterns. Check local electrical codes prior to installation.

Optional Universal Cord Reel
(Available positions on base)

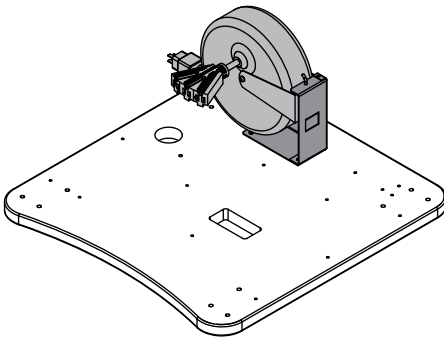

Vertical left
(takes up 6RU)

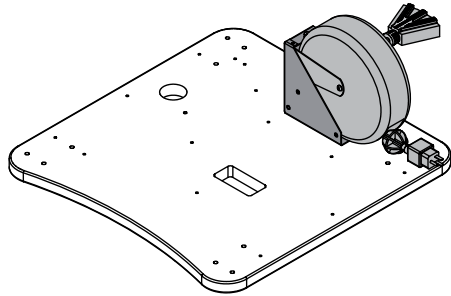

Vertical right
(takes up 6RU)

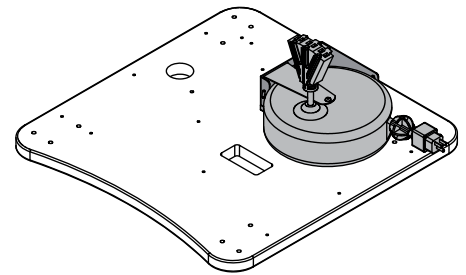

Horizontal right
(takes up 3RU)

Available rack spacing

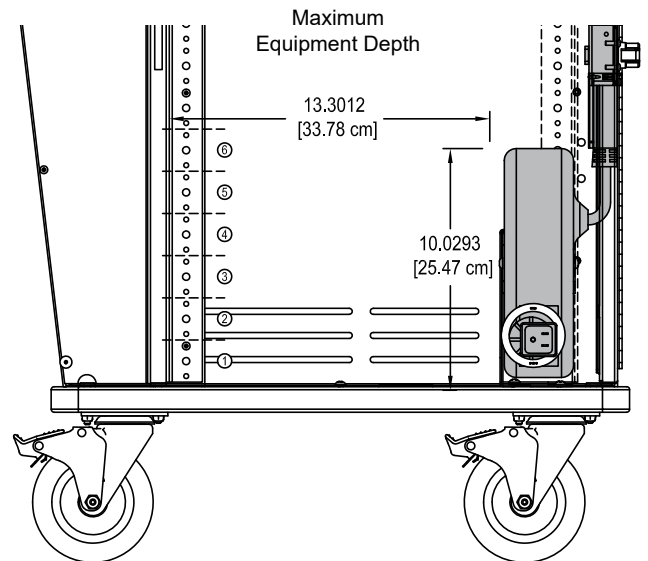
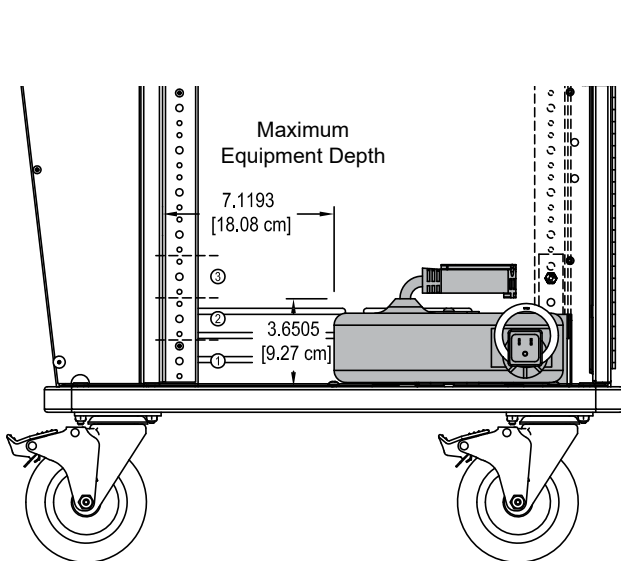

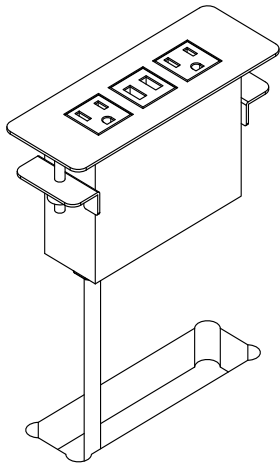

Power Module - 99058

- (2) AC power outlets
- (2) USB charge ports
- Aluminum housing and flange
- Thumbscrew clamps
- Requires worksurface cutout made by customer
- ETL-certified
- Available in black, silver, or white
- Customer-installed

| | |
|---------------------|--|
| Cutout required: | 5.65"W [14.35 cm] x 1.65"D [4.19 cm] |
| Power cord: | 10' [305 cm] 14AWG *3C power cord |
| Power receptacles: | 125V, 60hz, 15A tamper-resistant |
| USB charging ports: | 2.1A (10.5W) (not data-compatible) |
| Dimensions: | 6.38"W [16.2 cm] x 2.36"D [6 cm] x 3.54"H [9 cm] |
| Unit weight: | 2 lb [.9 kg] |
| Shipping weight: | 2.35 lb [1 kg] |



Product update
New USB-C Power Module version available. See details at:
www.spectrumfurniture.com

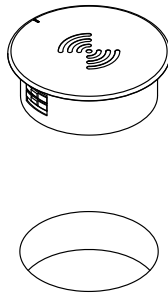

EM Wireless Charging Pad - 99057

- Uses electromagnetic technology to charge Qi V1.2 compliant IC devices ("Qi" enabled)
- LED to confirm pairing / charging
- Security tab prevents theft
- Customer-installed
- UL-certified

| | |
|------------------|--|
| Cutout required: | 3" dia (by customer) |
| Input: | DC 5V (with included DC5V.2A power adapter) |
| Output: | 5W max (with included DC5V.2A power adapter) |
| Power cord: | 8' [244 cm] with DC jack |
| Dimensions: | 3.5" dia [8.9 cm] x 1.125"H [2.9 cm] |
| Shipping weight: | 1 lb [.45 kg] |

Note: The unit requires a 7" diameter of clearance to work with Qi-enabled phones placed in any orientation. The 3" dia cutout should be located on the worksurface at least 3.5" from any edge.



7-Outlet Power Strip - 99024

- Electrical Rating: AC 125V, 15 Amps
- 1000 Joules surge capacity
- 12' cord length
- LED switch
- UL Listed
- Shipping weight: 1.9 lb [.86 kg]



Rack-mount Accessories

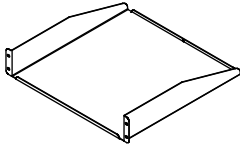

Cantilever Shelf - 2RU - 97504

- 16ga steel
- Shelf: 17.5"W [44.45 cm] x 18"D [45.7 cm] x 3.5"H [8.89 cm]
- Weight capacity: 50 lb [22.7 kg]
- Shipping weight: 8.1 lb [3.7 kg]

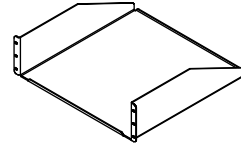

Cantilever Shelf - 3RU - 97502

- 16ga steel
- Shelf: 17.5"W [44.45 cm] x 18"D [45.7 cm] x 5.25"H [13.33 cm]
- Weight capacity: 80 lb [36.3 kg]
- Shipping weight: 9.2 lb [4.2 kg]

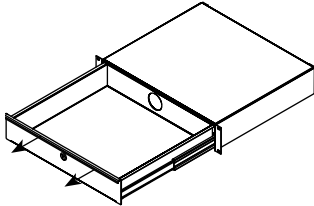

Locking Drawer - 2RU - 97527

- 16ga steel
- Drawer: 15.97"W [40.56 cm] x 14.56"D [36.98 cm] x 3"H [7.63 cm]
- Weight capacity: 50 lb [22.7 kg]
- Shipping weight: 15.85 lb [7.2 kg]

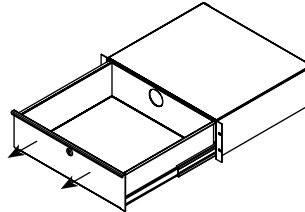

Locking Drawer - 3RU - 97526

- 16ga steel
- Drawer: 15.97"W [40.56 cm] x 14.56"D [36.98 cm] x 5.25"H [13.33 cm]
- Weight capacity: 50 lb [22.7 kg]
- Shipping weight: 18.5 lb [8.4 kg]

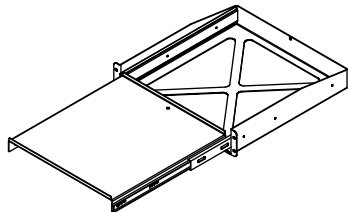

Pull-Out Shelf - 2RU - 97505

- 16ga steel
- 17.09"W [43.42 cm] x 18.12"D [46.03 cm] x 3.5"H [8.89 cm]
- Weight capacity: 50 lb [22.7 kg]
- Shipping weight: 15.6 lb [7.1 kg]

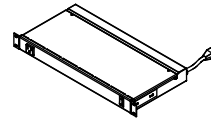

9-Outlet Power Strip - 1RU - 99021

- 8 outlets rear (breaker-protected)
- 1 convenience outlet front
- 115VAC, 60 Hz, 15 amps max
- 9' power cord
- Front LED power switch
- Enhanced surge protection
- ETL-listed, UL-listed
- 19"W [48.27 cm] x 9.25"D [23.5 cm] x 1.74"H [4.41 cm]
- Shipping weight: 8.7 lb [3.9 kg]

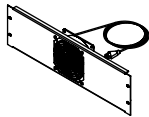

Single Fan - 3RU - 97507

- 50 cfm
- 120V~50/60 Hz, 15/13W
- RoHS
- 19"W [48.27 cm] x 1.56"D [3.97 cm] x 5.25"H [13.33 cm]
- Shipping weight: 3.78 lb [1.7 kg]

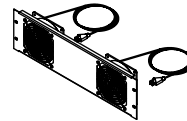

Double Fan - 3RU - 97506

- 100 cfm
- 120V~50/60 Hz, 15/13W
- RoHS
- 19"W [48.27 cm] x 1.56"D [3.97 cm] x 5.25"H [13.33 cm]
- Shipping weight: 5.47 lb [2.5 kg]

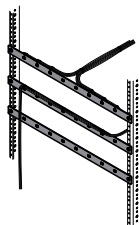

Wire Lace Kit - 95517

- Provides wire management
- Mounts to standard rack rails
- Includes (3) lace straps and mounting screws
- Includes (12) 5.5" zip ties
- Shipping weight: 1.25 lb [.57 kg]

See spectrumfurniture.com for the latest accessories and detailed warranty information.

Warranty

We will make it right for you!

Thanks for choosing Spectrum! Spectrum is committed to provide complete customer satisfaction. Each of our products is manufactured from the best materials available and each product is stringently monitored throughout the production process through our P.A.C.E. program (Product Assurance to meet Customer Expectations).

We expressly warrant that Spectrum products will be of good quality and workmanship and free from defect for the period set out in the warranty from the date of delivery.

For a listing of all product specific warranty terms please visit our website at:

<https://www.spectrumfurniture.com/en/resources/purchasing-terms-warranty>

1-800-235-1262

Toll-free HELPLINE

spectrum@spectrumfurniture.com