

## Technical Specifications

55104

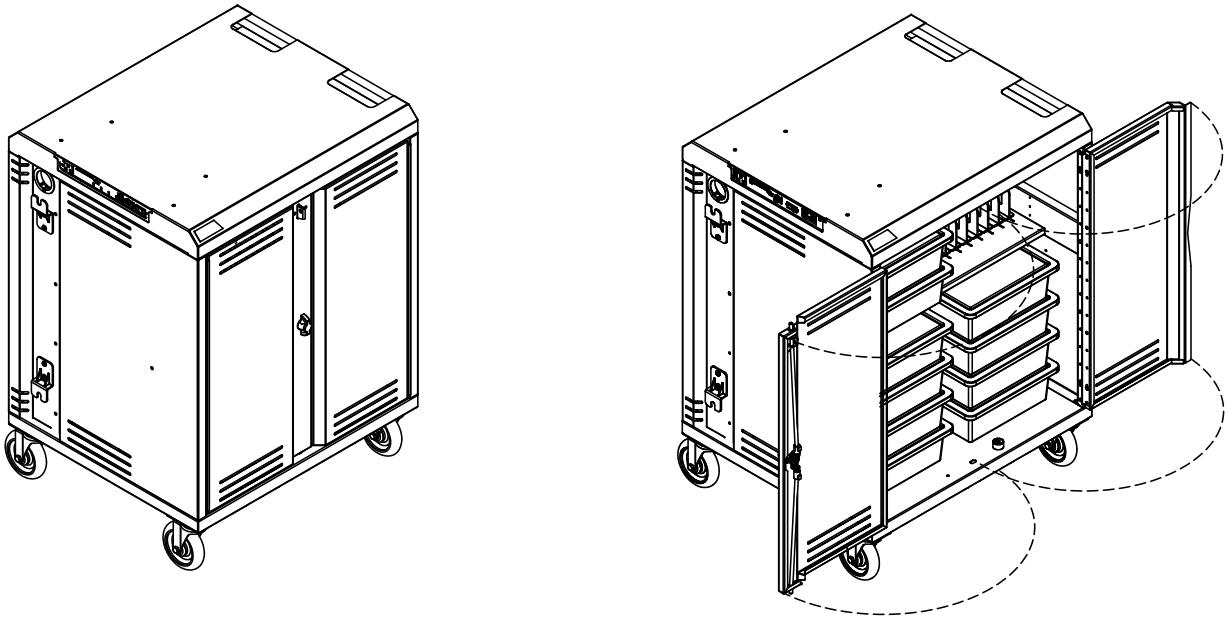

The Discover Cart was developed to store and transport educational robotics and coding systems (like WeDo® construction sets). It can also store and charge up to 10 notebooks, Chromebooks, or tablets. Flexible dividers protect the devices and locking doors and panel increase security. The cart's compact footprint and top handles provide easy mobility between rooms. This economical cart is made with heavy-gauge steel for security and powder-coated for a durable, long-lasting finish.



## Features and Benefits

- Stores, charges, and transports up to 10 devices (*most Chromebooks, tablets\*, and notebooks up to 15.6" diagonal*) as well as educational robotics and coding systems and supplies
- 1.3"W x 17.59"D x 13"H storage bays hold up to (10) devices
- Storage for up to (10) storage bins on lower shelf
- Small cart footprint (29"W x 25"D) saves valuable space
- Durable ABS plastic dividers protect devices from scratching (*dividers are removable to provide storage space for thicker devices*)
- Recessed lock and cord wrap design eliminates damage through doorways
- Heavy gauge student-side doors feature a recessed dual-bolt steel lock with padlock hasp. (*Padlock not included*).
- Heavy gauge instructor-side panel has a recessed padlock hasp for security. (*Padlock not included*).
- Devices and students are separated from AC line voltage
- Superior, all-metal overhead cord management system keeps charge cords organized above each device bay
- Replaceable, IEC (*quick-release*) 8' nominal 14 AWG, 3-wire power cord and external recessed cord wrap brackets provide easy power access
- Four inboard 5" balloon wheel plate casters (two locking, two non-locking) with metal construction and non-marring rubber provide easy rolling, and quiet transport (*rated for 300 lb each*)
- Integrated handles in top panel provides control and maneuverability
- Cart ships fully-assembled for quick, simple integration and deployment
- Durable powder coated steel chassis provides a long-lasting finish
- ETL certified to UL 60950-1 in the US and Canada for the cart and electrical system
- Warranted to be free of all defects in materials and workmanship for 10 years, electrical system 2 years
- Designed and assembled in Chippewa Falls, WI, USA
- Power switch provides continuous power to power unit (non current-sensing) **\*For most power adapters up to 65W**
- 10-outlet, (125V~/12A, 60Hz) universal power unit with rotated outlets works with most wall or inline adapters
- External power switch provides easy-access for safe power connection / disconnection
- External LED illumination indicate charge status while doors are closed
- Wiring tray on power-side provide convenient power adapter and wiring storage
- Ventilated doors and side panels keep devices and chargers cool, preventing overheating, and extending device life

### Color Options

Light Blue



White doors



# Construction

- 16-gauge top cover
- 20-gauge doors, side panels, power-side panel, and base
- All metal components are finished with a scratch-resistant powder coat epoxy
- ABS plastic dividers
- This cart is factory-assembled, packaged, and shipped on its own skid

Note: Do not place items weighing more than 50 lb [22.7 kg] on the top surface. Please remove or secure items before moving cart.

# Specifications

Nominal size	29"W x 25"D x 40"H		
Capacity	<ul style="list-style-type: none"> <li>• 10 Devices (most notebooks, Chromebooks, or tablets*)</li> <li>• (3) 3"H Project Trays (upper shelf)</li> <li>• (10) 3"H Project Trays (lower shelf)</li> </ul>	*Accessory power plug may be needed	
Device storage bays (nominal) <i>(Bold indicates factory-assembled height)</i>	1.271"W [3.234 cm]	x 18.439"D [46.83 cm] x	<ul style="list-style-type: none"> <li>• <b>11.613"H [29.5 cm]</b></li> <li>• 9.613"H [24.42 cm]</li> </ul>
Upper storage area (left-side) (nominal)	12.572"W [31.93 cm]		<ul style="list-style-type: none"> <li>• 10.613"H [26.96 cm]</li> <li>• 8.613"H [21.88 cm]</li> </ul>
Lower storage area (nominal) <i>(Bold indicates factory-assembled height)</i>	26.27"W [66.73 cm] x 23.402"D [59.44 cm] x		<ul style="list-style-type: none"> <li>• 16.351"H [41.53 cm]</li> <li>• 15.351"H [39 cm]</li> <li>• <b>14.351"H [36.45 cm]</b></li> <li>• <b>13.351"H [33.91 cm]</b></li> </ul>
Electrical	<ul style="list-style-type: none"> <li>• 10-outlet power unit <i>(Power unit is factory-installed in the tray, but can be easily moved to two different vertical mid-panel positions)</i></li> <li>• 125V~/12A, 60Hz</li> <li>• 15-amp breaker</li> </ul>	<ul style="list-style-type: none"> <li>• IEC quick-release (replaceable) 8' nominal, 14 AWG, 3-wire power cord</li> <li>• Locking power-side panel isolates and separates electrical line voltage from students</li> <li>• ETL recognized (certified to 60950-1)</li> </ul>	
Charging options (See p.3 for specs)	<div style="border: 1px solid black; padding: 5px;"> <p><b>⚠</b> Note: The customer should be aware of the amp draw of the devices used with this cart-especially when maxing out the storage and charging capacity. Exceeding 15 amps will trip the circuit breaker. Please consult the owners manual of your specific device for power consumption information.</p> </div>		
5" Balloon Wheels	Weight capacity 300 lb [136.2 kg] each (two locking, two non-locking)		
Certifications / Compliance	<ul style="list-style-type: none"> <li>• ETL certified to UL 60950-1</li> </ul>	<ul style="list-style-type: none"> <li>• Meets or exceeds applicable ANSI-BIFMA test standards</li> </ul>	
Unit weight (nominal)	132 lb [60 kg]		
Shipping weight (nominal)	180 lb [81.7 kg]		

Specifications subject to change without notice

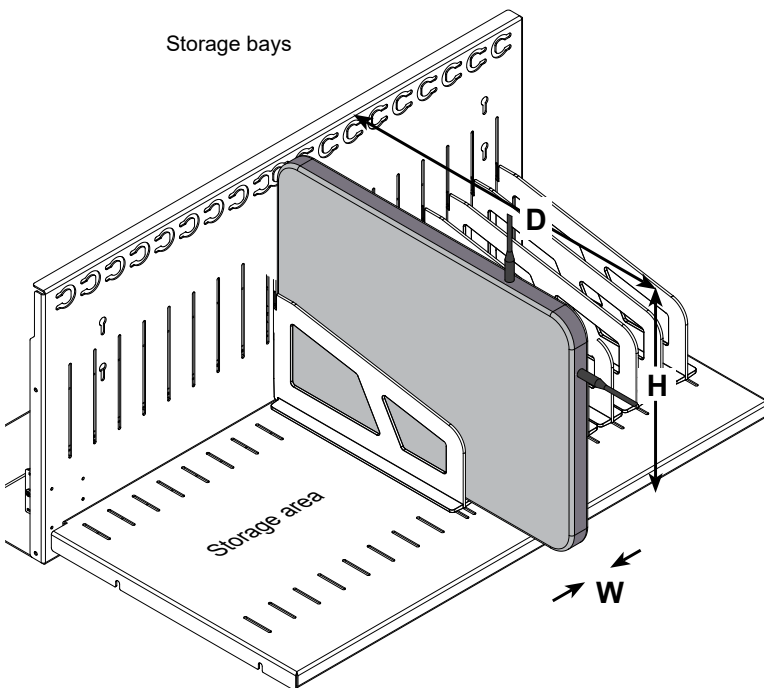

Devices must be placed in the bays with the charge plug on one of the two exposed edges shown.

## 5" Balloon Wheel

Note: (2) locking, and (2) non-locking casters are included on each unit.

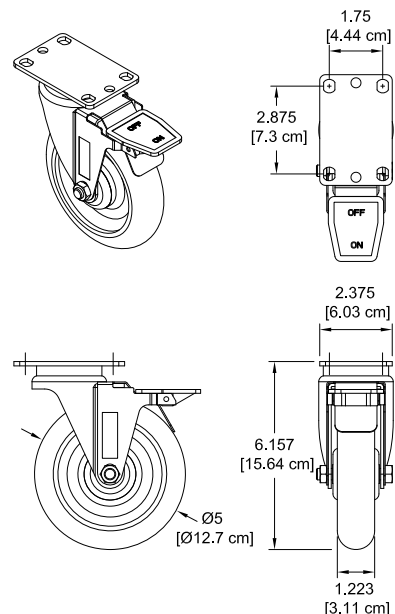

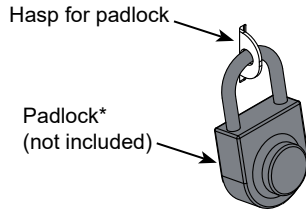

\*Padlocks with a shackle diameter up to 11/32" [9mm] can be used

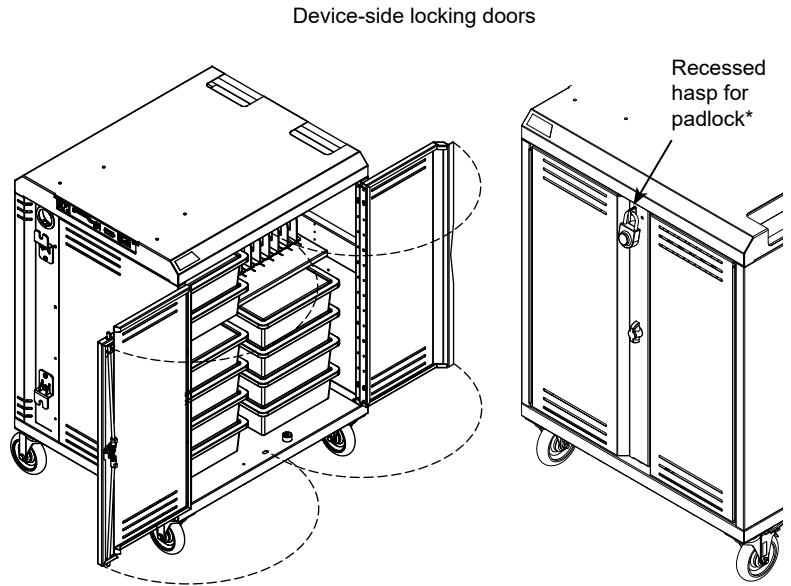
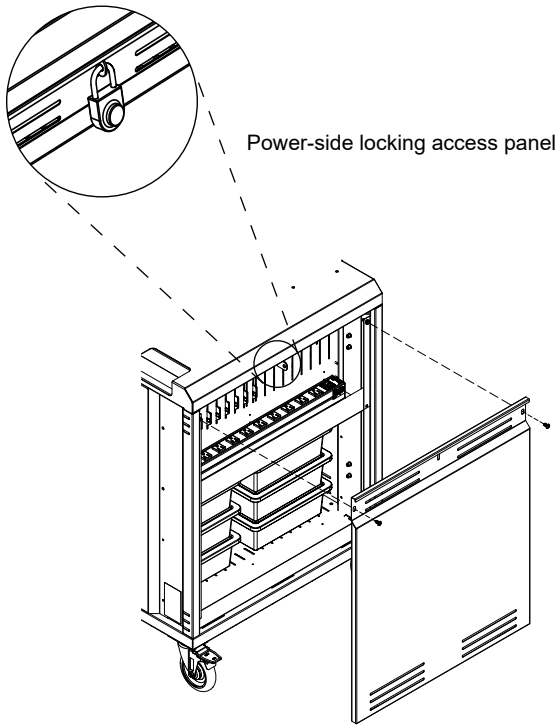

### Power Switch

The Power Switch provides continuous power to all power units.

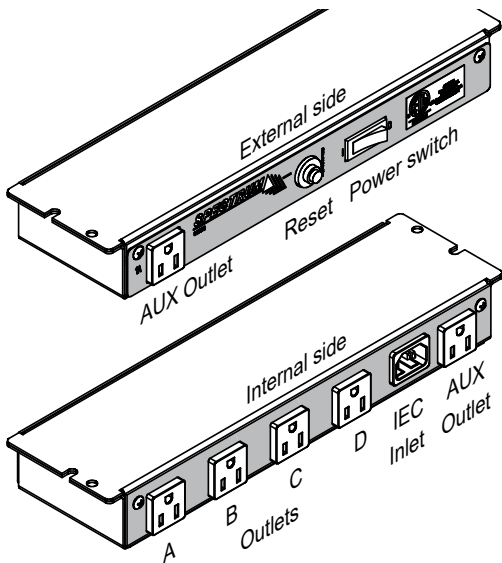

- Four continuous power-unit dedicated outlets (labeled A, B, C, D)
- Two auxiliary outlets (1 external, 1 internal)
- ETL certified to UL 60950-1

Input:	125V~/12A, 60Hz
Breaker:	15A, 250 VAC
Outlets:	4 timed (A, B, C, D) up to 10A
Auxiliary outlets:	1A each (controlled by main power switch)
Power Cord:	IEC quick-release (replaceable) 8' nominal, 14 AWG, 3-wire
Power switch:	15A (externally accessible)

\*Total maximum wattage will be impacted by actual charge adapter wattage and number of charge adapters per cart.

✓	External auxiliary outlet
✓	Internal auxiliary outlet
✓	External on/off switch
✓	4 bank
✓	*For most power adapters up to 65W
✓	ETL certified to 60950-1

Discover Cart

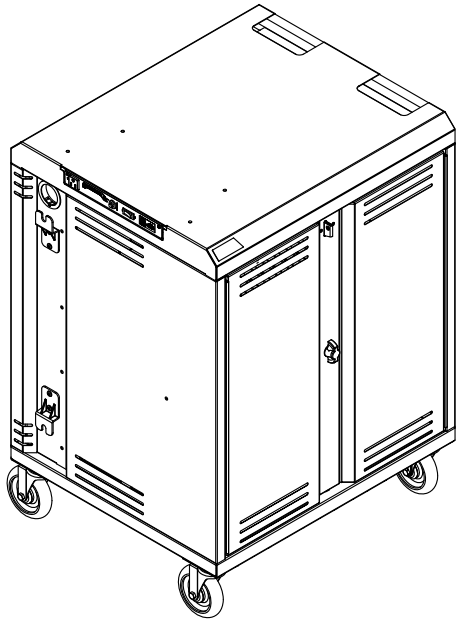

Power-side panel with hasp

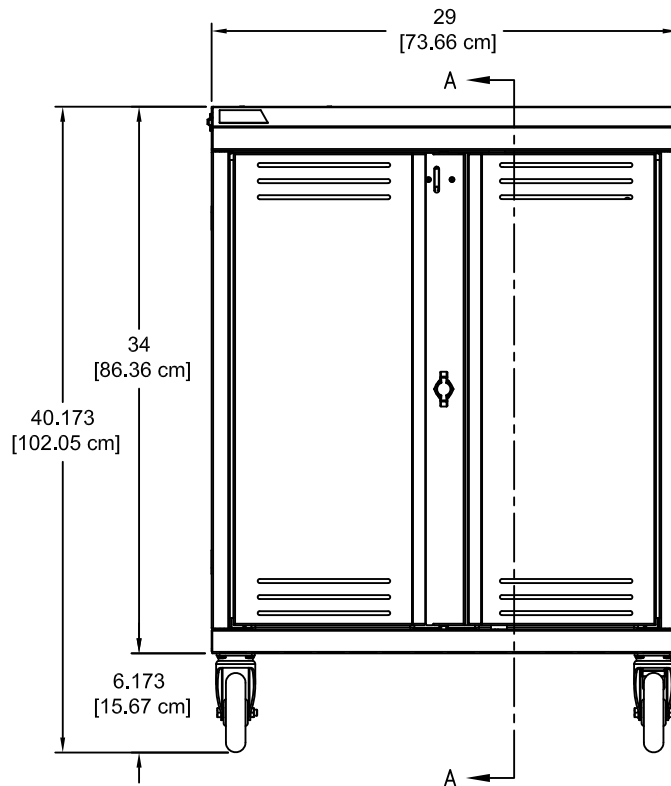
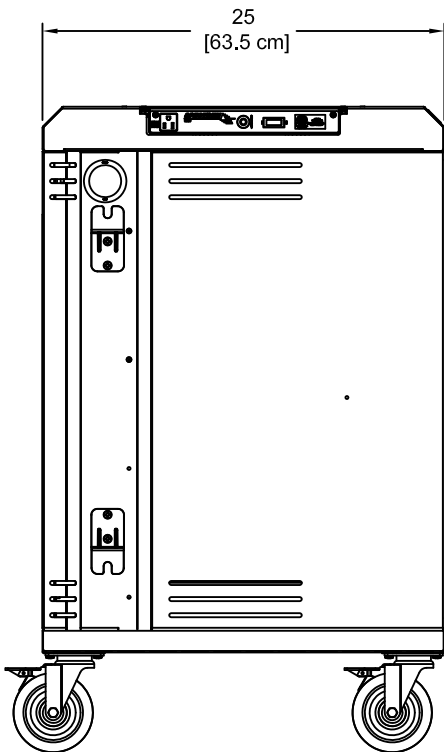
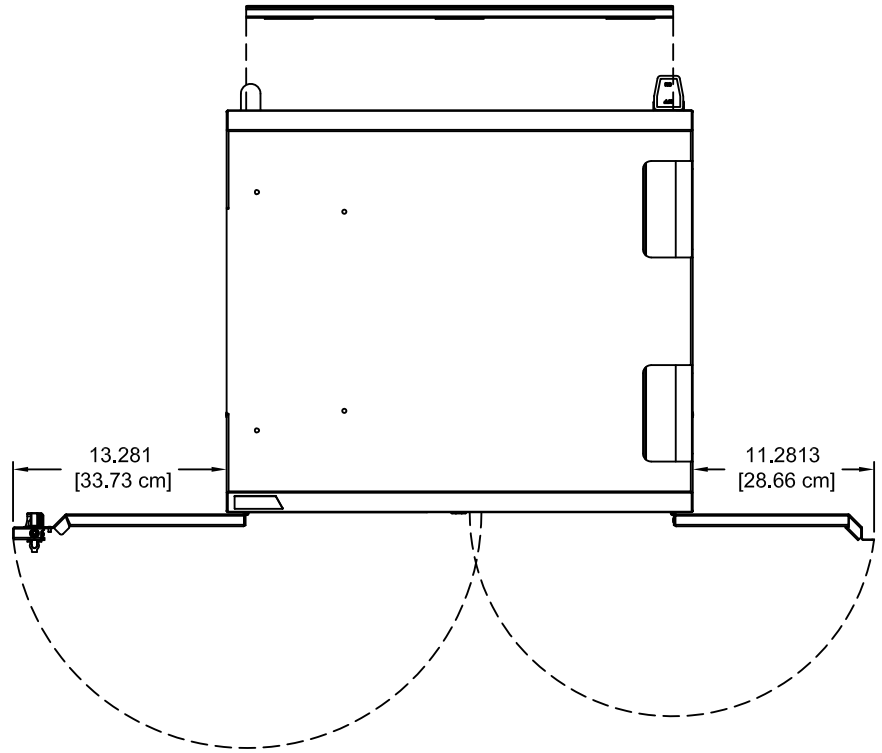

Section view A-A

Device side

Power side

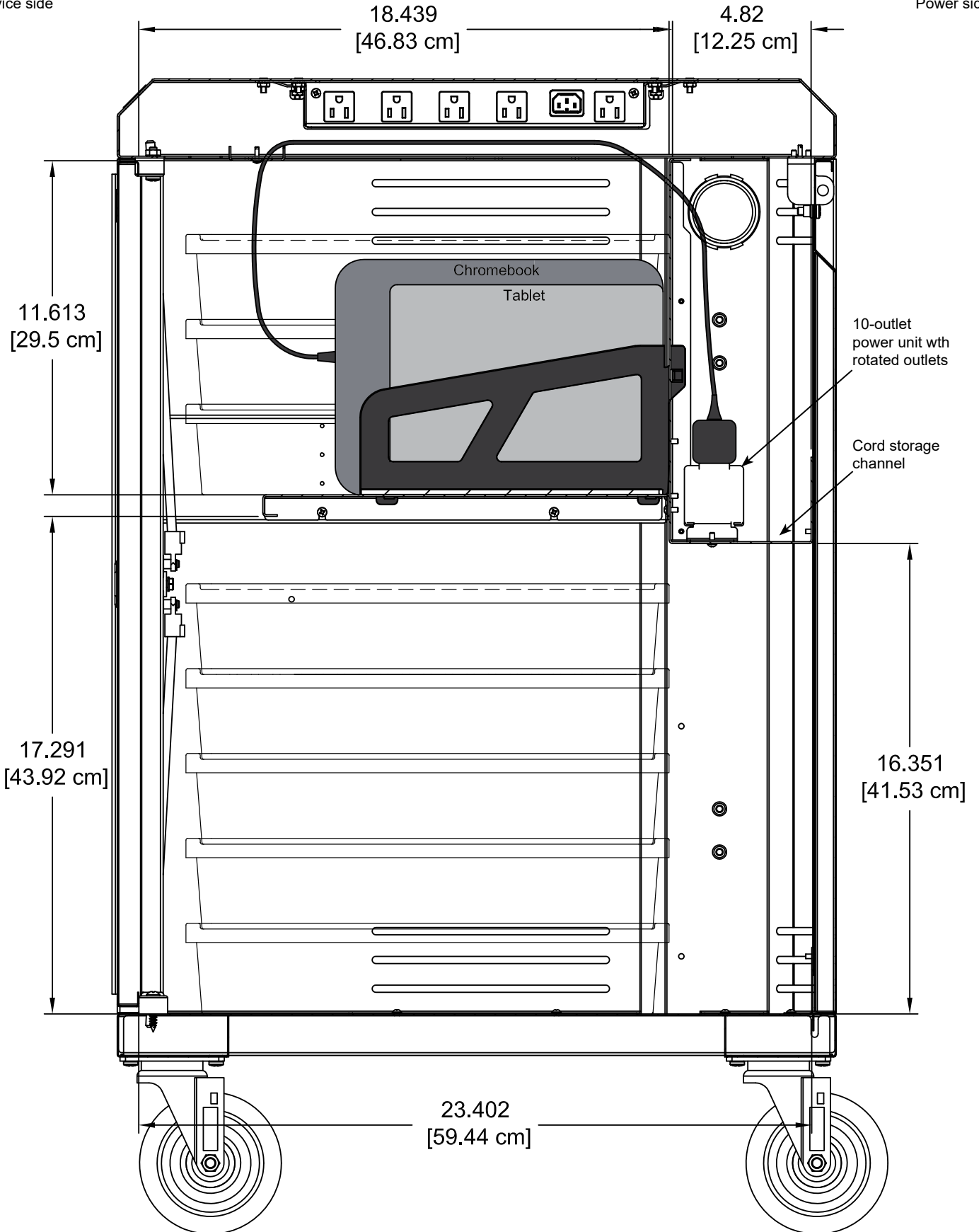

Discover Cart  
Device side view wiring diagram  
(shown with doors open)

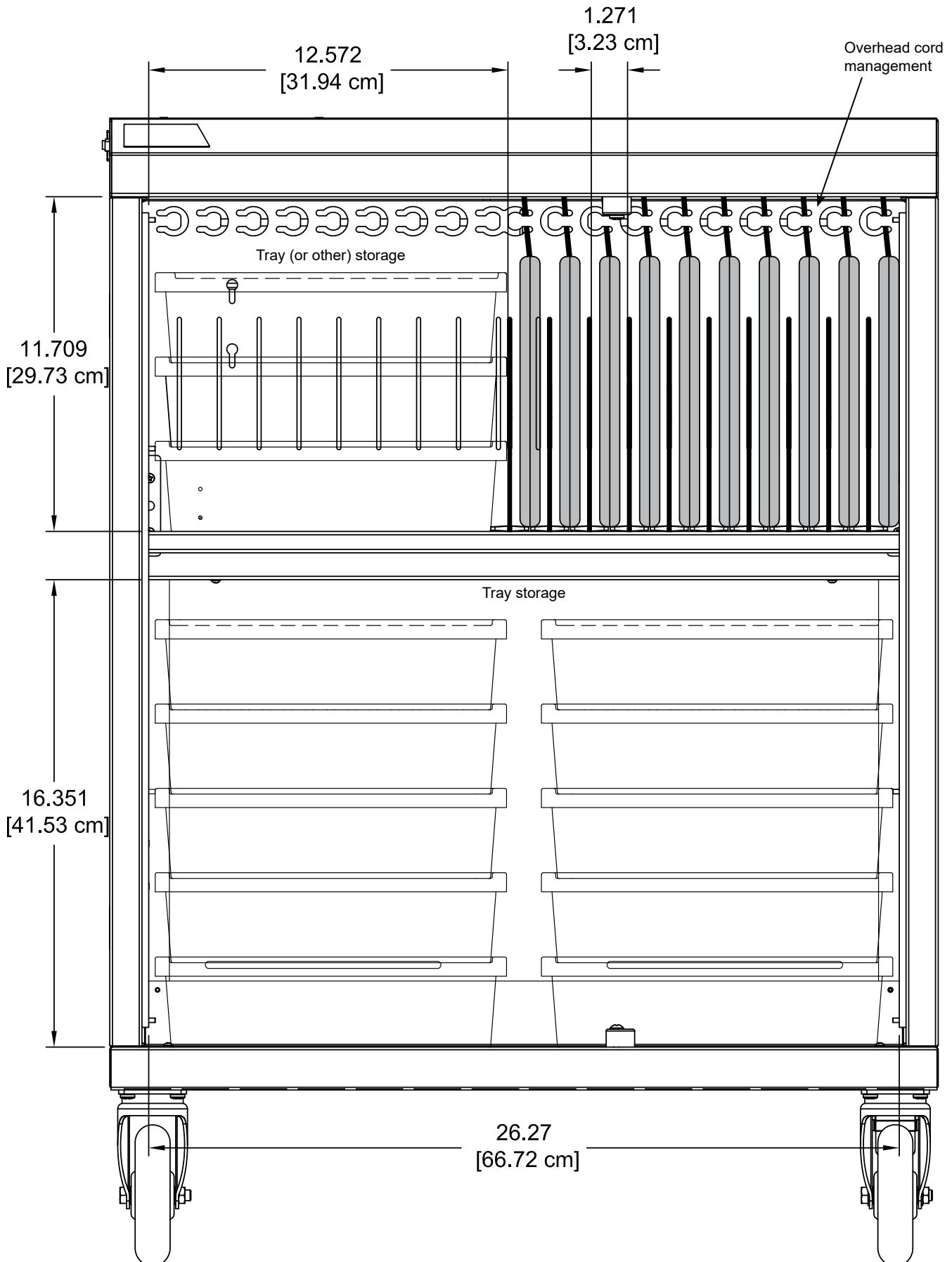

Discover Cart  
Power side wiring diagram  
(shown with locking panel removed)

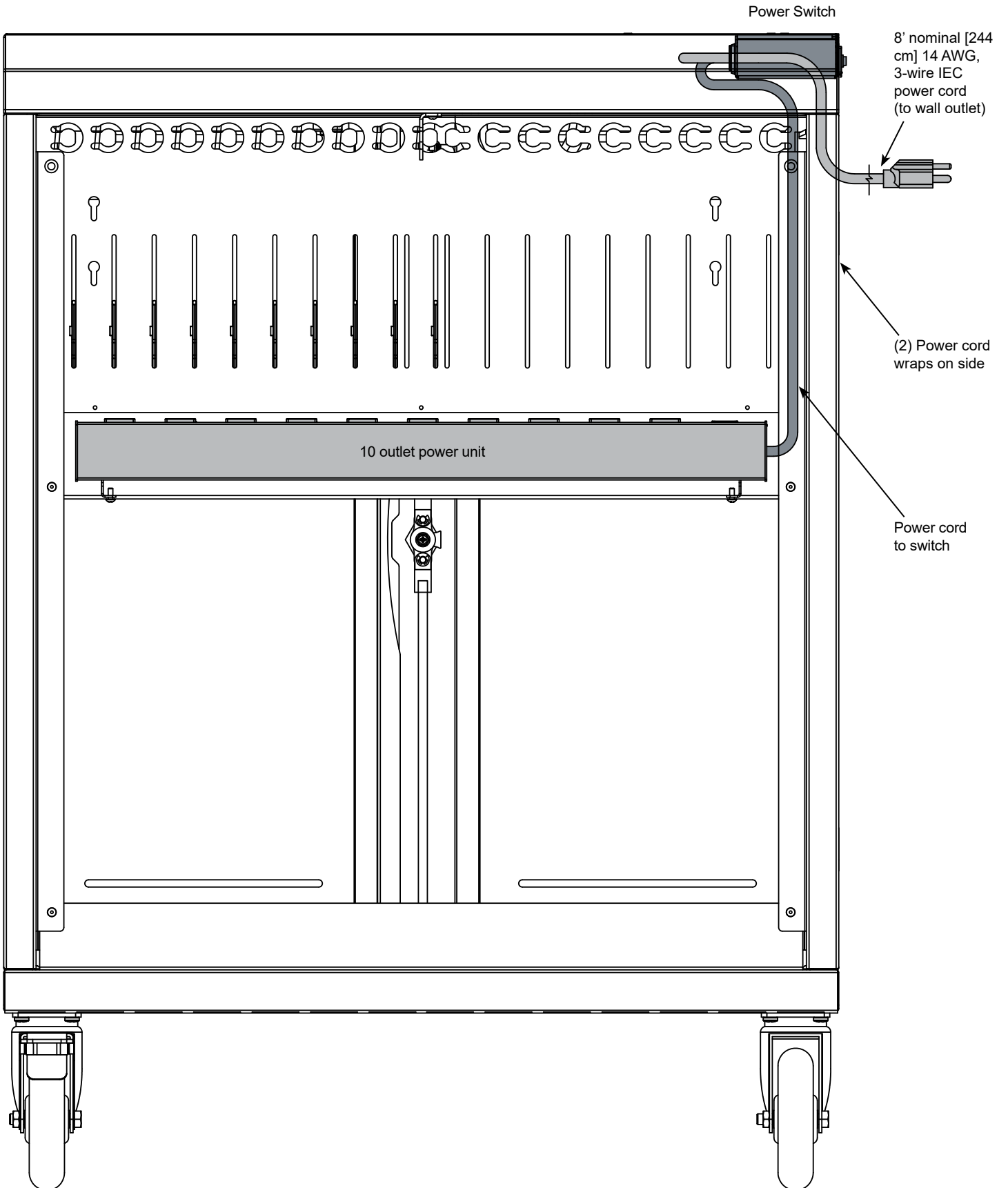

Rotated outlet spacing

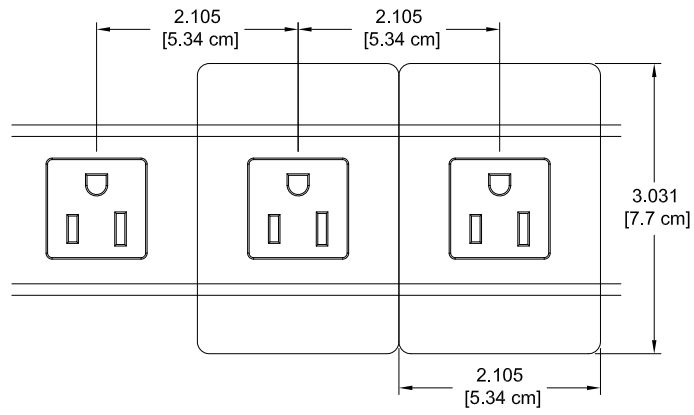
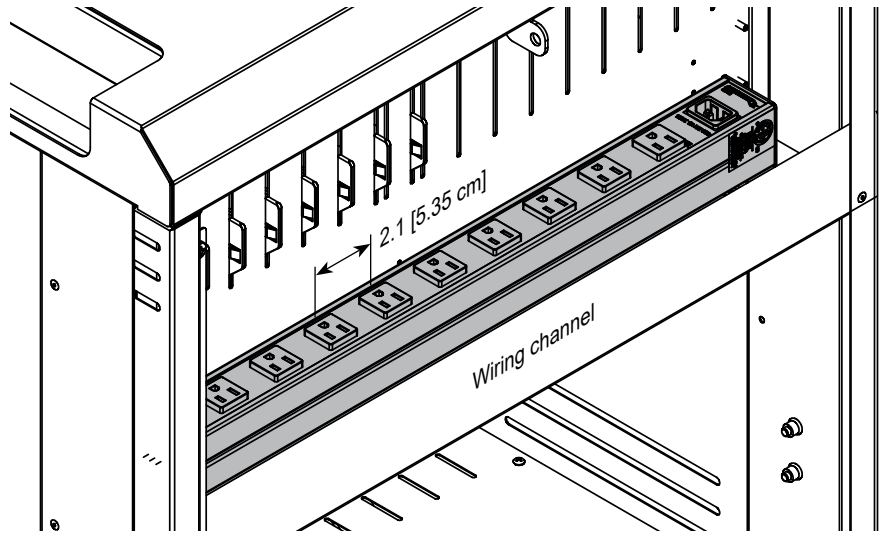



## Accessories

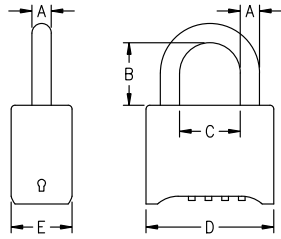

A	.3125" [7.9 mm]
B	1" [25.4 mm]
C	.983" [25 mm]
D	2.07" [52.5 mm]
E	.987" [25.1 mm]

### Re-programmable 4-digit Combination Lock - 95536

- Set your own 4-digit personalized combination (up to 10,000 options)
- 5/16" hardened steel shackle for cut-resistance
- Black powdercoated die-cast body for durability
- Change key included
- Unit weight: .55 lb [.25 kg]



### Project Trays w/ lids - 10-pack - 95006

- 12.3"W x 16.8"D x 3"H
- Drop-resistant plastic
- Includes 10 blue trays, and 10 translucent lids
- Unit weight (ea): 1.88 lb [.85 kg]
- Shipping weight: 11 lb [5 kg]



### White Boards (12 Pack) - 95014WD

- 9"W [22.86 cm] x 12"L [30.48 cm]
- Double-sided whiteboard surface for dry erase markers

See [spectrumfurniture.com](http://spectrumfurniture.com) for the latest accessories and detailed warranty information.

# Warranty

## We will make it right for you!

Thanks for choosing Spectrum! Spectrum is committed to provide complete customer satisfaction. Each of our products is manufactured from the best materials available and each product is stringently monitored throughout the production process through our P.A.C.E. program (Product Assurance to meet Customer Expectations).

We expressly warrant that Spectrum products will be of good quality and workmanship and free from defect for the period set out in the warranty from the date of delivery.

**For a listing of all product specific warranty terms please visit our website at:**

<https://www.spectrumfurniture.com/en/resources/purchasing-terms-warranty>

**1-800-235-1262**

Toll-free HELPLINE

**spectrum@spectrumfurniture.com**



Spectrum Industries is  
Certified ISO 9001:2015