

Technical Specifications

55532

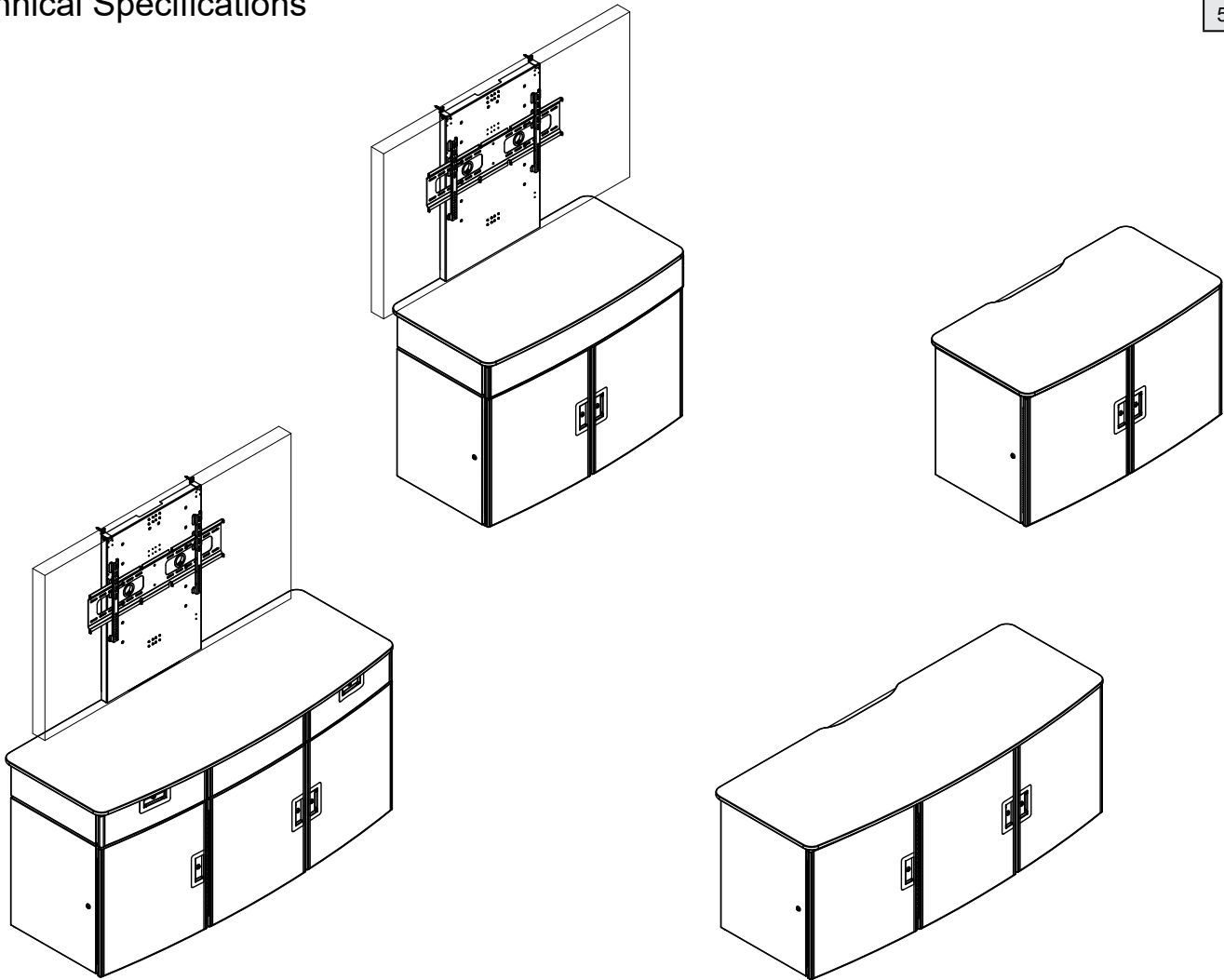

The AV Credenza is a fully customizable credenza that can accommodate AV equipment using a removable rack cube, or fixed rack rail in a sleek modern finish. Available in 2, or 3 bay models, the credenza can be used in conference, training, or classrooms. Spectrum's technology enhanced credenza is available with display stands to incorporate TV monitors, eliminating wall mounted displays.

Features and Benefits

- Available in 2-bay (50.5"), or 3-bay (75") versions
- Available with 13RU fixed rack rail or 12RU removable rack cube(s)
- Locking side and back panels simplify accessibility and component installation
- Optional cam lock hasp doors available provide superior protection and security
- Ventilation throughout keeps components cool, preventing overheating, and extending device life
- Optional riser provides additional storage space and front mounting location for power module
- Removable side panels on riser versions provide full access
- Optional 12RU rack cube(s) provide removable rack mount capability
- Optional 13RU fixed rack rail provides stationary rack mount capability
- Optional display stand provides monitor mounting
- Optional dual display mount provides dual monitor mounting
- Optional Camera mount provides mounting location for a video teleconferencing camera
- Optional power module provides worksurface power
- Ships fully-assembled for quick, simple integration and deployment
- Durable powder coated steel chassis provides a long-lasting finish
- Designed and assembled in Chippewa Falls, WI, USA

Color Options

Available in Spectrum Expressions colors.
See spectrumfurniture.com for complete color information.

Ordering Instructions

Spectrum has designed this product to receive the useful options shown here.
To ensure your options are ordered correctly please call 1-800-235-1262.

Construction

- 14-gauge doors, 16-gauge chassis
- All metal components are finished with a scratch-resistant powder coat epoxy
- Top panel is constructed from 3/4" NAF (No Added Formaldehyde) composite board
- Top panel edges are covered with 3mm vinyl edgeband
- Factory-assembled, packaged, and shipped on its own skid. Display stand requires customer assembly.

Specifications

Bay capacity (nominal)	20.75"W [52.7 cm] x 19.531"D [49.6 cm] x 22.968"H [58.3 cm]	
Certifications / Compliance	<ul style="list-style-type: none"> • SCS Indoor Advantage Certified 	<ul style="list-style-type: none"> • Meets or exceeds applicable ANSI-BIFMA test standards
Unit weight (nominal)	248 lb [113 kg] - 2-Bay w/ panels 237 lb [108 kg] - 2-Bay w/ doors	350 lb [159 kg] - 3-Bay w/ panels 355 lb [161 kg] - 3-Bay w/ doors
Shipping weight (nominal)	278 lb [126 kg] - 2-Bay w/ panels 267 lb [121 kg] - 2-Bay w/ doors	380 lb [173 kg] - 3-Bay w/ panels 385 lb [175 kg] - 3-Bay w/ doors

Specifications subject to change without notice

Add 24 lb [10.9 kg] for 2-bay riser
Add 44 lb [20 kg] for 2-bay riser w/ drawers

Add 36 lb [16.3 kg] for 3-bay riser
Add 56 lb [25.4 kg] for 3-bay riser w/ drawers

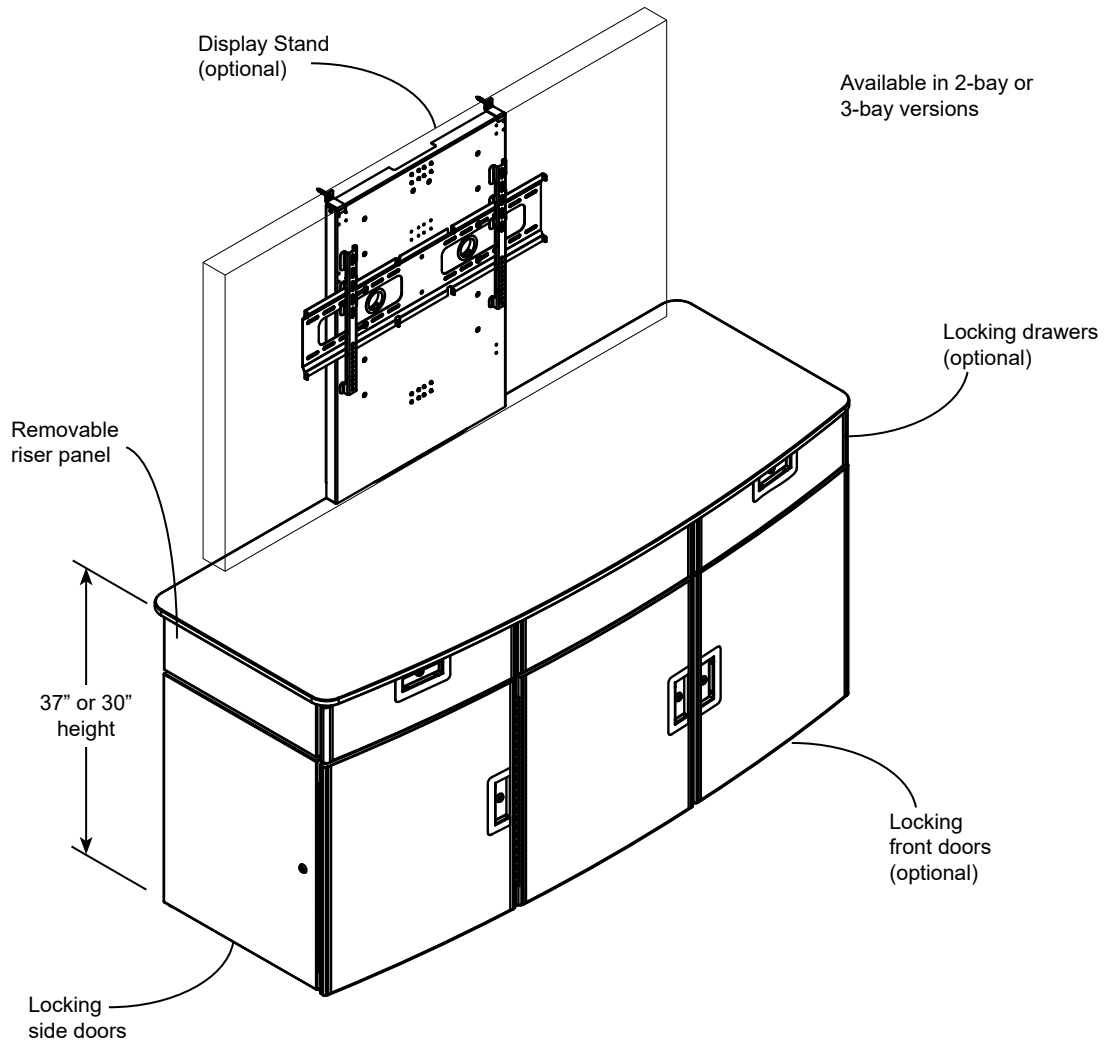

Bays

ORDER CODE 2 = 2-Bay

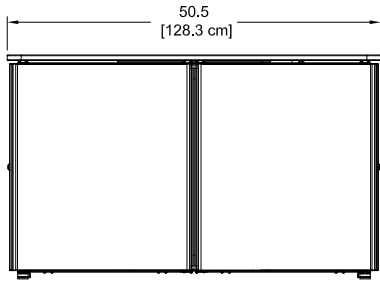

ORDER CODE 3 = 3-Bay

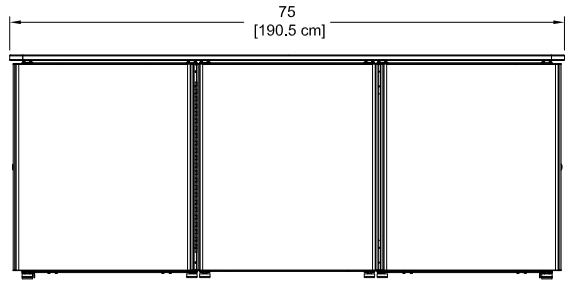

Height

ORDER CODE 2 = 30"H

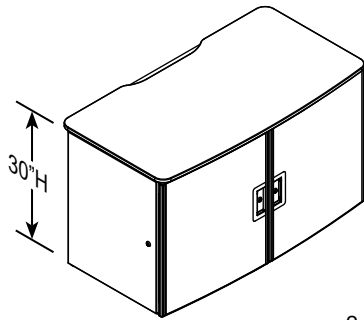

2-Bay

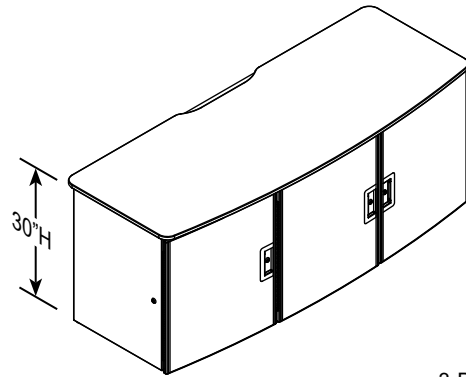

3-Bay

ORDER CODE 4 = 37"H

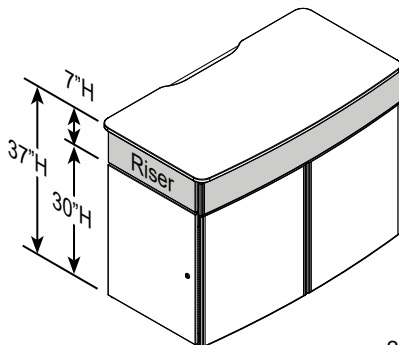

2-Bay

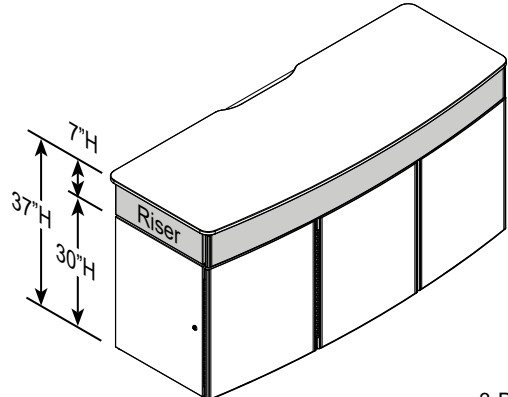

3-Bay

ORDER CODE 5 = 37"H w/ locking drawers

Note: When specified, two drawers are included. On 3-bay credenzas, a center non-functioning panel is included. This can be used to mount a power module if needed.

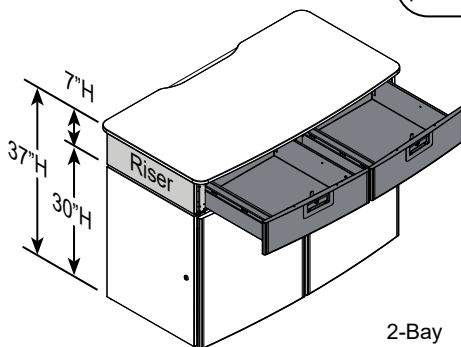

2-Bay

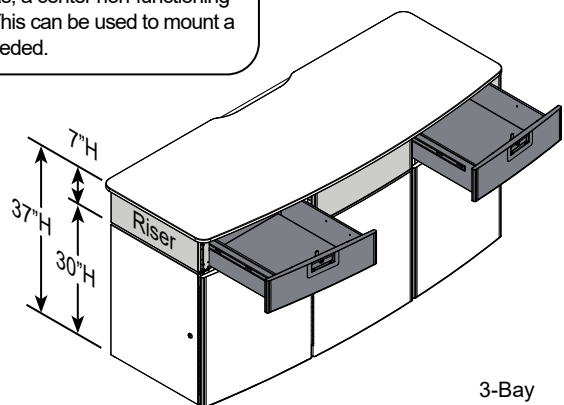

3-Bay

ORDER CODE 2 = Solid laminate panels - non locking

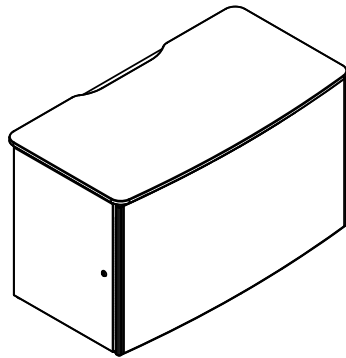

2-Bay

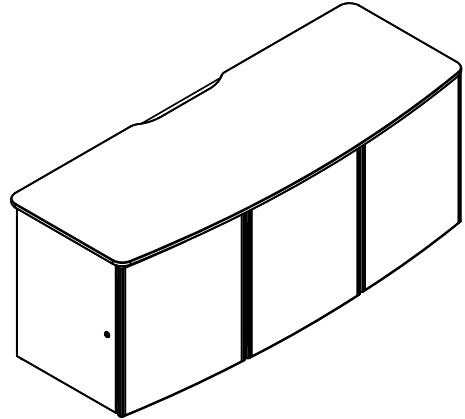

3-Bay

ORDER CODE 3 = Solid laminate doors - locking

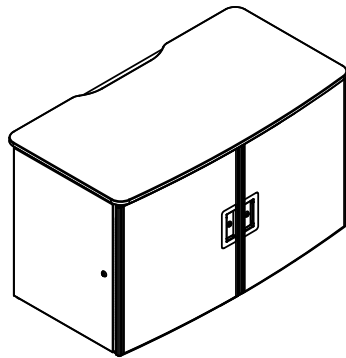

2-Bay

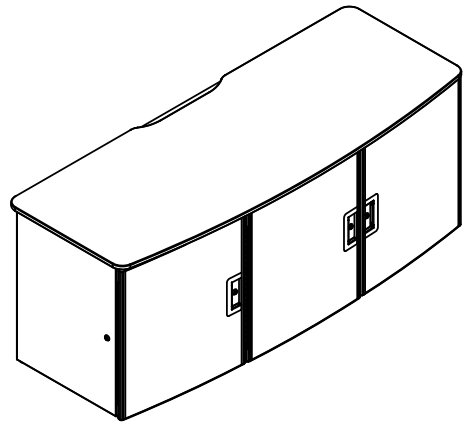

3-Bay

ORDER CODE 4 = Acrylic panels - non-locking

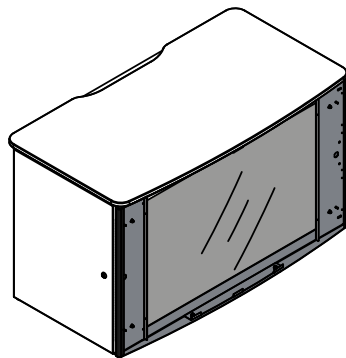

2-Bay

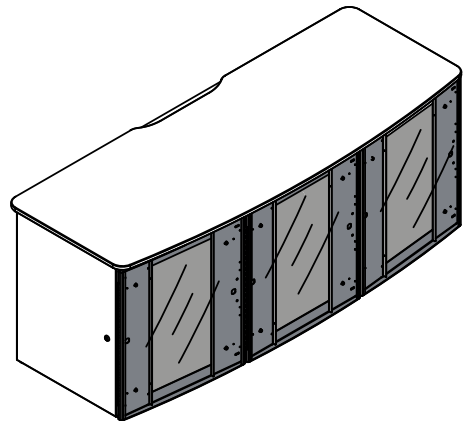

3-Bay

ORDER CODE 5 = Acrylic doors - locking

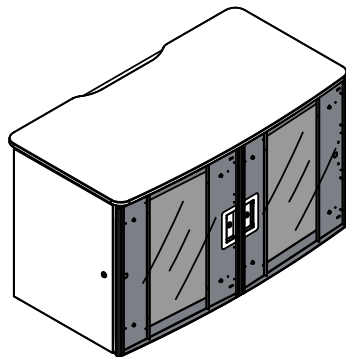

2-Bay

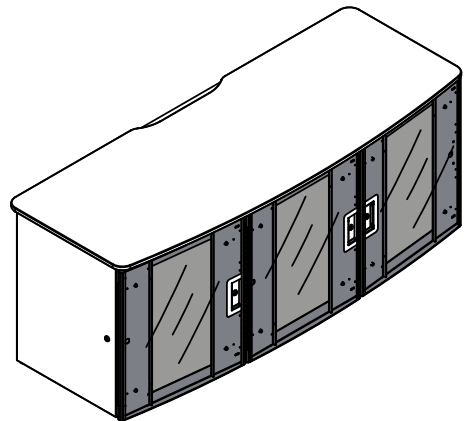

3-Bay

ORDER CODE 0 = None

Rack options dependent on bays ordered. Request a quote online for details.

- ORDER CODE A** = Fixed 13RU left bay
- ORDER CODE B** = Fixed 13RU right bay
- ORDER CODE C** = Fixed 13RU center bay
- ORDER CODE D** = Fixed 13RU left, right bays
- ORDER CODE E** = Fixed 13RU left, center, right bays

(3-Bay unit only)
(3-Bay unit only)

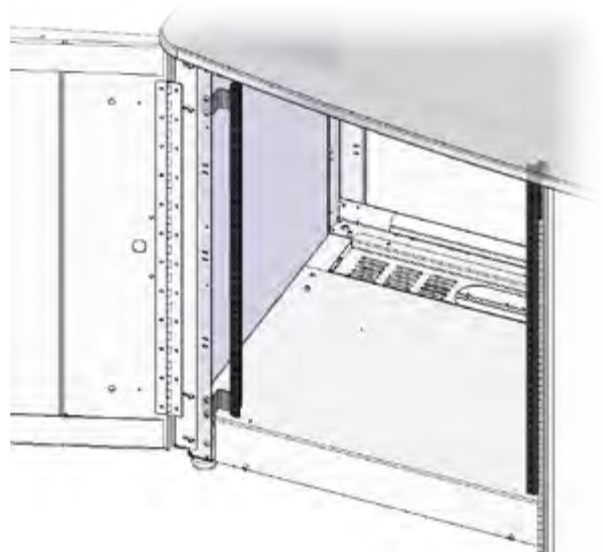

ORDER CODE F = 1 removable 12RU Rack cube

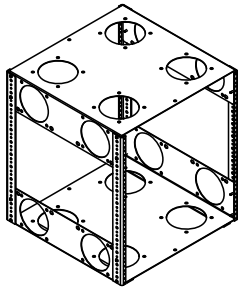

ORDER CODE G = 2 removable 12RU Rack cubes

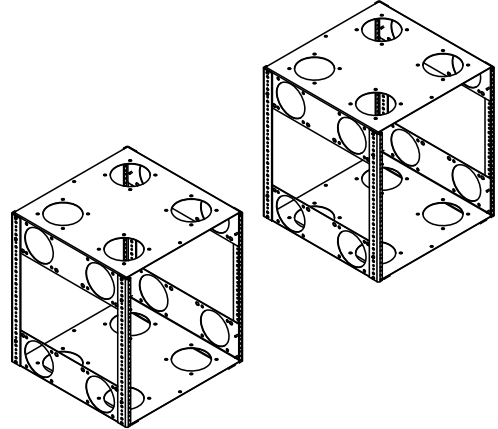

ORDER CODE H = 3 removable 12RU Rack cubes

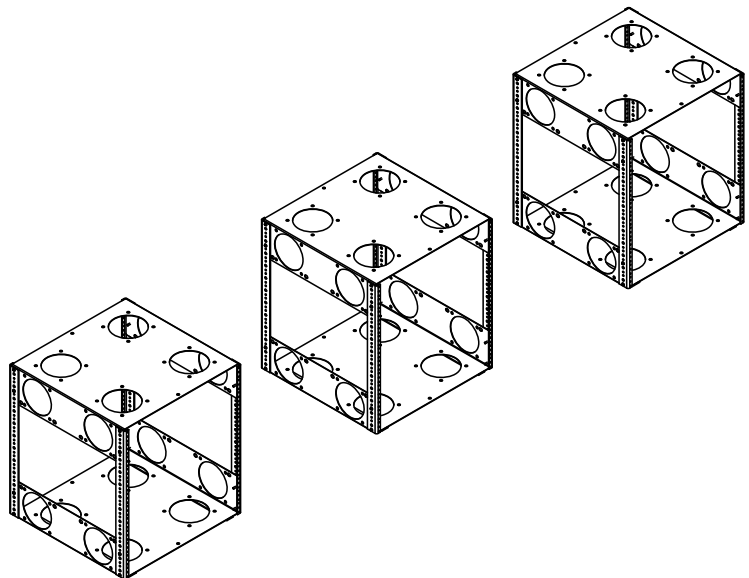

ORDER CODE 0 = None

ORDER CODE A = Power Module - Black

ORDER CODE B = Power Module - Silver

ORDER CODE C = Power Module - White

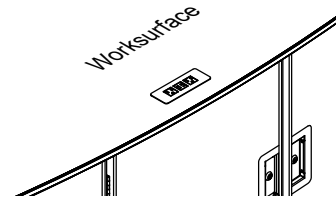
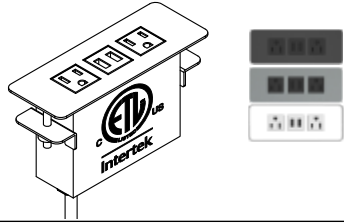

ORDER CODE D = Power Module - Black & EM Wireless Charging Pad

ORDER CODE E = Power Module - Silver & EM Wireless Charging Pad

ORDER CODE F = Power Module - White & EM Wireless Charging Pad

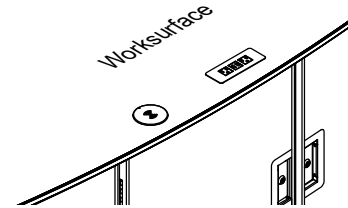

ORDER CODE G = Wireless Charging Pad

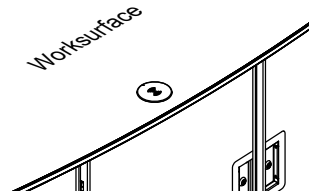
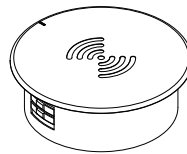

ORDER CODE H = Custom cutout in work surface

See p.11 for maximum cutout areas

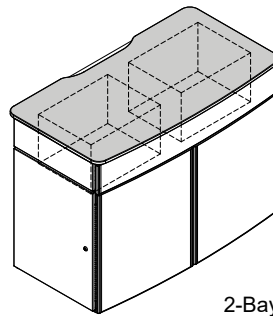

2-Bay

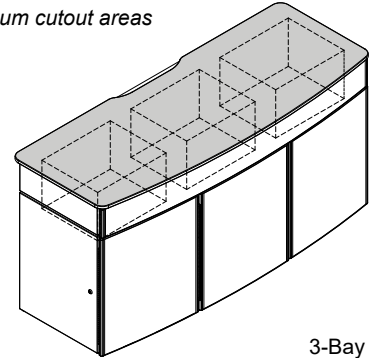

3-Bay

ORDER CODE J = Custom cutout in riser panel

See p.12 for maximum cutout areas

ORDER CODE K = Power Module in riser panel - Black

ORDER CODE L = Power Module in riser panel - Silver

ORDER CODE M = Power Module in riser panel - White

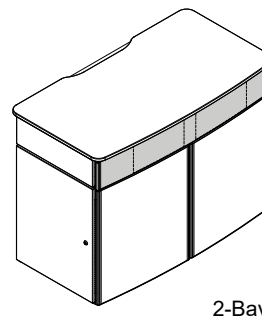
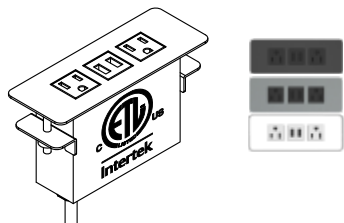

2-Bay

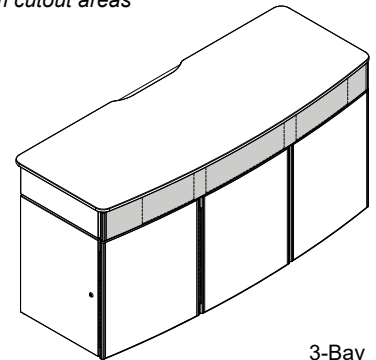

3-Bay

Display Options

Display options dependent on bays ordered. Request a quote online for details.

Note: Display stand requires anchoring to wall-hardware included.

Note: If a display stand is specified, a clearance cutout (or cutouts) will be designed into the rear worksurface edge to accommodate.

ORDER CODE 0 = None

ORDER CODE A = (1) Single display

**Most common display option*

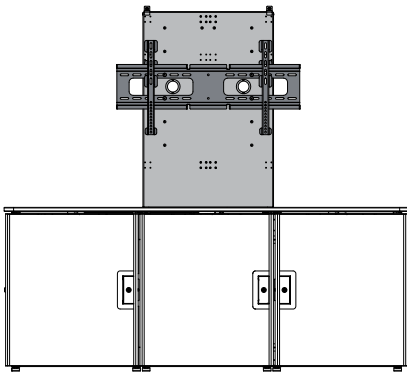

ORDER CODE B = (2) Single displays

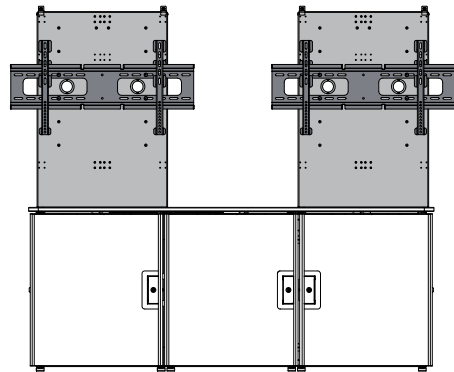

ORDER CODE D = (1) Dual display

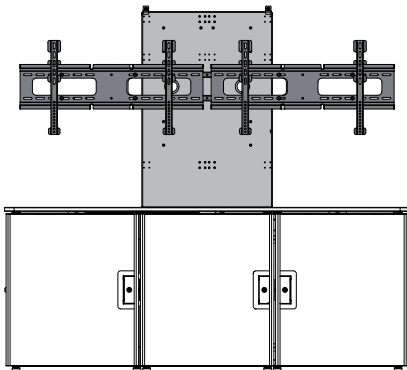

ORDER CODE E = (2) Dual displays

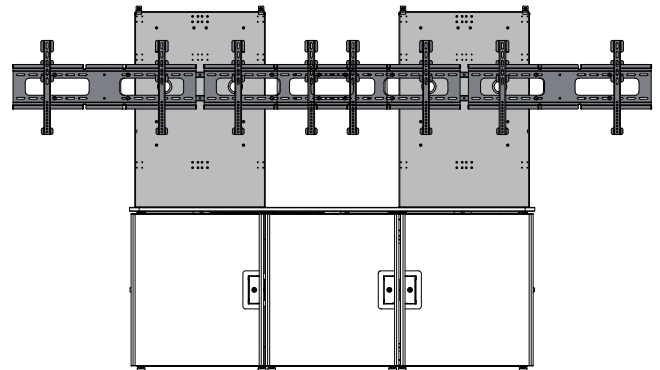

Camera Mount

ORDER CODE 0 = None

ORDER CODE 1 = Camera Mount

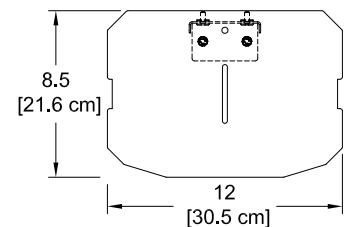
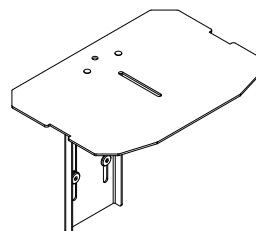

2-Bay AV Credenza
(shown with doors)

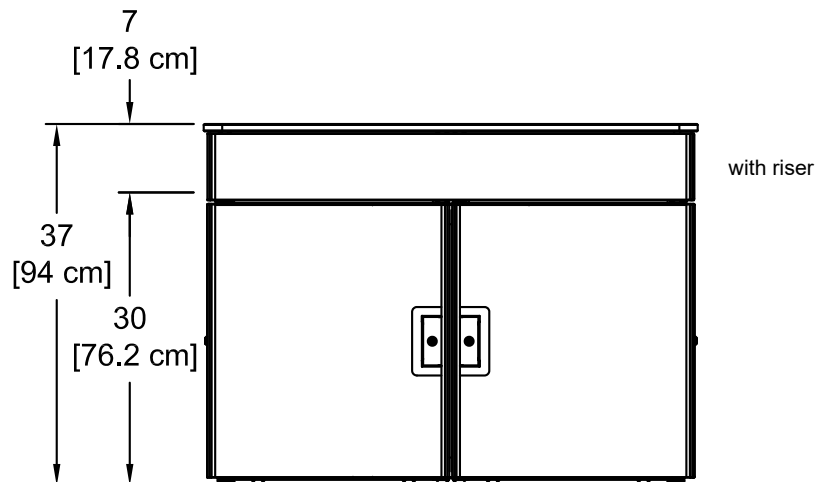
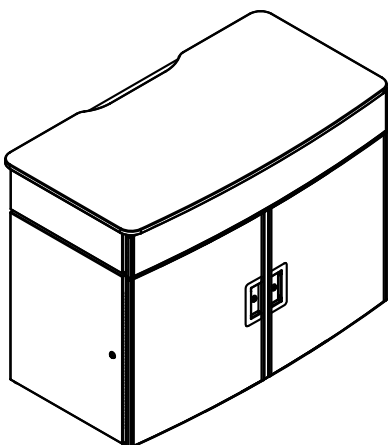
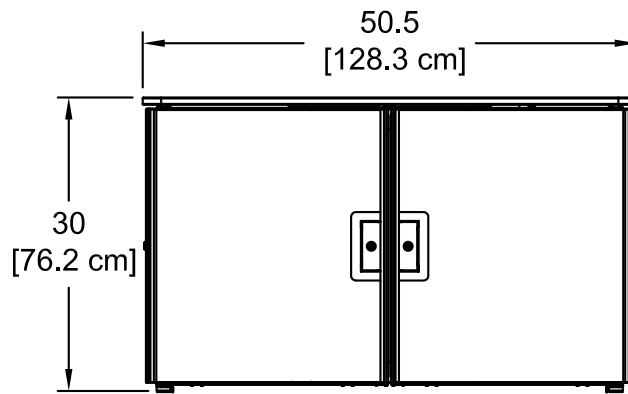
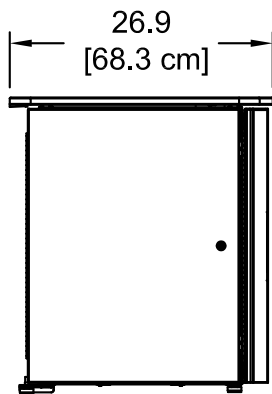
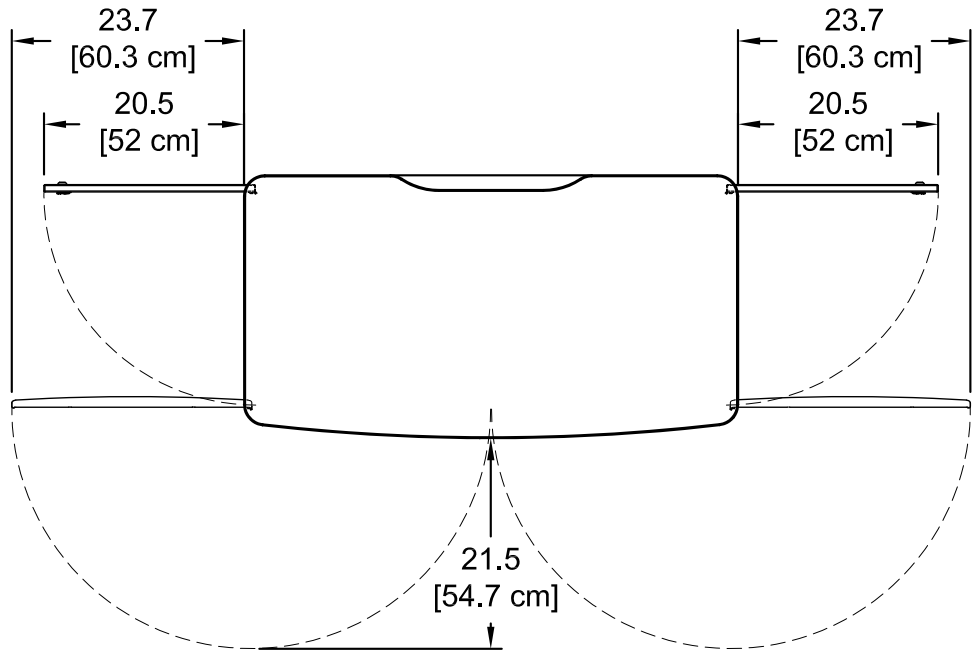
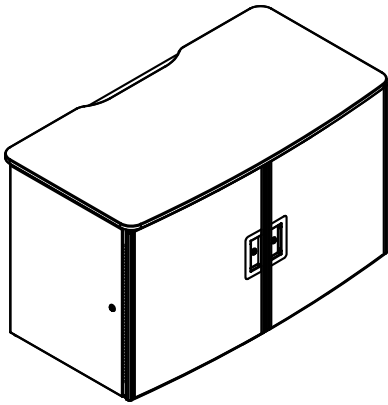

3-Bay AV Credenza
(shown with doors)

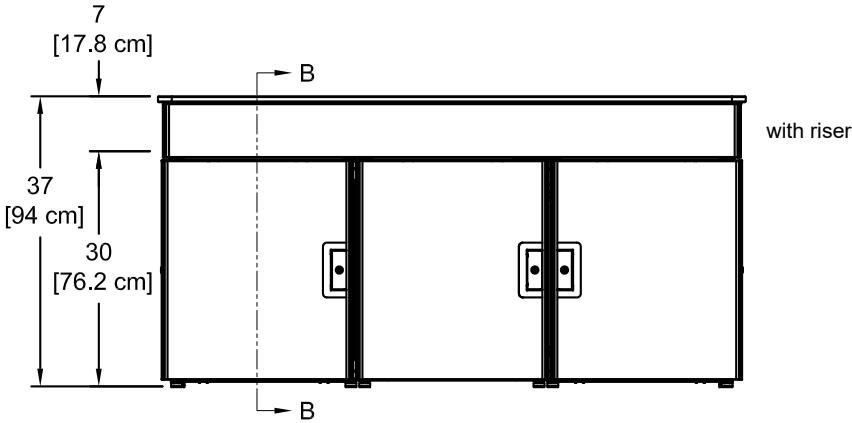
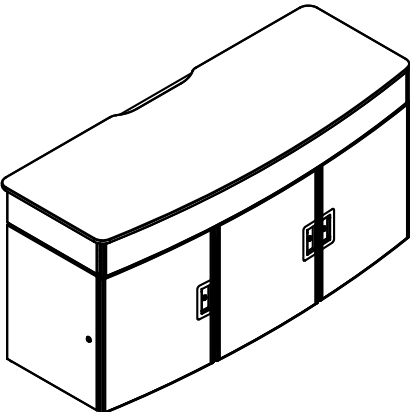
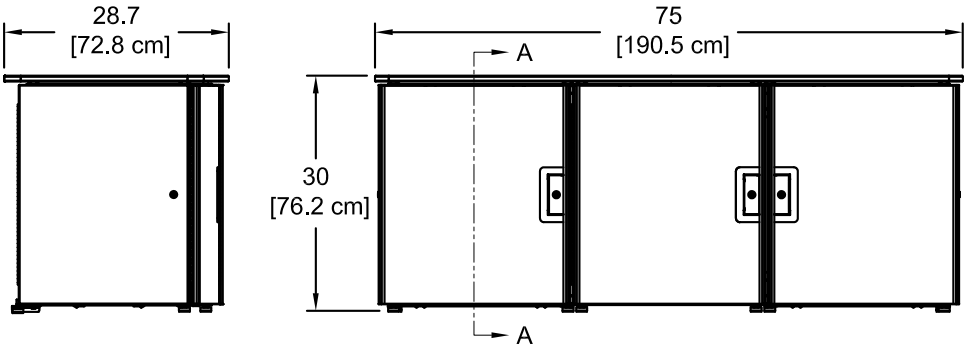
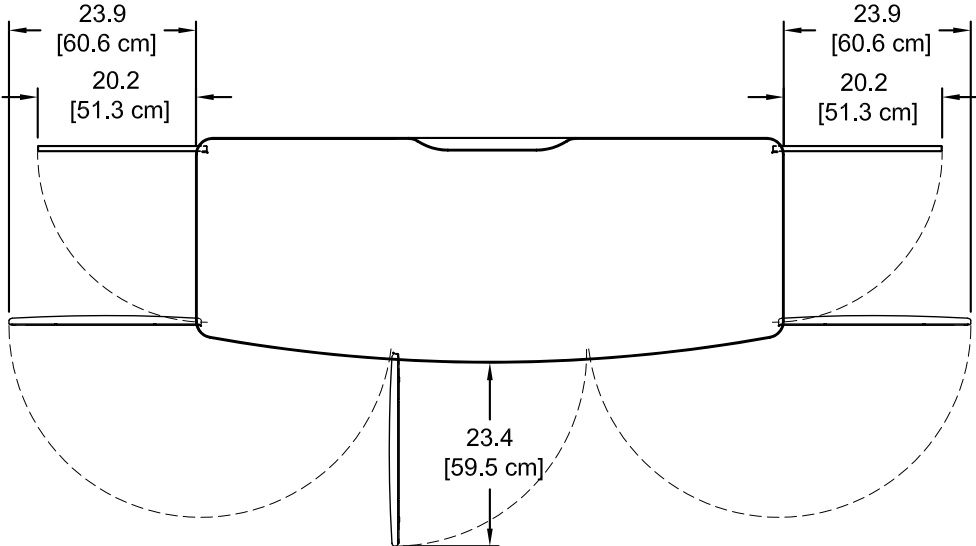
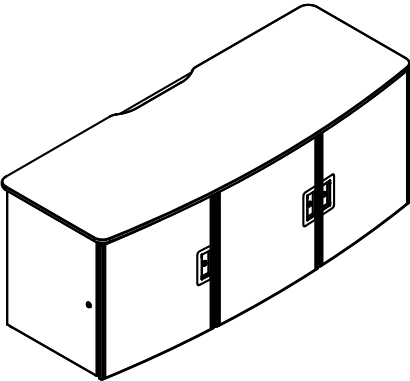

Section View A-A

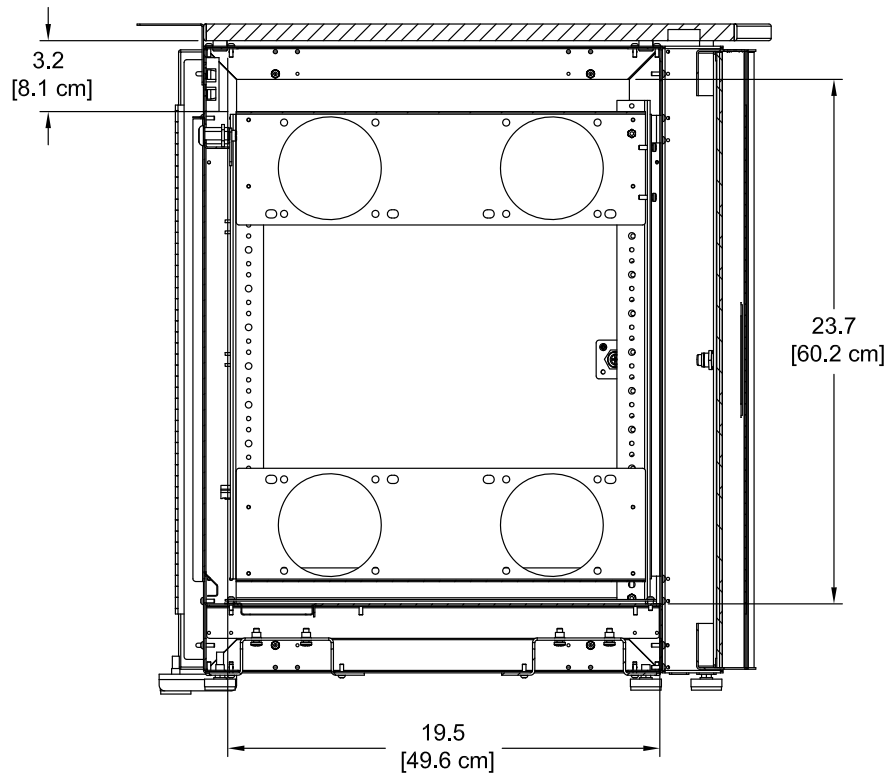

Section View B-B

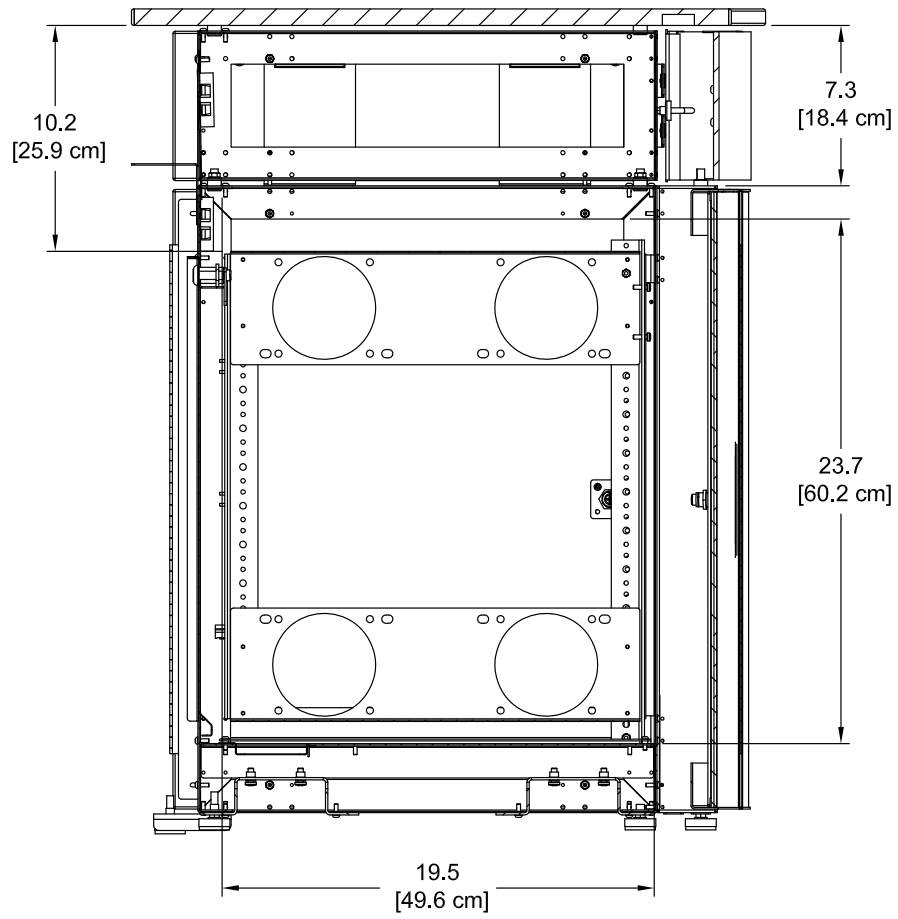

Worksurface cutout areas

Modified worksurface cutouts should be reviewed by Spectrum to ensure clearance of frame members, brackets, or other objects under the worksurface.

Max worksurface cutout areas
2-Bay worksurface
(Top View)

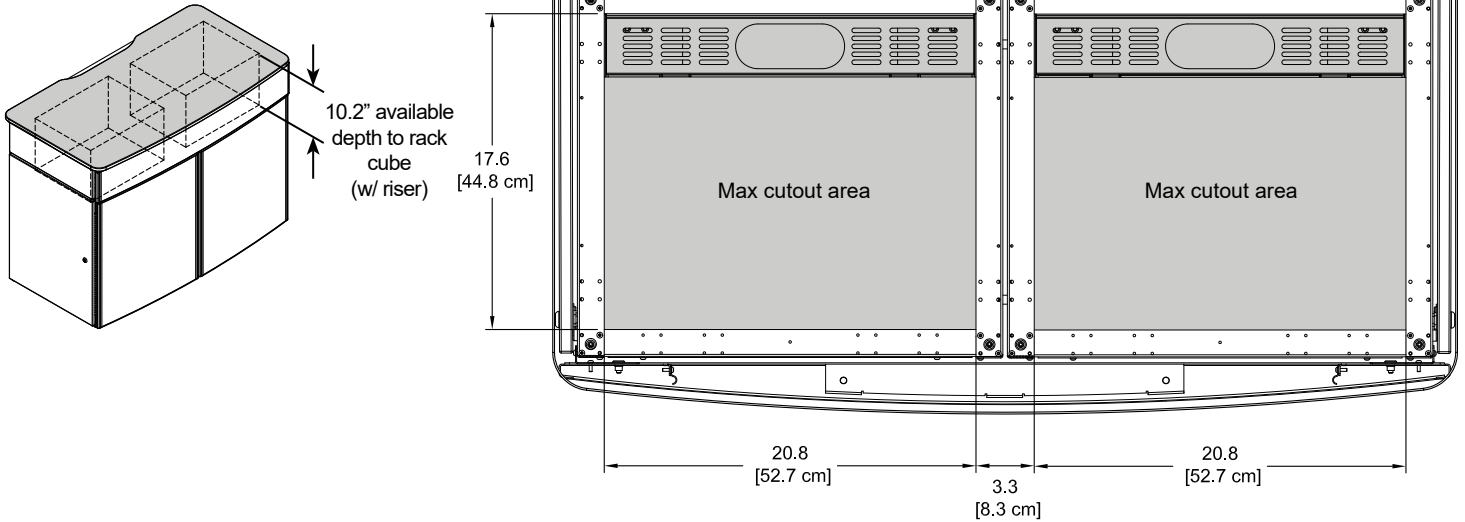

Max worksurface cutout areas
3-Bay worksurface
(Top View)

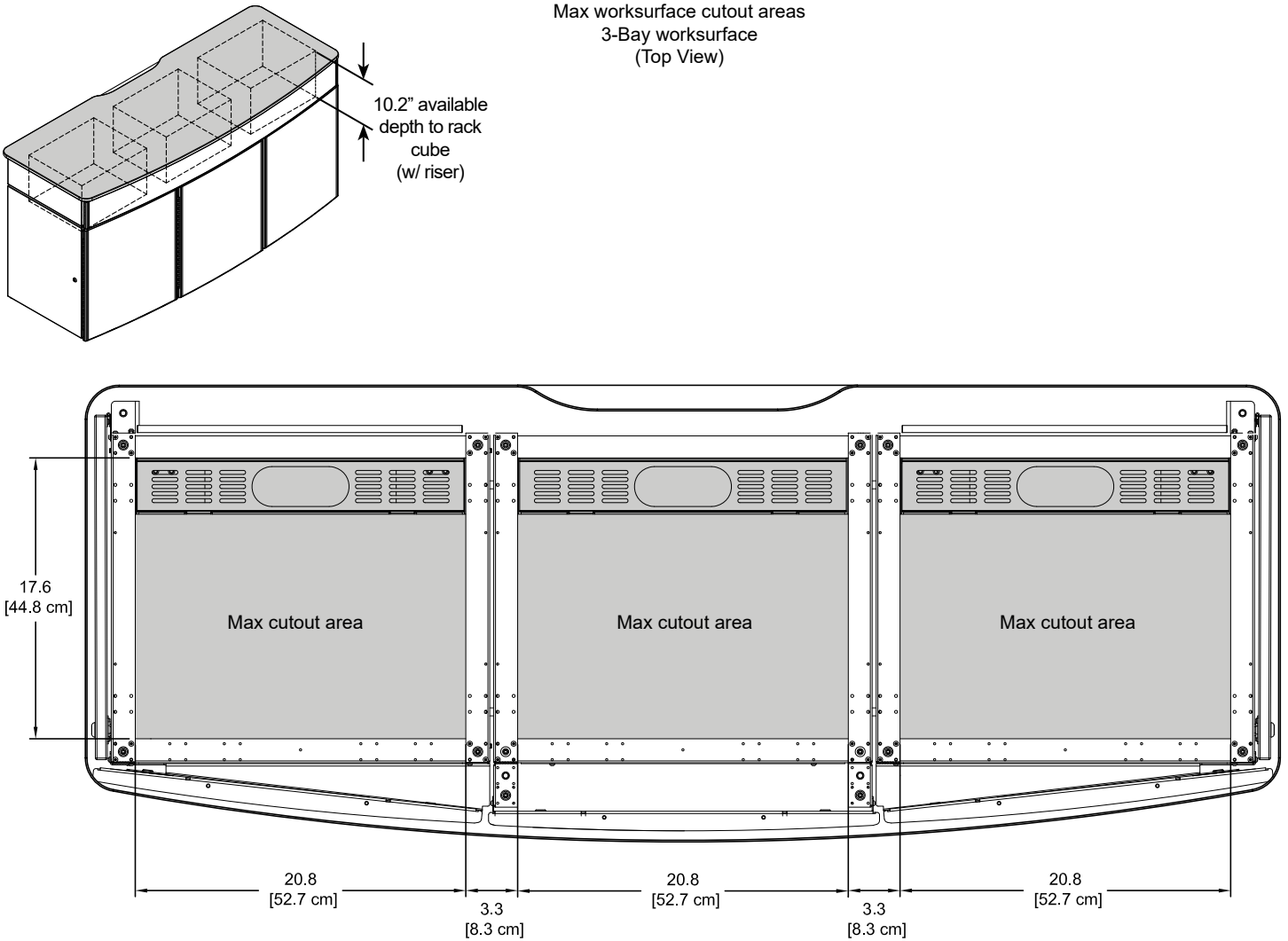

Front panel cutout areas

Modified front panel cutouts should be reviewed by Spectrum to ensure clearance of frame members, brackets, or other objects behind the panel.

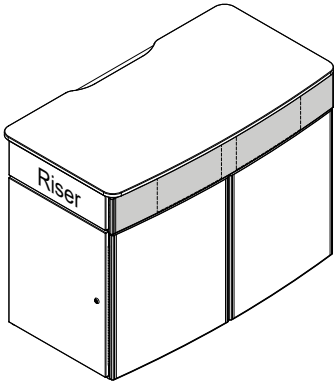

Max front panel cutout areas
2-Bay riser
(Front view)

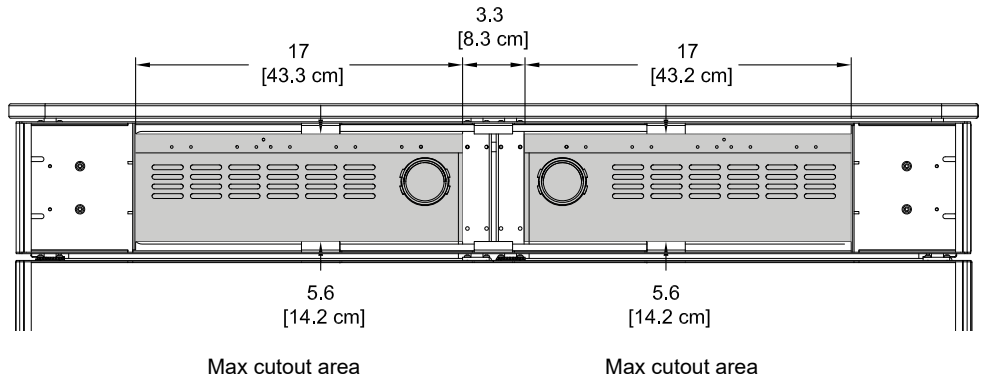

Max front panel cutout areas
3-Bay riser
(Front view)

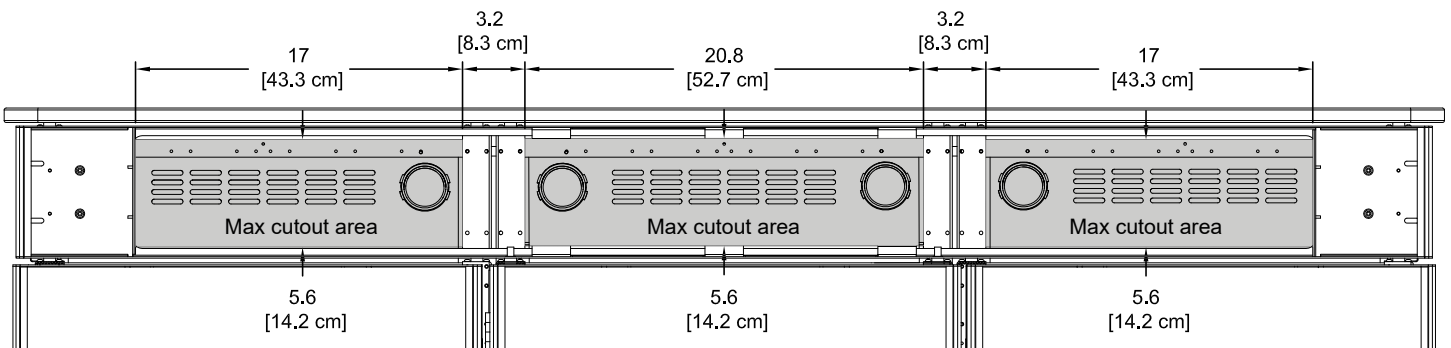
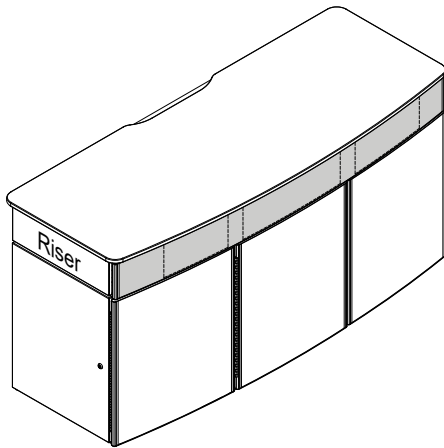

Accessories

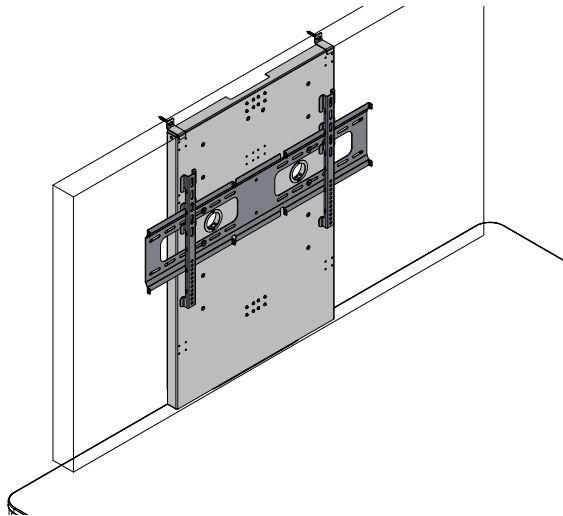

Display Stand - 55498

- Secured to worksurface and wall
- Cord grommets in wall panel route and hide wires
- Slim adjustable VESA mount (non-tilting)

Monitor size range:	37"-70" [94-177.8 cm] diagonal	
VESA compatibility:	200 x 200	600 x 400
	400 x 200	400 x 400
	300 x 300	800 x 400
Max monitor weight capacity:	125 lb [75 kg]	
Unit weight:	22.5 lb [10.2 kg]	

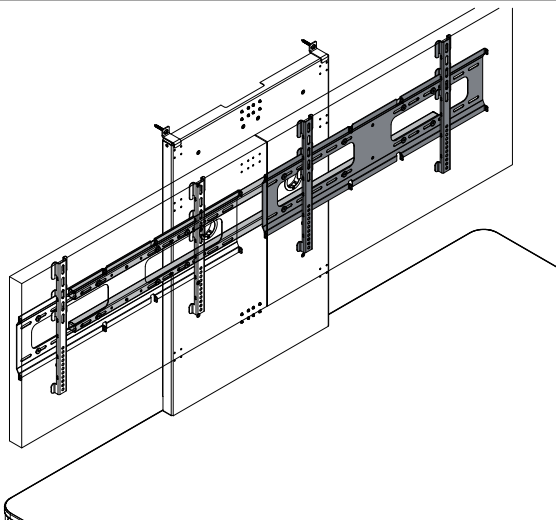

Dual Display Mount - 55499

- Accommodates two monitors up to 42" [106.7 cm]
- Includes (1) VESA display mount
- Includes (2) support tubes
- Adjustable left-to-right
- Requires Display Stand 55498

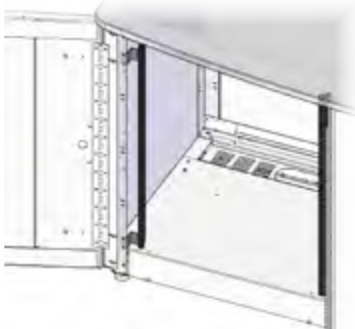

13RU Fixed Rack Rail - 55535

- Includes (2) 13RU rack rails
- Includes (4) mounting brackets
- Black powdercoat
- Shipping weight: 3 lb [1.4 kg]

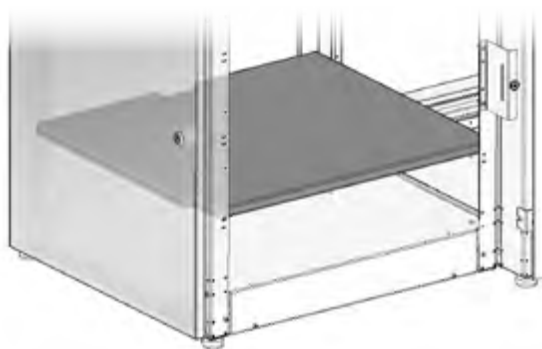

Adjustable Shelf - 55541

- 20.5"W [52 cm] x 23.5"D [59.7] x .75"H [1.9 cm]
- .75" thick MDF
- Customer-installed
- Shipping weight: 5 lb [2.3kg]



12RU Rack Cube - 55197

- Provides ability to integrate equipment remotely before installation into the unit
- (1) rack cube can be installed per bay
- Polyethylene slides on bottom for easy removal
- Requires 55534 bracket kit to secure to credenza
- Cooling fan compatible
- Black powdercoat
- Customer-installed

Rack rail:	12RU front and rear
Dimensions:	19.125"W [48.58 cm] x 19.031"D [48.34 cm] x 21.25"H [53.97 cm]
Mounts for cooling fans:	Compatible with most 4.7" fans with 4.13" mounting hole spacing (12 mounting locations available)
Steel	16ga
Unit weight:	21 lb [9.5 kg]
Shipping weight:	22 lb [10 kg]

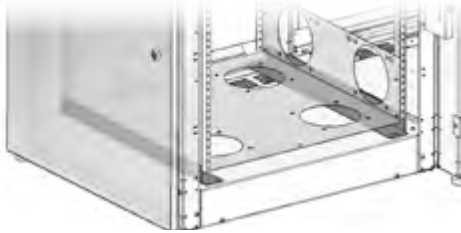

Bracket Kit for 55197 Rack Cube - 55534

- Secures the 55197 12RU Rack cube to base
- Elevates cube to provide additional ventilation or space to route wiring underneath
- Provides stability when rack-mount drawers are mounted in cube
- Black powdercoat
- Customer-installed
- Shipping weight: 5 lb [2.3kg]

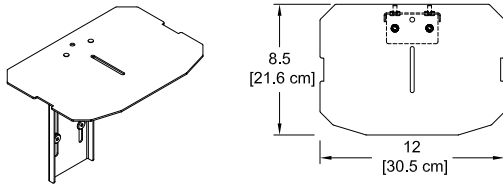

Camera Mount - 55518

- Provides ability to mount camera for video teleconferencing
- Requires optional Display Stand 55498, or 55499
- Mounts above monitor(s) for group teleconferencing
- Adjustable height shelf bracket provides ideal height
- Shipping weight: 5 lb [2.3kg]

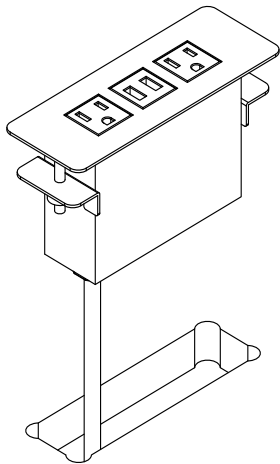

Power Module - 99058

- (2) AC power outlets
- (2) USB charge ports
- Aluminum housing and flange
- Thumbscrew clamps
- Requires worksurface cutout made by customer
- ETL-certified
- Available in black, silver, or white
- Customer-installed

Cutout required:	5.65"W [14.35 cm] x 1.65"D [4.19 cm]
Power cord:	10' [305 cm] 14AWG *3C power cord
Power receptacles:	125V, 60hz, 15A tamper-resistant
USB charging ports:	2.1A (10.5W) (not data-compatible)
Dimensions:	6.38"W [16.2 cm] x 2.36"D [6 cm] x 3.54"H [9 cm]
Unit weight:	2 lb [.9 kg]
Shipping weight:	2.35 lb [1 kg]



Product update
New USB-C Power Module version available. See details at:
www.spectrumfurniture.com

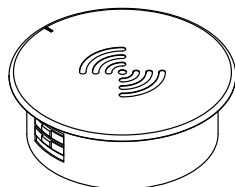

EM Wireless Charging Pad - 99057

- Uses electromagnetic technology to charge Qi V1.2 compliant IC devices ("Qi" enabled)
- LED to confirm pairing / charging
- Security tab prevents theft
- Requires 3" round cutout to be made by customer
- UL-certified

Cutout required:	3" dia (by customer)
Input:	DC 5V (with included DC5V.2A power adapter)
Output:	5W max (with included DC5V.2A power adapter)
Power cord:	8' [244 cm] with DC jack
Dimensions:	3.5" dia [8.9 cm] x 1.125"H [2.9 cm]
Shipping weight:	1 lb [.45 kg]

Note: The unit requires a 7" diameter of clearance to work with Qi-enabled phones placed in any orientation. The 3" dia cutout should be located on the worksurface at least 3.5" from any edge.

Rack-mount Accessories

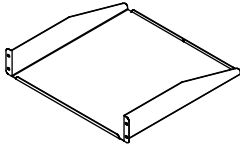

Cantilever Shelf - 2RU - 97504

- 16ga steel
- Shelf: 17.5"W [44.45 cm] x 18"D [45.7 cm] x 3.5"H [8.89 cm]
- Weight capacity: 50 lb [22.7 kg]
- Shipping weight: 8.1 lb [3.7 kg]

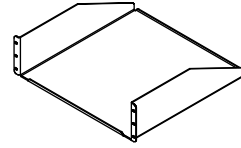

Cantilever Shelf - 3RU - 97502

- 16ga steel
- Shelf: 17.5"W [44.45 cm] x 18"D [45.7 cm] x 5.25"H [13.33 cm]
- Weight capacity: 80 lb [36.3 kg]
- Shipping weight: 9.2 lb [4.2 kg]

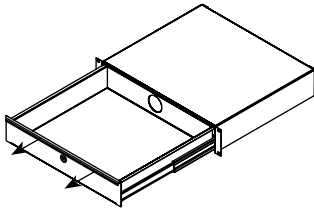

Locking Drawer - 2RU - 97527

- 16ga steel
- Drawer: 15.97"W [40.56 cm] x 14.56"D [36.98 cm] x 3"H [7.63 cm]
- Weight capacity: 50 lb [22.7 kg]
- Shipping weight: 15.85 lb [7.2 kg]

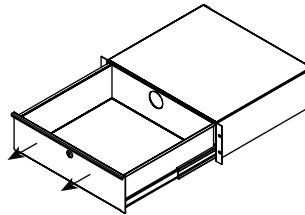

Locking Drawer - 3RU - 97526

- 16ga steel
- Drawer: 15.97"W [40.56 cm] x 14.56"D [36.98 cm] x 5.25"H [13.33 cm]
- Weight capacity: 50 lb [22.7 kg]
- Shipping weight: 18.5 lb [8.4 kg]
- Shipping weight: 8.1 lb [3.7 kg]

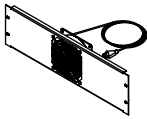

Single Fan - 3RU - 97507

- 50 cfm
- 120V~50/60 Hz, 15/13W
- RoHS
- 19"W [48.27 cm] x 1.56"D [3.97 cm] x 5.25"H [13.33 cm]
- Shipping weight: 3.78 lb [1.7 kg]

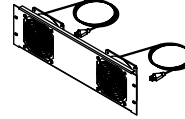

Double Fan - 3RU - 97506

- 100 cfm
- 120V~50/60 Hz, 15/13W
- RoHS
- 19"W [48.27 cm] x 1.56"D [3.97 cm] x 5.25"H [13.33 cm]
- Shipping weight: 5.47 lb [2.5 kg]

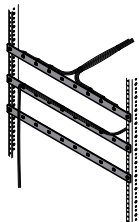

Wire Lace Kit - 95517

- Provides wire management
- Mounts to standard rack rails
- Includes (3) lace straps and mounting screws
- Includes (12) 5.5" zip ties
- Shipping weight: 1.25 lb [.57 kg]

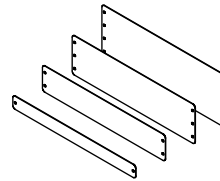

Rack-Mount Blanks

1RU - 97510 3RU - 97512
2RU - 97511 4RU - 97513

- Fills rack spaces where components are not needed
- 16 ga steel
- Shipping weight: <1 lb [.45 kg]

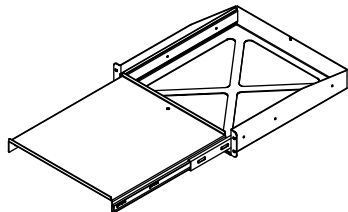

Pull-Out Shelf - 2RU - 97505

- 16ga steel
- 17.09"W [43.42 cm] x 18.12"D [46.03 cm] x 3.5"H [8.89 cm]
- Weight capacity: 50 lb [22.7 kg]
- Shipping weight: 15.6 lb [7.1 kg]

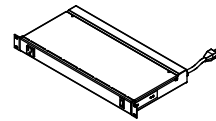

9-Outlet Power Strip - 1RU - 99021

- 8 outlets rear (breaker-protected)
- 1 convenience outlet front
- 115VAC, 60 Hz, 15 amps max
- 9' power cord
- Front LED power switch
- Enhanced surge protection
- ETL-listed, UL-listed
- 19"W [48.27 cm] x 9.25"D [23.5 cm] x 1.74"H [4.41 cm]
- Shipping weight: 8.7 lb [3.9 kg]



See spectrumfurniture.com for the latest accessories and detailed warranty information.

Warranty

We will make it right for you!

Thanks for choosing Spectrum! Spectrum is committed to provide complete customer satisfaction. Each of our products is manufactured from the best materials available and each product is stringently monitored throughout the production process through our P.A.C.E. program (Product Assurance to meet Customer Expectations).

We expressly warrant that Spectrum products will be of good quality and workmanship and free from defect for the period set out in the warranty from the date of delivery.

For a listing of all product specific warranty terms please visit our website at:

<https://www.spectrumfurniture.com/en/resources/purchasing-terms-warranty>

1-800-235-1262

Toll-free HELPLINE

spectrum@spectrumfurniture.com