

Assembly Instructions

⚠ Important ⚠

Before you begin, read and comply with all safety and operating instructions, and ensure all parts and correct quantities are included.

Any parts damaged during shipment must be reported within 5 days of receipt. To report information regarding missing parts or damage, to purchase parts or accessories, or if you have any questions, please contact us.

www.spectrumfurniture.com
800-235-1262, 715-723-6750

Thank you for purchasing Spectrum products!

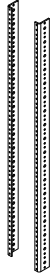

(2) 0100437
24.5" Rails (for 29"H Rack)
or
(2) 0108668
31.5" Rails (for 36"H Rack)



(8) 0100167
8-32 x 1/2" PH
Thread-cutting screw

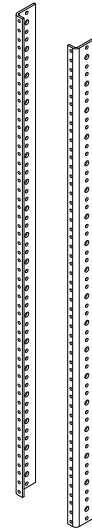

Rear Rack Rail for IMC Eq Rack

68100 - 29"H (14RU)
68150 - 36"H (18RU)



Installation

1. Open the rear equipment rack door.
2. Align each rack rail with the pre-drilled equipment rack mounting holes. **Figure 1.** Be sure the short leg on each rail points inward as shown.
3. Attach each rail to the equipment rack frame with (4) 8-32 x 1/2" PH thread-cutting screws, while making sure the screws are installed straight. (Start screws by hand).
4. Do not tighten completely until all screws are installed. If using an electric drill, make sure the torque is on a low setting so the screw threads do not strip out.

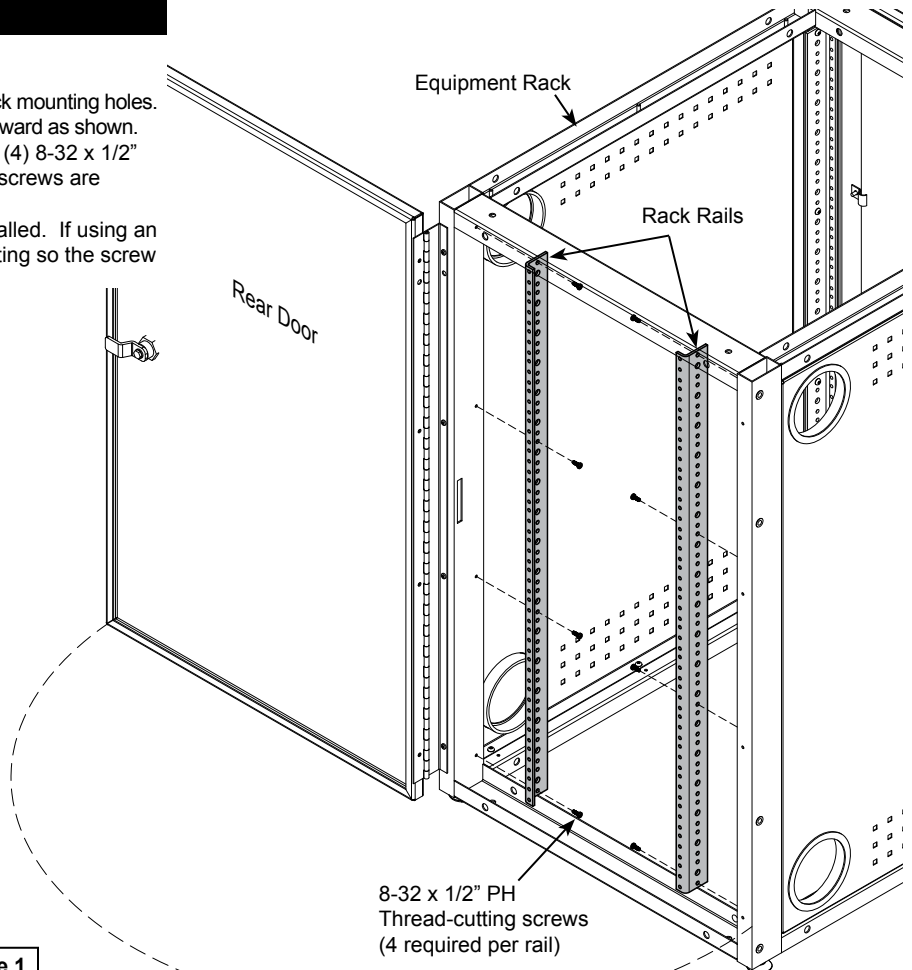

Figure 1