

Technical Specifications

55470

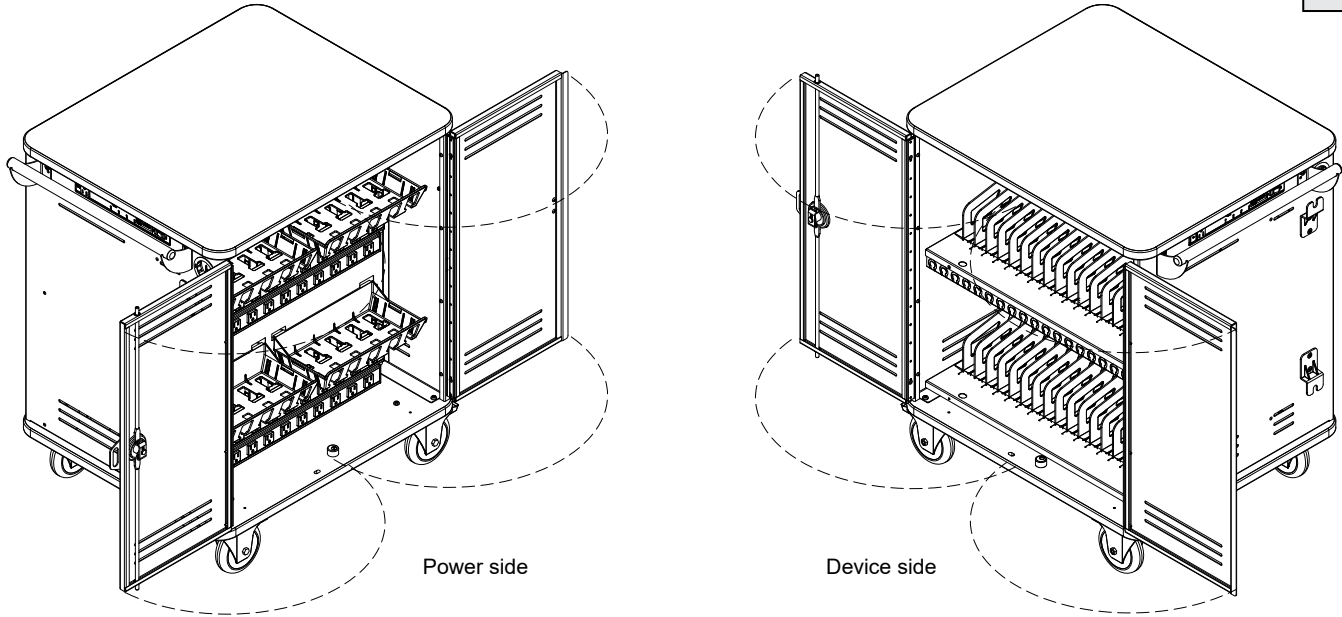

Use the Cloud40 cart to store, transport, and charge up to 40 of the largest devices. The cart's compact footprint (30.75" x 26") allows easy movement between rooms and saves valuable space. A current-sensing timer provides adaptive switching, preventing electrical overload in underpowered classrooms, and will handle the next generation of devices with high wattage charge adapters. Padded shelves and flexible dividers protect the devices. Overhead wire management aids the wiring integration and allows the charging plugs to hang in front of each device. The cart's compact footprint and handle provide easy mobility. The Cloud40 Cart is made with heavy-gauge steel for security and powder-coated for a durable, long-lasting finish. A dual-bolt lock with hasp on the doors increase security of the devices.



Features and Benefits

- Stores, charges, and transports up to 40 of the largest devices (up to 14")
- 1.25"W x 15.3"D x 12.3438"H storage bay
- Small cart footprint (30.75"W x 26"D) saves valuable space
- Durable ABS plastic dividers protect devices from scratching (dividers are removable to provide storage space for thicker devices)
- Dual doors provide easy access while reducing space necessary for swing radius
- Double bolt keyed locks and heavy-gauge steel doors provide security
- Hasp locks provide an additional level of security and the ability to use your padlocks of choice (not included), or secure the unit to a wall
- Devices and students are separated from all line voltage
- Superior, all-metal overhead cord management system keeps charge cords organized above each storage bay
- Large, removable QuickBrick™ wiring trays with retaining straps for charge adapters allow wiring to be completed outside the cart at the comfort of a workstation or desk to provide quick and easy integration
- Ventilated doors and side panels keep devices and chargers cool, preventing overheating, and extending device life
- Replaceable, IEC quick-release, 8' nominal 14 AWG, 3-wire power cord and external cord wrap brackets provide easy power access
- Four inboard locking 5" balloon wheel casters provide easy rolling, and quiet transport
- One all steel handle provides control and maneuverability
- Worksurface and base panel vinyl edging protects walls and furniture
- Cart ships fully-assembled with handle for quick, simple integration and deployment
- Durable powder coated steel chassis provides a long-lasting finish
- Scratch and impact-resistant high-pressure laminate top provides a durable, useful worksurface for instructors
- ETL certified to UL 60950-1 in the US and Canada for the cart and electrical system
- Warranted to be free of all defects in materials and workmanship for 10 years, electrical system 2 years
- Designed and assembled in Chippewa Falls, WI, USA
- Intuitive PowerProdigy™ charging system senses current from up to four, 10-outlet power units and distributes power (up to 10A) to the least-charged devices first (where charging is needed most)
- ***For most power adapters up to 135W**
- Four adjustable, 10-outlet, (125V~/12A, 60Hz) universal power units work with both inline, and wall adapters
- External power switch provides easy-access for safe power connection / disconnection
- 2 auxiliary outlets (always on) for teacher laptop, Wi-Fi access point, or other accessory (1 external, 1 internal)
- Cart is available prewired with USB-C PD chargers

Note: This cart is designed to hold up to 40 devices.

55470-ABD - Cloud40 w/ PowerProdigy™ timer
55470-USBC - Cloud40 w/ USB-C PD charging / PowerProdigy™ timer (prewired)

Color Options

Laminate:
White Fiesta



Metal:
Warm Gray

Construction

- The worksurface and base panel is constructed from 1" composite board with .030" high-pressure laminate on one face, and a balancing phenolic backer on the opposing face
- Worksurface and base panel edges are covered with 3mm vinyl edge band
- 16-gauge side panels, shelves, and doors
- All metal components are finished with a scratch-resistant powder coat epoxy
- This cart is factory-assembled, packaged, and shipped on its own skid

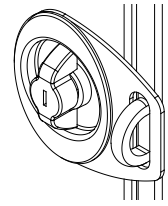

Double-bolt lock with padlock hasp (on both doors)
(padlocks not included)

Specifications

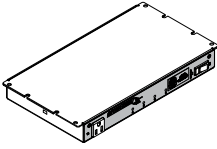
Capacity	40 devices	
Storage bays (nominal)	1.25"W [3.18 cm] x 15.3"D [38.89 cm] x 12.3438"H [31.36 cm]	
Electrical	<ul style="list-style-type: none"> • (4) 10-outlet power units (outlets rotated 90°) • 125V~/12A, 60Hz • 15-amp breaker 	<ul style="list-style-type: none"> • Locking power-side door isolates and separates electrical line voltage from students • ETL recognized (certified to 60950-1)
PowerProdigy™ Timer	 <ul style="list-style-type: none"> • Low-profile, 16-gauge steel enclosure • 125V~/12A, 60Hz • Externally-accessible 15A on/off switch • Smart charging senses current and distributes power to the power units requiring it most • Four timed power unit-dedicated outlets (labeled A, B, C, D) controlled by logic board (up to 10A power output) 	<ul style="list-style-type: none"> • Cycling interval 15 min • Four LED lights indicate charging activity status of each power unit • Two auxiliary outlets (1 external, 1 internal) 1A each (controlled by main on/off switch) • IEC quick-release (replaceable) 8' nominal, 14 AWG, 3-wire power cord • ETL recognized (certified to 60950-1)
<p>⚠ Note: The customer should be aware of the amp draw of the devices used with this cart-especially when maxing out the storage and charging capacity. Exceeding 15 amps will trip the circuit breaker. Please consult the owners manual of your specific device for power consumption information.</p>		
5" Balloon Wheels	Weight capacity 300 lb [136 kg] each	
Certifications / Compliance	<ul style="list-style-type: none"> • ETL certified to UL 60950-1 	<ul style="list-style-type: none"> • Meets or exceeds applicable ANSI-BIFMA test standards
Unit weight (nominal)	208 lb [94.4 kg]	
Shipping weight (nominal)	240 lb [108.9 kg]	

Specifications subject to change without notice

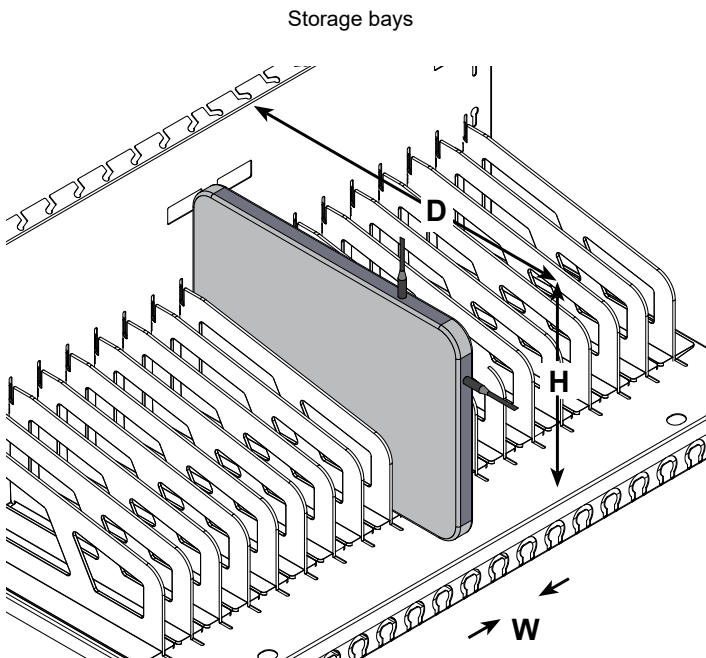

Devices must be placed in the bays with the charge plug on one of the two exposed edges shown.

Note: Do not place items weighing more than 50 lb [22.7 kg] on the top surface. Please remove or secure items before moving cart.

USB-C PD Charger
(USB-C PD prewired cart only)



Specifications:

- Model: HA712
- Input: 100-240V ~ 50/60Hz 1.5A
- Output (USB-C PD): 5V~3A, 9V~3A, 12V~3A, 15V~3A, 20V~3.25A
- Dimensions: 1.97" x 1.97" x 1.10" (50mm x 50mm x 28mm)
- Net Weight: 3.42 oz [97 g]

5" Balloon Wheel

Note: (2) locking, and (2) non-locking casters are included on each cart.

External power switch, LED indicators, and AUX outlet

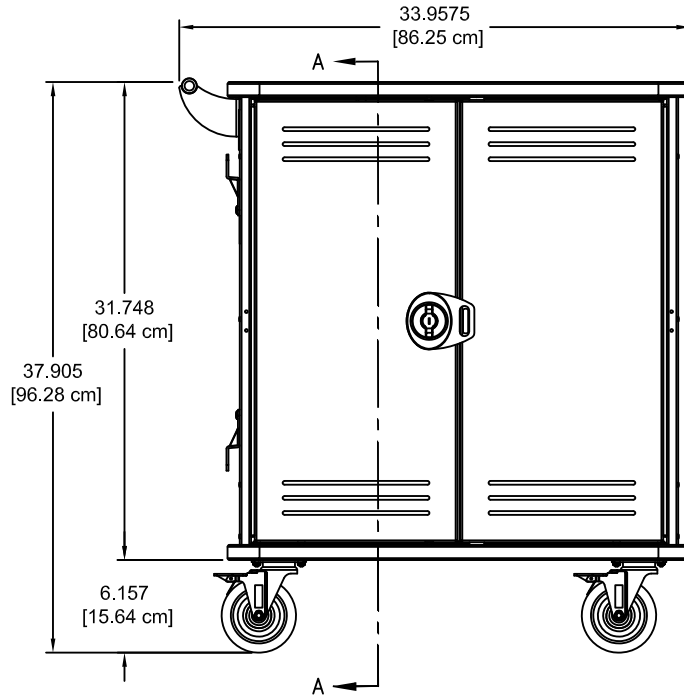
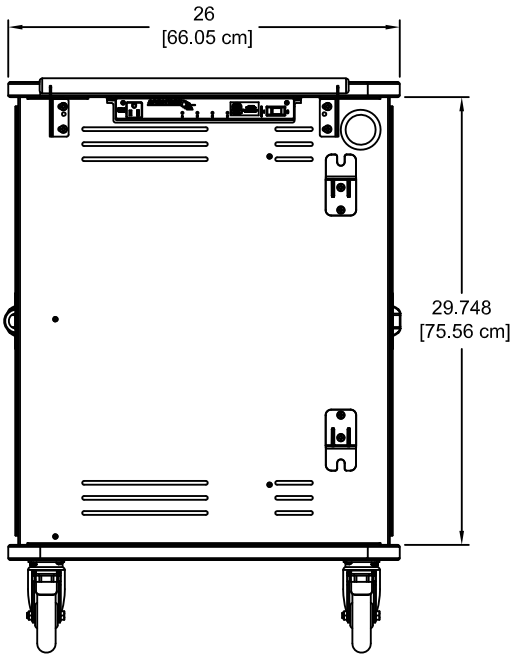
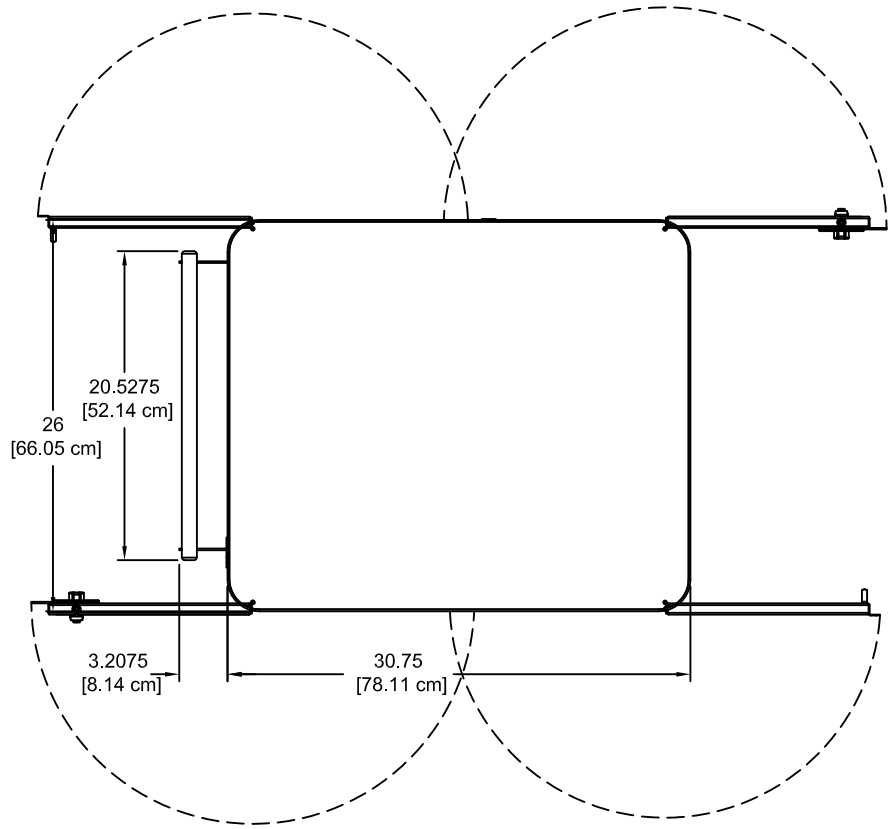
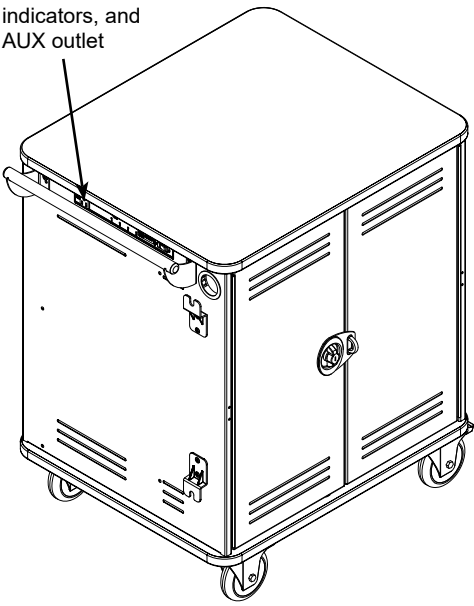

Section view A-A
(shown with common Chromebook models)

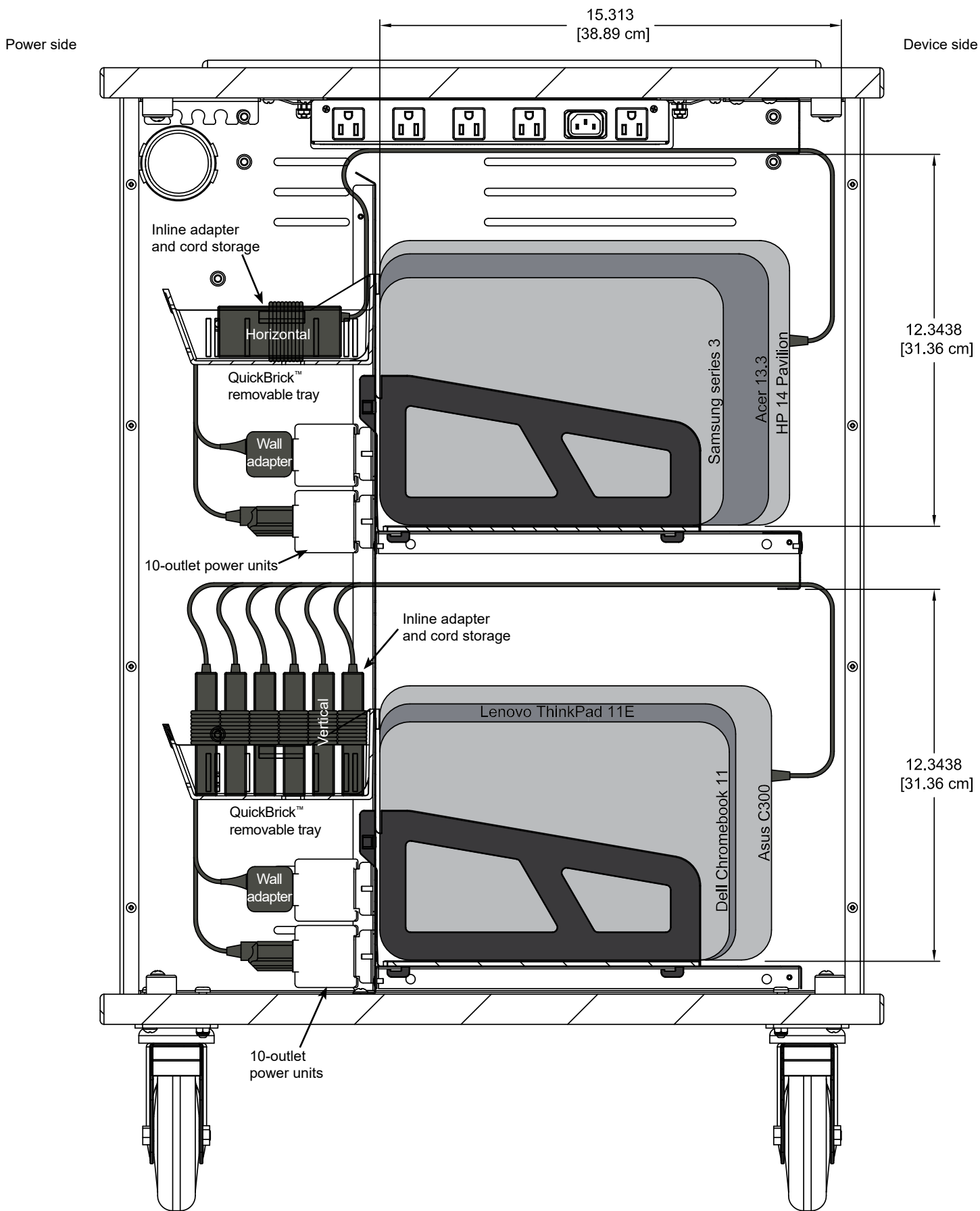

Device side view wiring diagram
(shown without door)

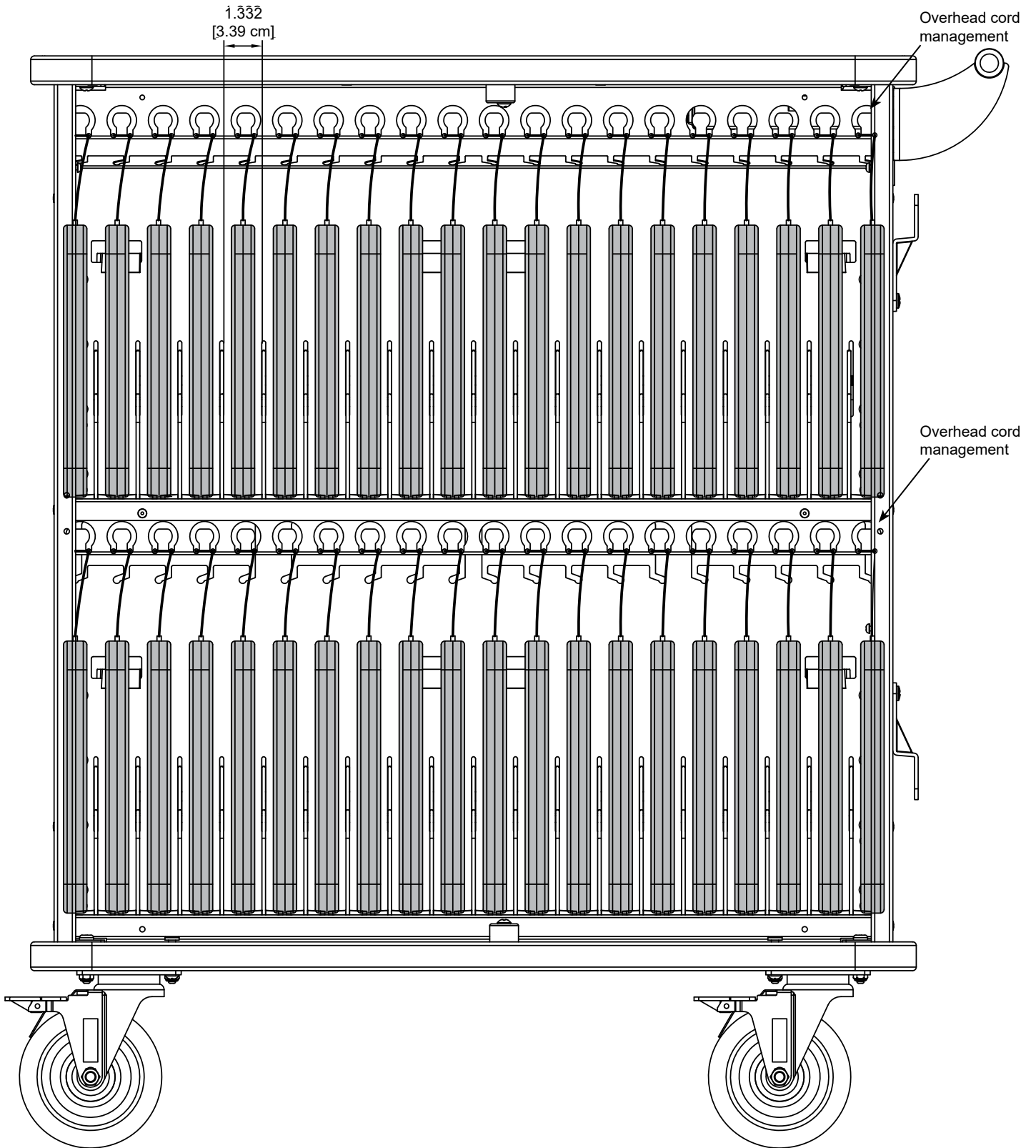

Power side wiring diagram
(shown without door)

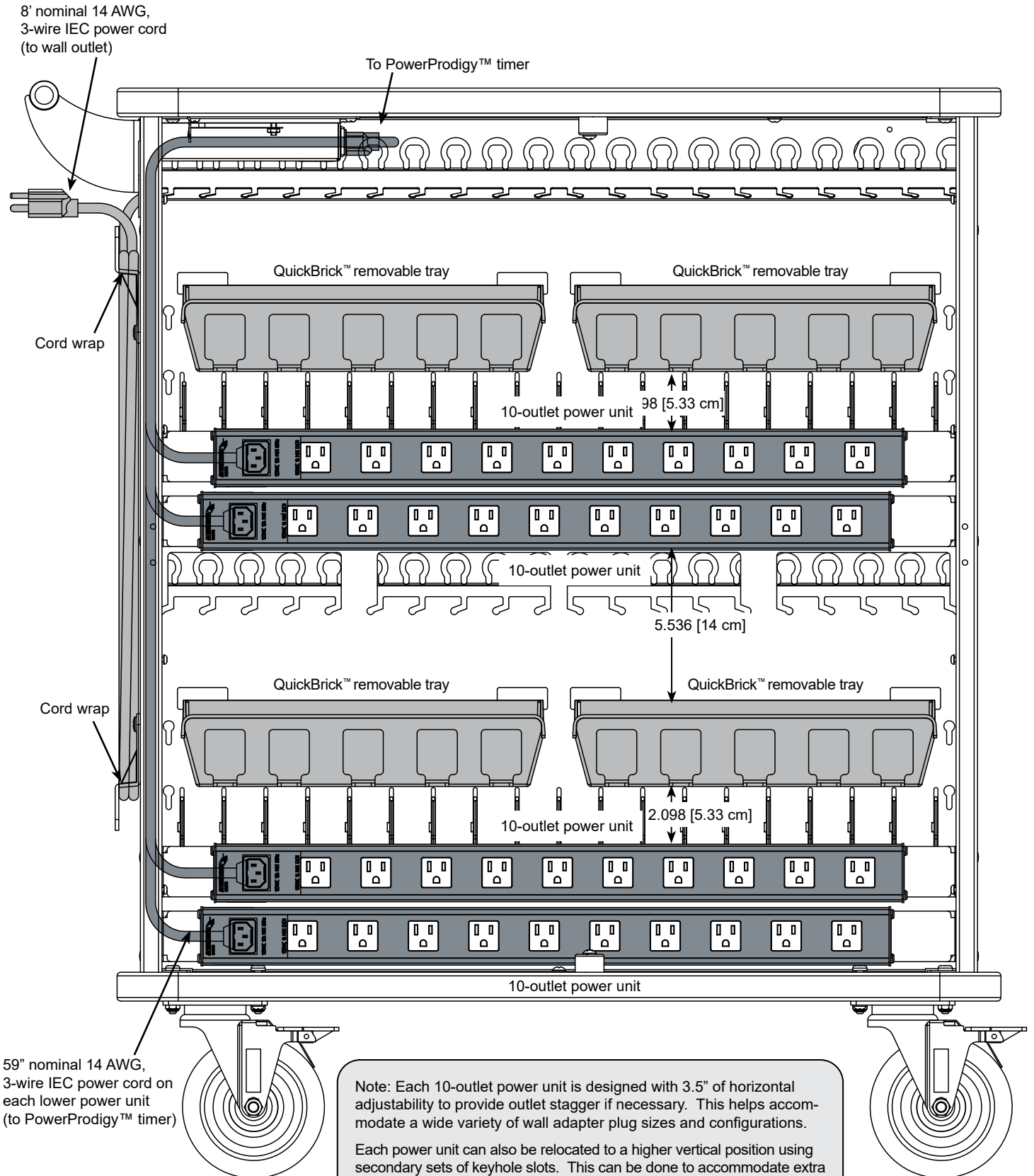

Note: Each 10-outlet power unit is designed with 3.5" of horizontal adjustability to provide outlet stagger if necessary. This helps accommodate a wide variety of wall adapter plug sizes and configurations.

Each power unit can also be relocated to a higher vertical position using secondary sets of keyhole slots. This can be done to accommodate extra large wall adapters. The QuickBrick™ trays have to be removed in this configuration.

PowerProdigy™ Timer

**Use with higher amp-draw devices.
Maximum charging capacity: 5,760 watts.**

- Smart charging senses current and distributes power to the power units requiring it most
- Four green LED lights indicate charging activity status of each power unit
- Four timed power unit-dedicated outlets (labeled A, B, C, D) controlled by logic board
- Two auxiliary outlets (1 external, 1 internal)
- ETL recognized (certified to 60950-1)

Input:	125V~/12A, 60Hz
Breaker:	15A, 250 VAC
Cycling interval:	15 minutes
Cycling outlets:	4 timed (A, B, C, D) up to 10A
Auxiliary outlets:	1A each (controlled by main power switch)
Power Cord:	IEC quick-release (replaceable) 8' nominal, 14 AWG, 3-wire
Power switch:	15A (externally accessible)

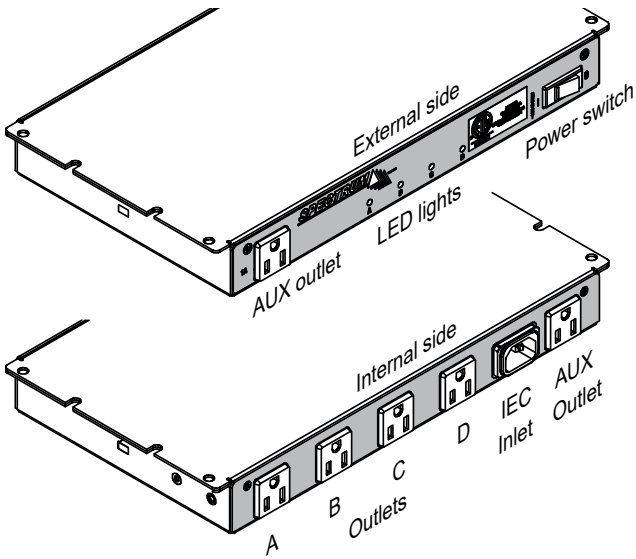

Total watts required per cart (estimated) = Number of devices X Charger wattage

Power unit adjustability

Note: Each 10-outlet power unit is designed with 3.5" of horizontal adjustability to provide outlet stagger if necessary. This helps accommodate a wide variety of wall adapter plug sizes and configurations.

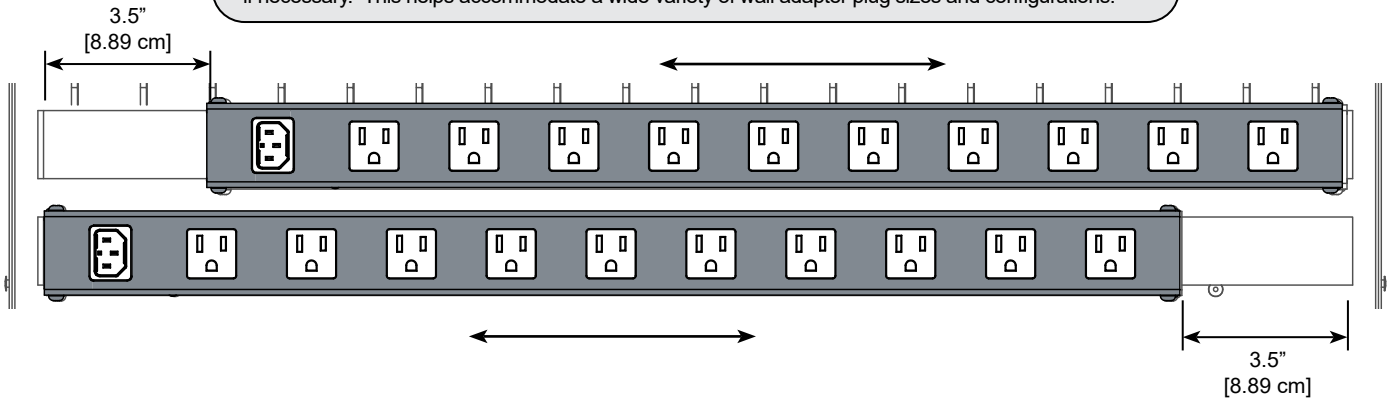

Nominal outlet spacing on each 10-outlet power unit

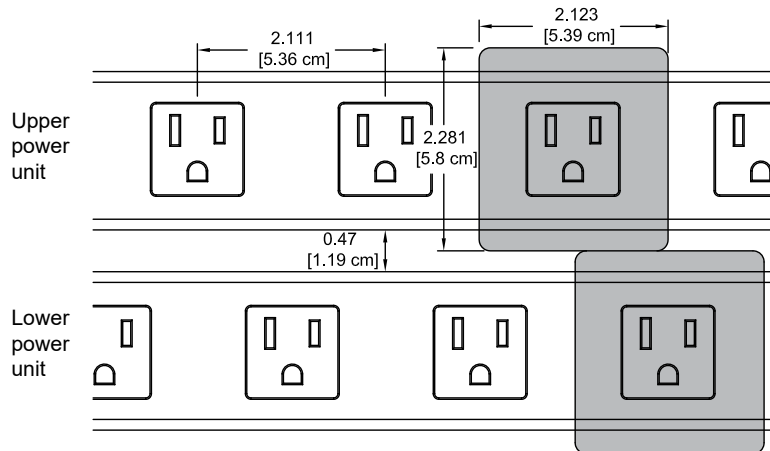

(See p.7 for spacing above and below outlets)

Power unit vertical adjustability
(shown without door)

Note: Four sets of keyhole slots provide the ability to vertically relocate each 10-outlet power unit. This can be done to provide clearance for extra large wall adapters. Loosening two screws on each power unit allows easy adjustment. The QuickBrick™ trays are not needed and have to be removed in this configuration.

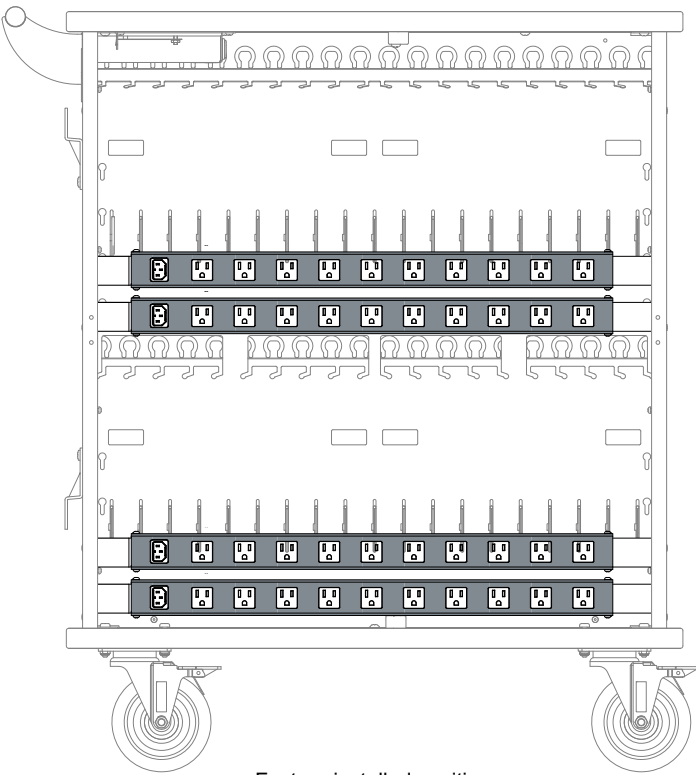
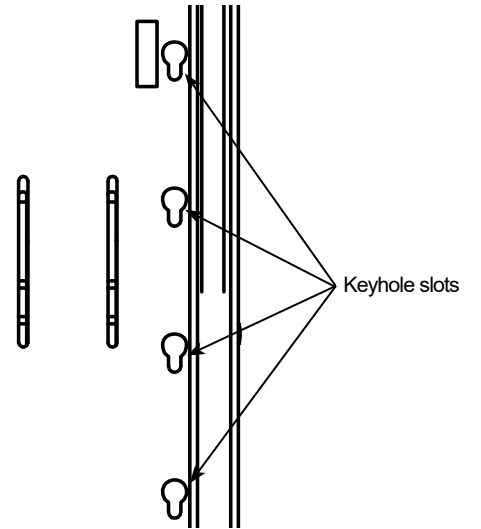

Factory-installed position

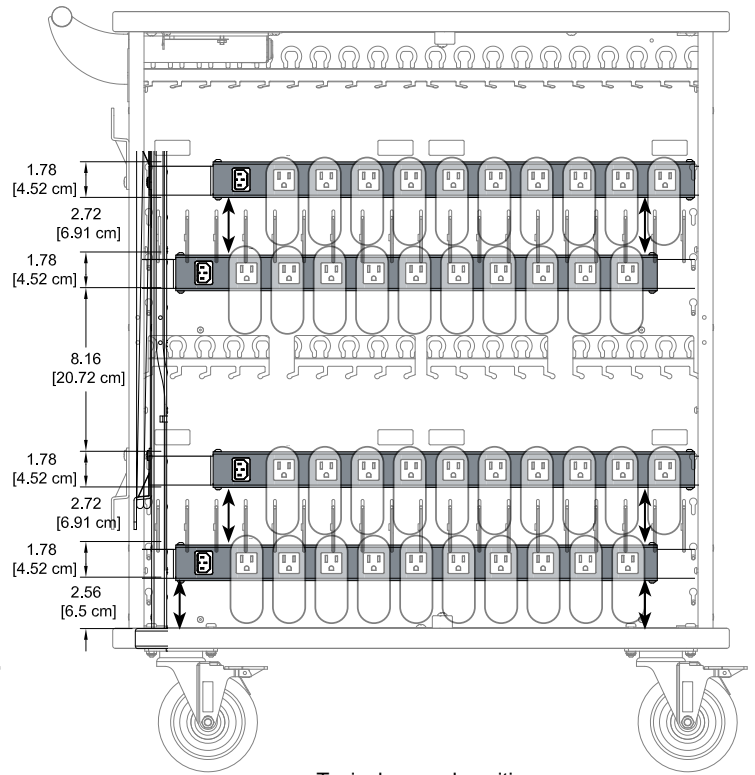

Typical spaced positions
for large wall adapters

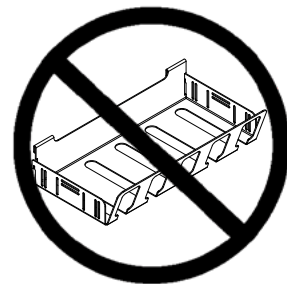
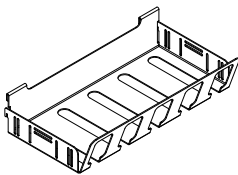

Note: Cart includes four QuickBrick™ removable trays with a hook and loop retaining strap for charge adapters to provide fast and easy wiring for quick deployment.

For devices with wall adapters, the QuickBrick™ removable trays can be used to store bundled cords.

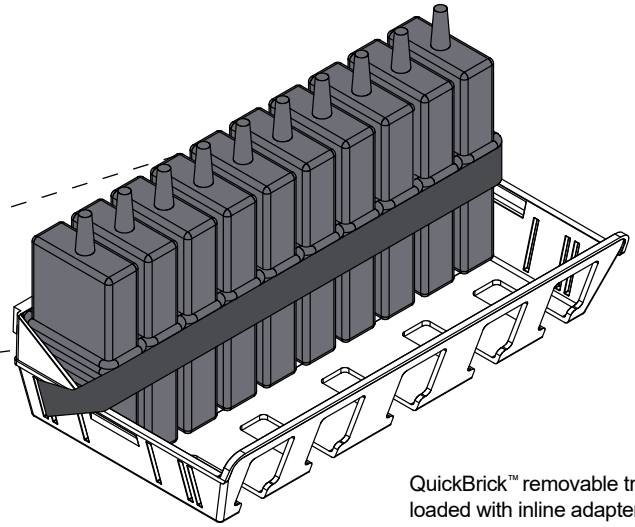
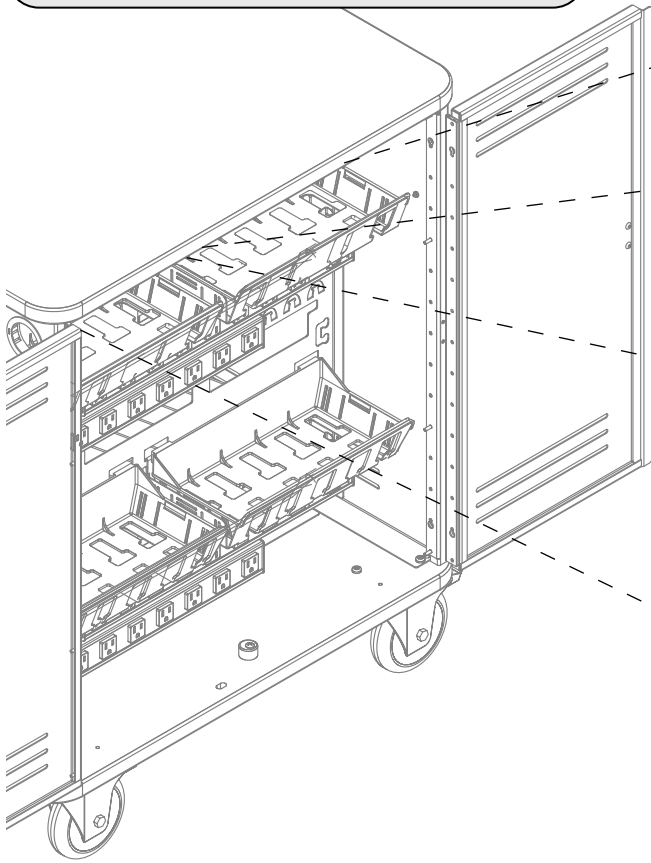

QuickBrick™ removable tray loaded with inline adapters in vertical position

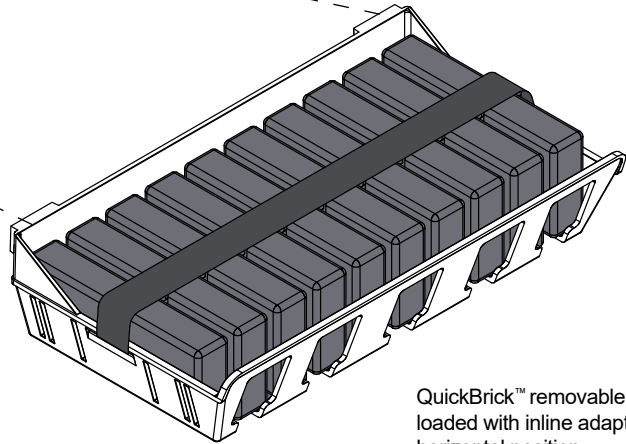

QuickBrick™ removable tray loaded with inline adapters in horizontal position

Accessories

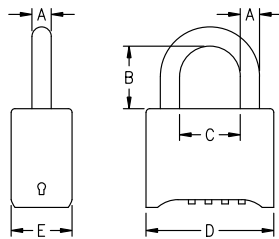

A	.3125" [7.9 mm]
B	1" [25.4 mm]
C	.983" [25 mm]
D	2.07" [52.5 mm]
E	.987" [25.1 mm]

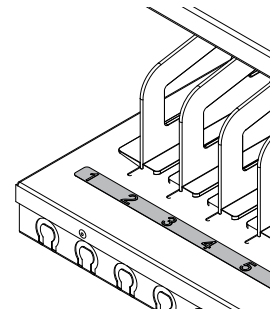

Re-programmable 4-digit Combination Lock - 95536

- Set your own 4-digit personalized combination (up to 10,000 options)
- 5/16" hardened steel shackle for cut-resistance
- Black powdercoated die-cast body for durability
- Change key included
- Unit weight: .55 lb [.25 kg]

Hook-and-loop Strap Kit - 95004

(16) .75" [1.91 cm] x 12" [30.48 cm], and (32) .75" [1.91 cm] x 5" [12.7 cm]

Slot labels for Cloud40 - 55475

- Black numbers on transparent adhesive backer
- 1-20 label, 21-40 label

See [spectrumfurniture.com](https://www.spectrumfurniture.com) for the latest accessories and detailed warranty information.

Warranty

We will make it right for you!

Thanks for choosing Spectrum! Spectrum is committed to provide complete customer satisfaction. Each of our products is manufactured from the best materials available and each product is stringently monitored throughout the production process through our P.A.C.E. program (Product Assurance to meet Customer Expectations).

We expressly warrant that Spectrum products will be of good quality and workmanship and free from defect for the period set out in the warranty from the date of delivery.

For a listing of all product specific warranty terms please visit our website at:

<https://www.spectrumfurniture.com/en/resources/purchasing-terms-warranty>

1-800-235-1262

Toll-free HELPLINE

spectrum@spectrumfurniture.com