

Assembly Instructions

⚠ Important ⚠

Before you begin, read and comply with all safety and operating instructions, and ensure all parts and correct quantities are included.

Any parts damaged during shipment must be reported within 5 days of receipt. To report information regarding missing parts or damage, to purchase parts or accessories, or if you have any questions, please contact us.

www.spectrumfurniture.com
800-235-1262, 715-723-6750

Thank you for purchasing Spectrum products!

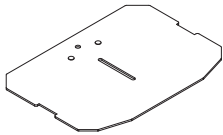

(1) 0102394
Shelf Assembly



(2) 052605
1/4-20 x 15mm JC bolt



(2) 0106543
1/4-20 Keps nut

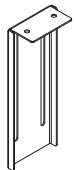

(1) 0144920
Shelf Bracket



(2) 026059
1/4" Washer

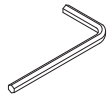

(2) 025039
4mm Hex wrench

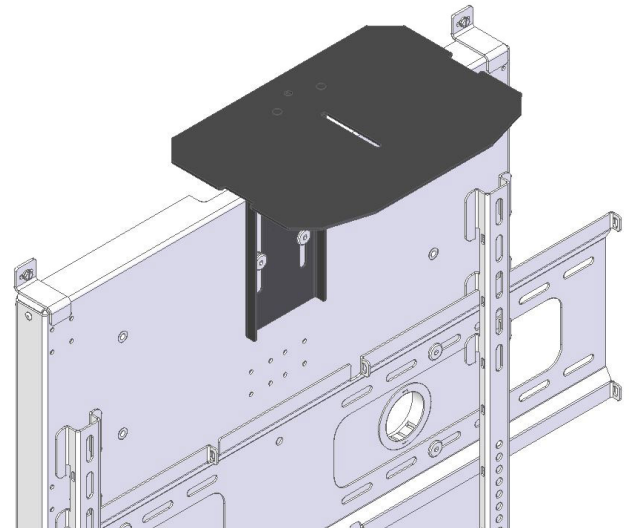

Camera Mount 55518

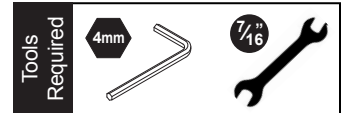

1. Assemble mount

1. Attach the shelf to the bracket with (2) 1/4-20 Keps nuts and tighten securely. **Figure 1.**

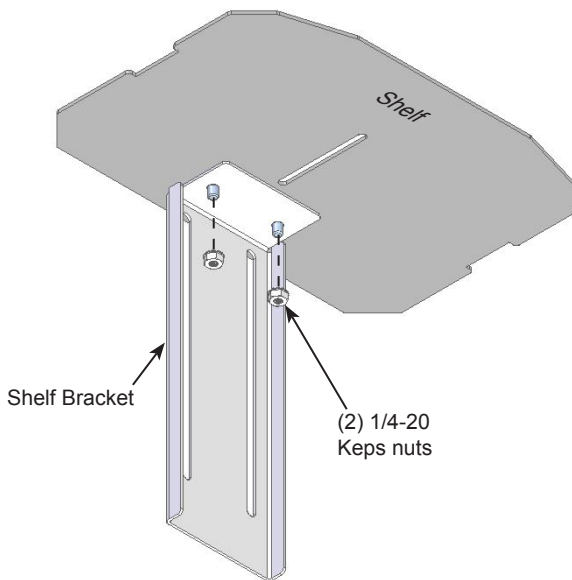
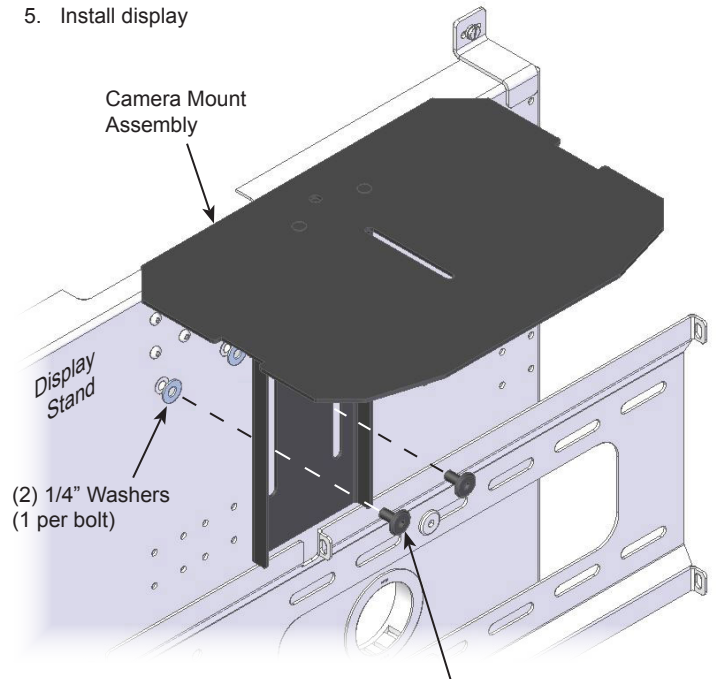

Figure 1

2. Install camera mount to display stand

1. Remove display from stand (if installed)
2. Attach the mount to the display stand with (2) 1/4-20 x 15mm JC bolts. Place (4) 1/4" washers behind the mount (2 per bolt). **Figure 2.**
3. Adjust the height so the mount will be above the installed display and tighten JC bolts
4. Install camera onto camera mount
5. Install display



(2) 1/4-20 x
15mm JC bolts

Figure 2