

## Technical Specifications

See p.4 for IMC components

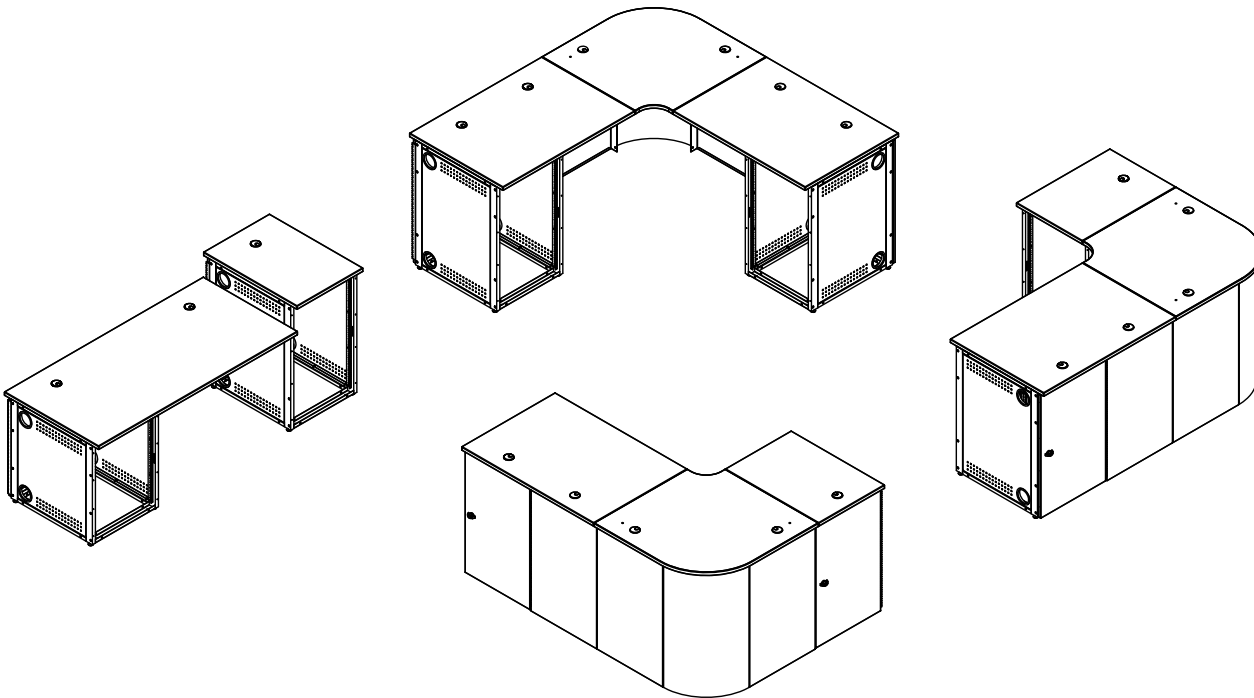

*The Instructor's Media Console is a modular system that consists of several base parts that can be assembled in a number of configurations to fit into your classroom, and meet your workspace and AV rack requirements. The IMC is available in two heights (29"H and 36"H) and consists of worksurfaces, corner panels, straight panels, equipment racks, and other parts to make a complete console.*

## Features and Benefits

- Modular design and wide variety of optional accessories allow easy configuration for any environment
- Scratch and impact-resistant high-pressure laminate top provides a durable, useful worksurface for instructors
- Worksurface provides ample room for papers, laptops, projectors, and most peripherals
- Equipment racks feature rack-rail equipment mounting
- Lockable access doors provide security and quick-access to the front and rear of the console making it easy to maintain audio, video, and multi-media equipment
- 2" round grommet(s) in worksurfaces (cover included)
- Side equipment rack grommet holes and worksurface grommets provide superior cord management
- Ventilated equipment rack side panels keep equipment cool
- Optional locking front doors can be mounted to swing from the left or right-hand side of the equipment rack
- Leveling glides keep unit level on uneven surfaces
- Durable powder coated steel chassis provides a long-lasting finish
- SCS Indoor Advantage Certified; meets or exceeds applicable ANSI-BIFMA test standards
- Warranted to be free of all defects in materials and workmanship for 10 years
- Designed and assembled in Chippewa Falls, WI, USA

## Construction

- The worksurface is constructed from 1" thick NAUF (No Added Urea Formaldehyde) composite board plus .030" high-pressure laminate on one face, and a balancing phenolic backer on the opposing face
- Worksurface edges are covered with black 3mm vinyl edgeband
- Equipment racks are made of welded, 1" x 1" and 1" x 2" rectangular 16-gauge steel tubing
- Equipment rack side panels are 20-gauge steel
- Filler panels and doors are 16-gauge steel
- Front and rear doors have full-length piano hinges
- All metal components are finished with a scratch-resistant powder coat epoxy
- IMC components are shipped knocked-down (KD) and require assembly

## Ordering Instructions

Spectrum has designed this console to receive the useful options shown here. To ensure your lectern and options are ordered correctly please call 1-800-235-1262.

## Color Options

Worksurface and metal available in some Spectrum Expressions colors. See [spectrumfurniture.com](http://spectrumfurniture.com) for complete color information.

Note: IMC edgebanding is only available in black at this time.

# Specifications

Worksurface sizes available	Single: 21.1875"W [53.8 cm] x 30"D [76.2 cm] Double: 42.375"W [107.6 cm] x 30"D [76.2 cm] Triple: 63.5625"W [161.4 cm] x 30"D [76.2 cm]	Radius corner worksurface: 36.047"W [91.6 cm] x 36.047"D [91.6 cm]
Equipment Rack Rails	<ul style="list-style-type: none"> <li>• 18RU - (36"H)</li> <li>• 14RU - (29"H)</li> </ul>	
Worksurface heights available	<ul style="list-style-type: none"> <li>• 36"H [91.4 cm]</li> <li>• 29"H [73.7 cm]</li> </ul>	
Unit weights	See console components on p.4	

Specifications subject to change without notice

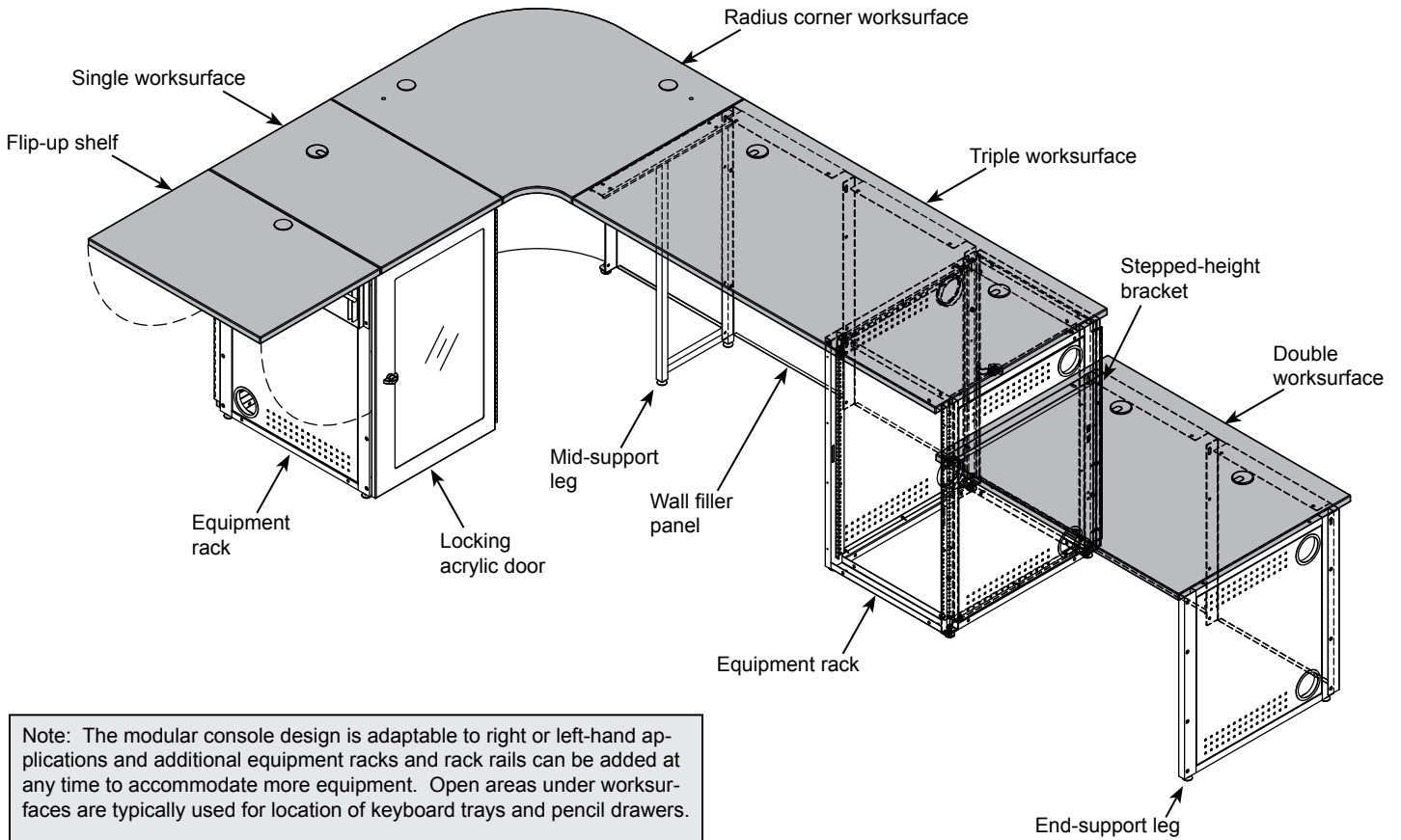

Note: The modular console design is adaptable to right or left-hand applications and additional equipment racks and rack rails can be added at any time to accommodate more equipment. Open areas under work-surfaces are typically used for location of keyboard trays and pencil drawers.  
2" worksurface grommet(s) include plastic covers.

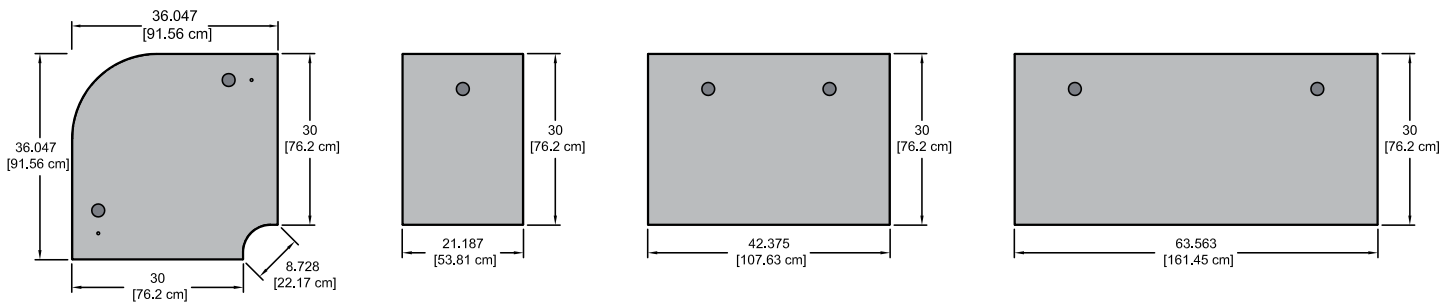

Radius corner worksurface .375"  
[.953 cm] hole drilled on each side  
for monitor arm mounting. 2" hole  
for cord routing

Single worksurface

Double worksurface

Triple worksurface

Note: Modified worksurface cutouts should be reviewed by Spectrum to ensure clearance of brackets, keyboard slides, or other objects under the worksurface.



## Worksurface Support Guidelines

For adequate support, areas under worksurfaces generally should not exceed a span of more than 2 open spaces (or wall filler panels) wide.

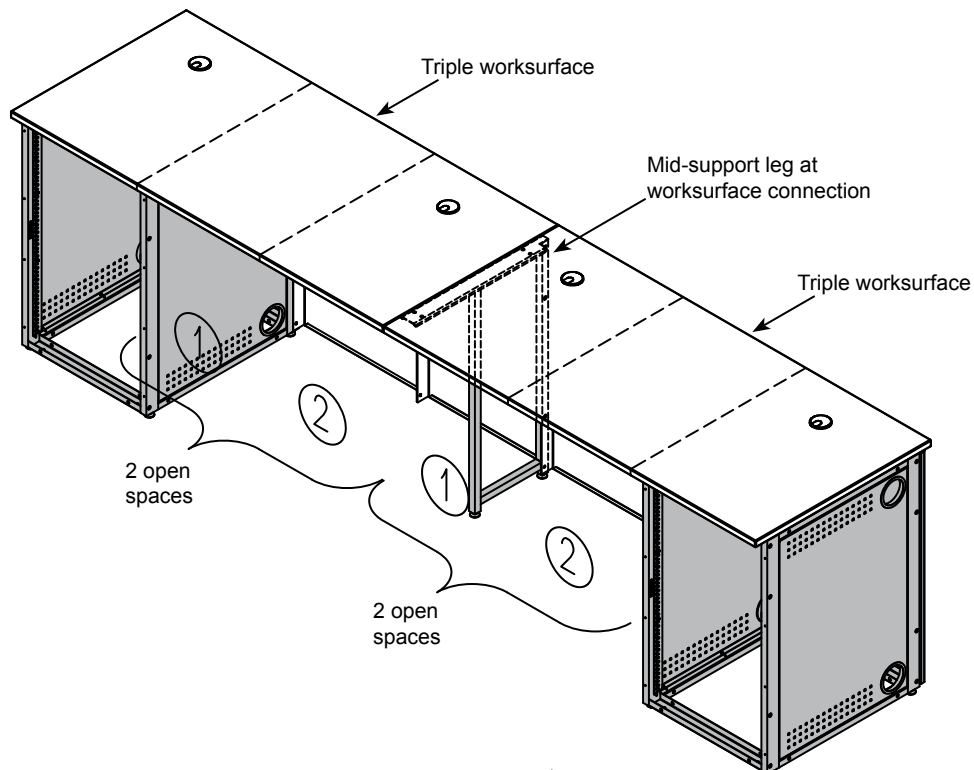
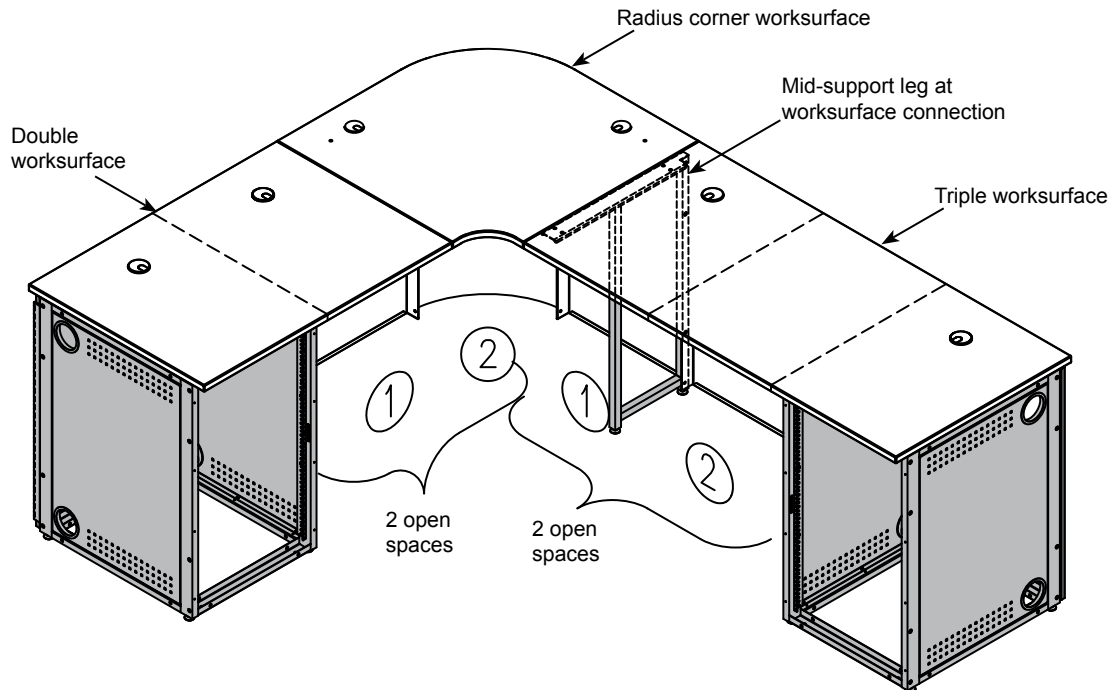
- When a radius corner is used with two double worksurfaces that have equipment rack support, a mid-support leg usually is not necessary
- When a radius corner is next to a double worksurface, an equipment rack or mid-support leg should be used to support the double worksurface
- When a triple worksurface is specified, at least one equipment rack should be used underneath to provide adequate support
- Mid-support legs are used at the seam two worksurfaces
- End-support legs are used at the end of a worksurface

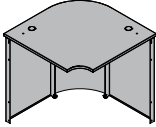
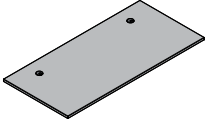
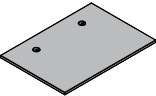
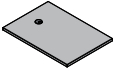
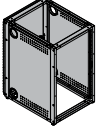

# Instructor Media Console Components

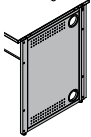
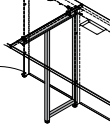
	Product Number	Description	Dimensions	Unit Weight
	68156	36H Radius Corner	36"W [91.44 cm] x 36"D [91.44 cm] x 36"H [91.44 cm]	135 lb [61.3 kg]
	68106	29"H Radius Corner	36"W [91.44 cm] x 36"D [91.44 cm] x 29"H [73.66 cm]	130 lb [59 kg]
	68202	Triple worksurface	63.5625"W [161.45 cm] x 30"D [76.2 cm] x 1"H [2.54 cm]	65 lb [29.5 kg]
	68201	Double Worksurface	42.375"W [107.6 cm] x 30"D [76.2 cm] x 1"H [2.54 cm]	46 lb [20.9 kg]
	68200	Single Worksurface	21.1875"W [53.8 cm] x 30"D [76.2 cm] x 1"H [2.54 cm]	28 lb [12.7 kg]
	68157	36" Equipment Rack	21.1875"W [53.8 cm] x 30"D [76.2 cm] x 36"H [91.44 cm]	64 lb [29.1 kg]
	68107	29" Equipment Rack	21.1875"W [53.8 cm] x 30"D [76.2 cm] x 29"H [73.7 cm]	50 lb [22.7 kg]
	68151	36" Wall Filler Panel	21.1875"W [53.8 cm] x 1"D [2.54 cm] x 36"H [91.44 cm]	18 lb [8.2 kg]
	68101	29" Wall Filler Panel	21.1875"W [53.8 cm] x 1"D [2.54 cm] x 29"H [73.7 cm]	15 lb [6.8 kg]
	68155	36" End-Support Leg	1"W [2.54 cm] x 30"D [76.2 cm] x 36"H [91.44 cm]	20 lb [9.1 kg]
	68105	29" End-Support Leg	1"W [2.54 cm] x 30"D [76.2 cm] x 29"H [73.66 cm]	16 lb [7.3 kg]
	68154	36" Mid-Support Leg	1"W [2.54 cm] x 24"D [61 cm] x 28"H [71.1 cm]	11 lb [5 kg]
	68104	29" Mid-Support Leg	1"W [2.54 cm] x 24"D [61 cm] x 21"H [53.3 cm]	9 lb [4.1 kg]

# Standard Console Configurations

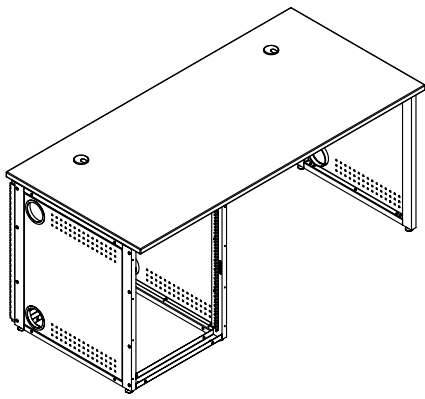

Console #1 (29"H) - 68020		
Qty	Description	Item
1	Triple Worksurface	68202
1	29" Equipment Rack	68107
2	29" Wall Filler Panel	68101
1	29" End-Support Leg	68105

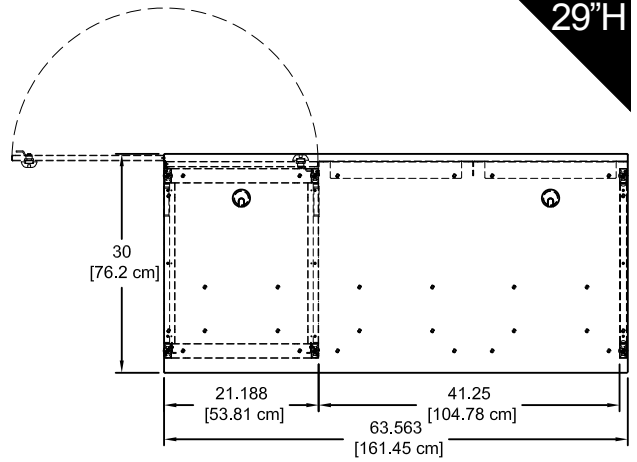
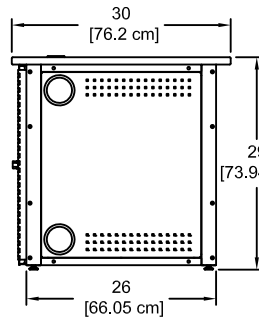

29"H

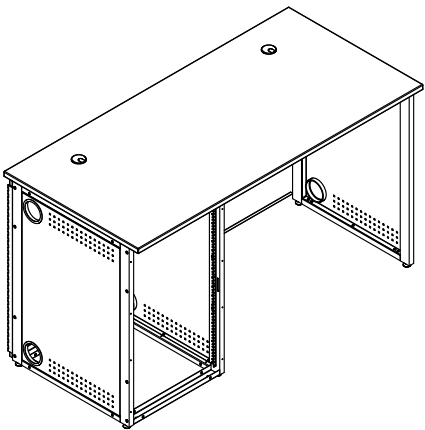

Console #1 (36"H) - 68021		
Qty	Description	Item
1	Triple Worksurface	68202
1	36" Equipment Rack	68157
2	36" Wall Filler Panel	68151
1	36" End-Support Leg	68155

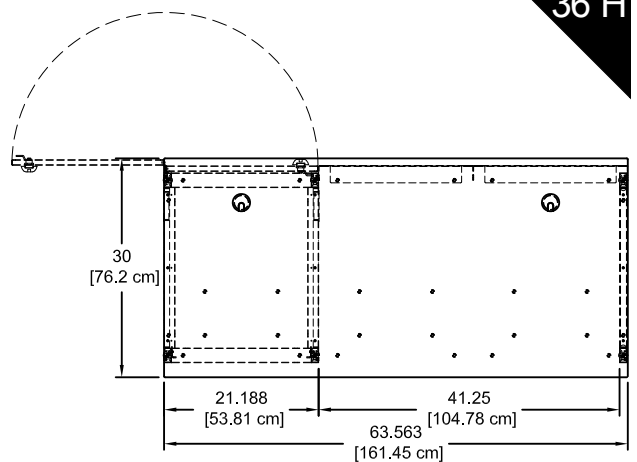
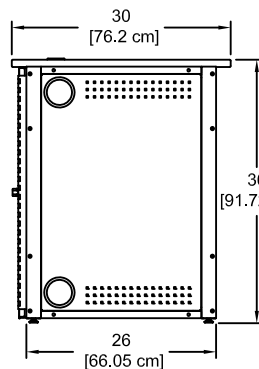

36"H

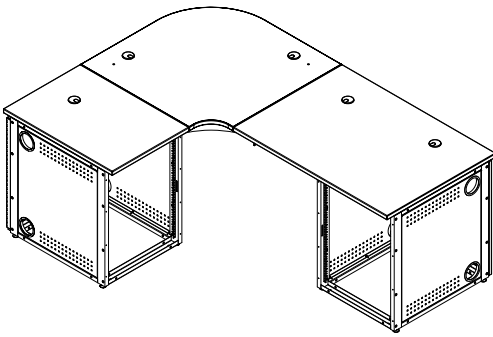

29"H

Console #2 (29"H) - 68022		
Qty	Description	Item
1	29" Radius Corner	68106
1	Double Worksurface	68201
1	Single Worksurface	68200
2	29" Equipment Rack	68107
1	29" Wall Filler Panel	68101

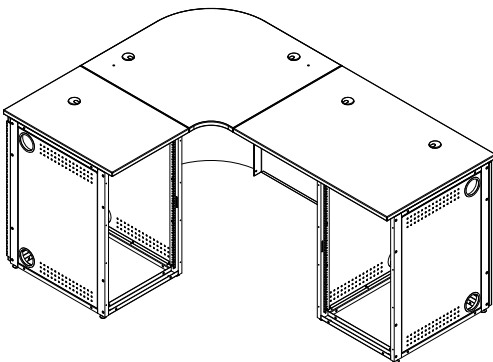
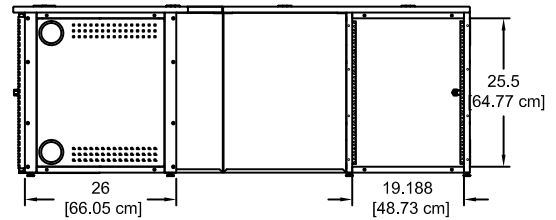
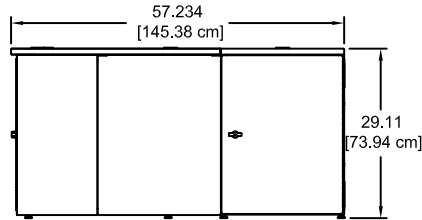
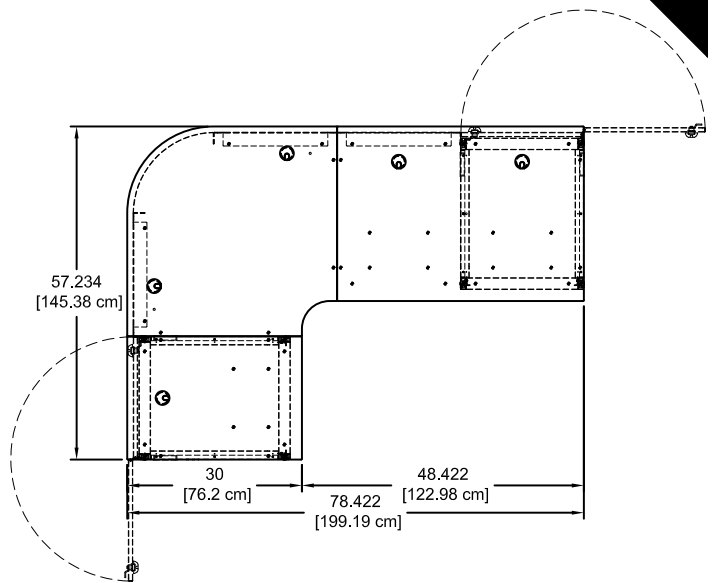

36"H

Console #2 (36"H) - 68023		
Qty	Description	Item
1	36" Radius Corner	68156
1	Double Worksurface	68201
1	Single Worksurface	68200
2	36" Equipment Rack	68157
1	36" Wall Filler Panel	68151

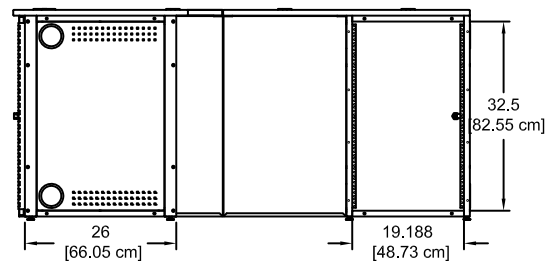
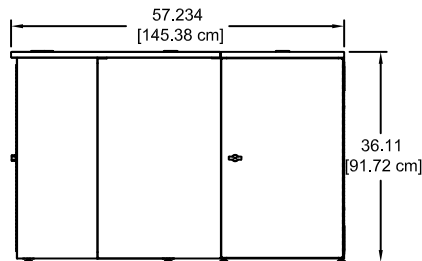
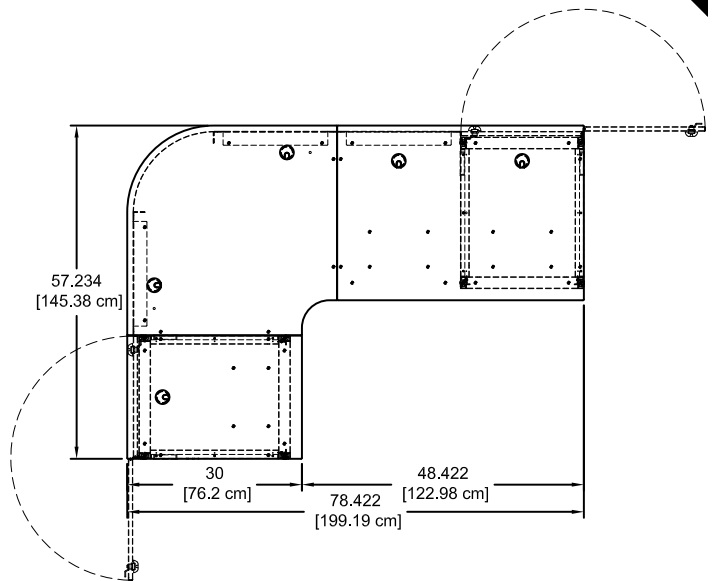

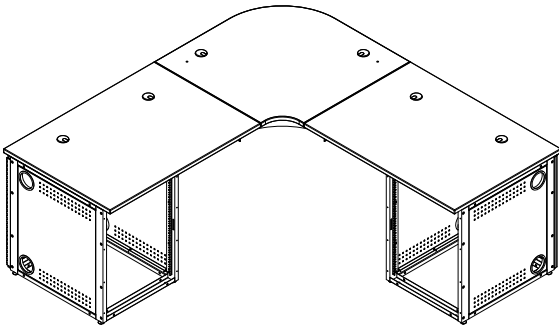

29"H

**Console #3 (29"H) - 68024**

Qty	Description	Item
1	29" Radius Corner	68106
2	Double Worksurface	68201
2	29" Equipment Rack	68107
2	29" Wall Filler Panel	68101

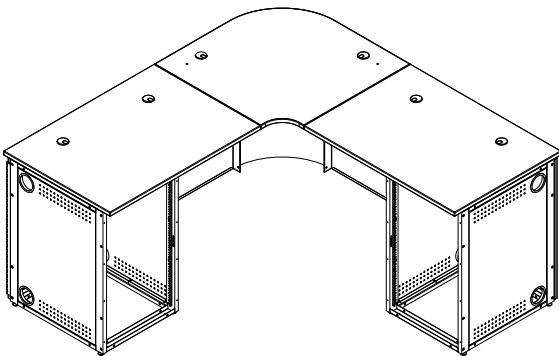
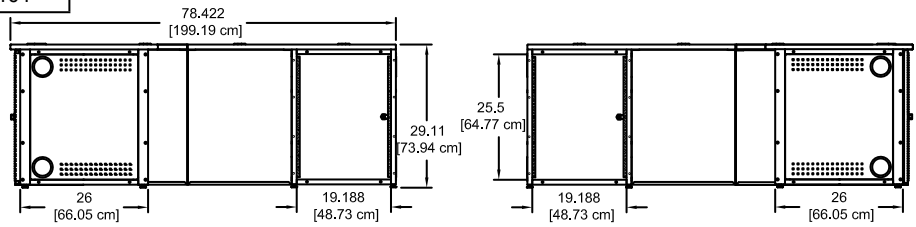
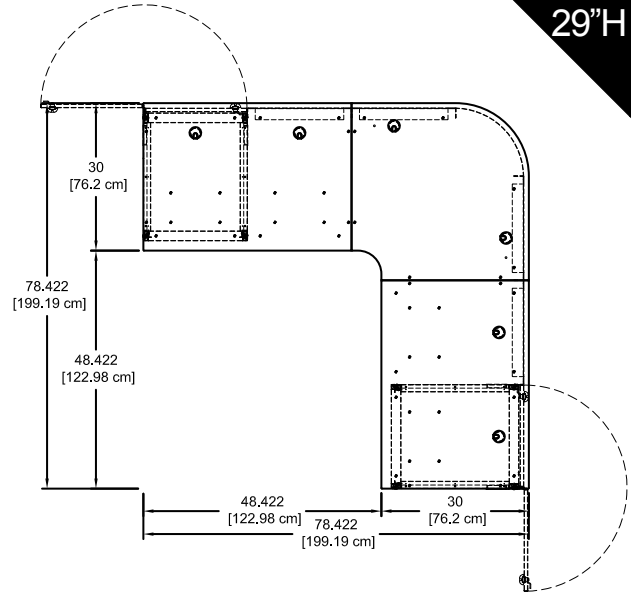

36"H

**Console #3 (36"H) - 68025**

Qty	Description	Item
1	36" Radius Corner	68156
2	Double Worksurface	68201
2	36" Equipment Rack	68517
2	36" Wall Filler Panel	68151

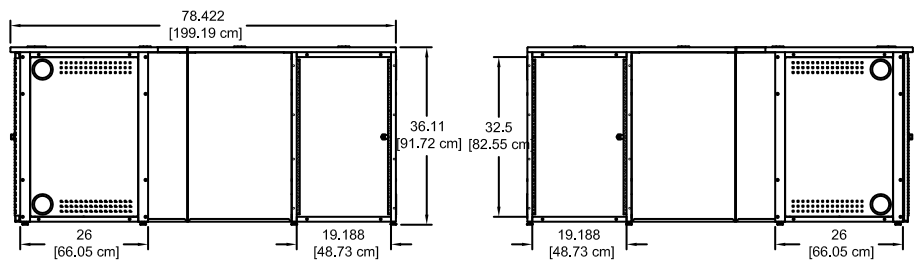
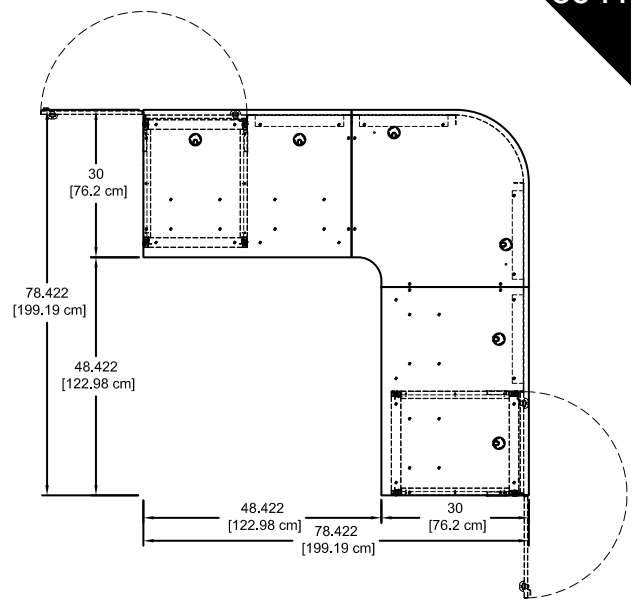

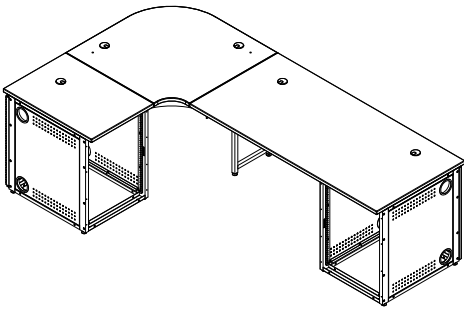

29"H

Console #4 (29"H) - 68026		
Qty	Description	Item
1	29" Radius Corner	68106
1	Triple Worksurface	68202
1	Single Worksurface	68200
2	29" Equipment Rack	68107
2	29" Wall Filler Panel	68101
1	29" Mid-Support Leg	68104

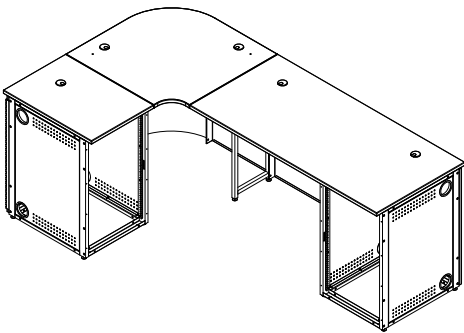
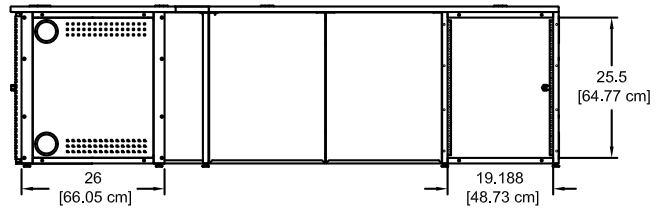
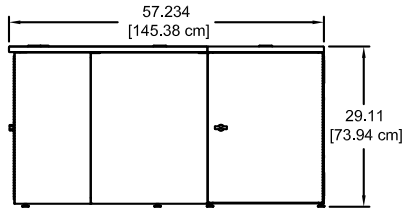
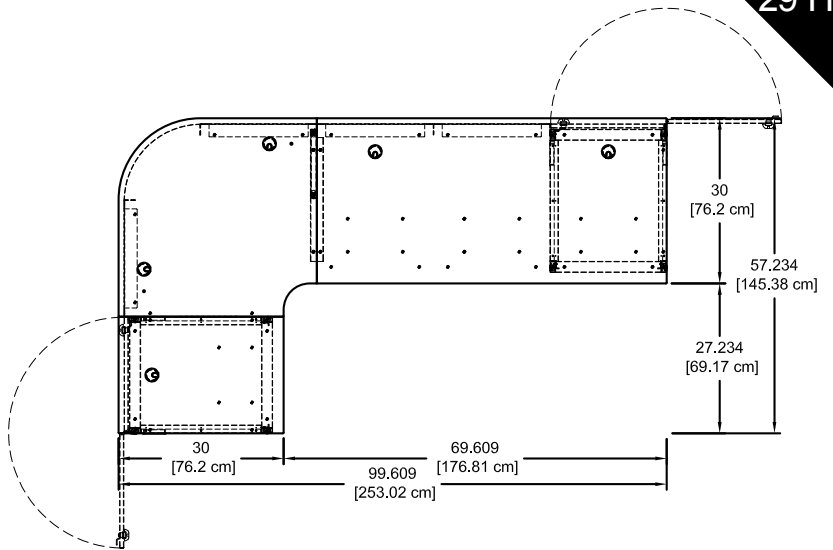

36"H

Console #4 (36"H) - 68027		
Qty	Description	Item
1	36" Radius Corner	68156
1	Triple Worksurface	68202
1	Single Worksurface	68200
2	36" Equipment Rack	68157
2	36" Wall Filler Panel	68151
1	36" Mid-Support Leg	68154

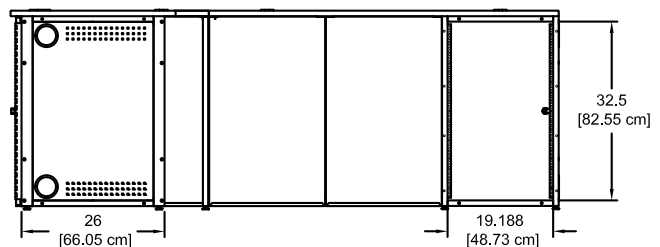
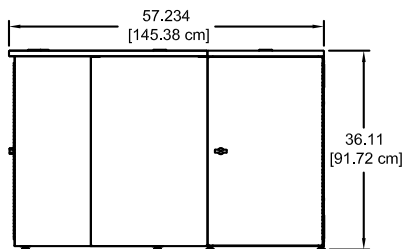
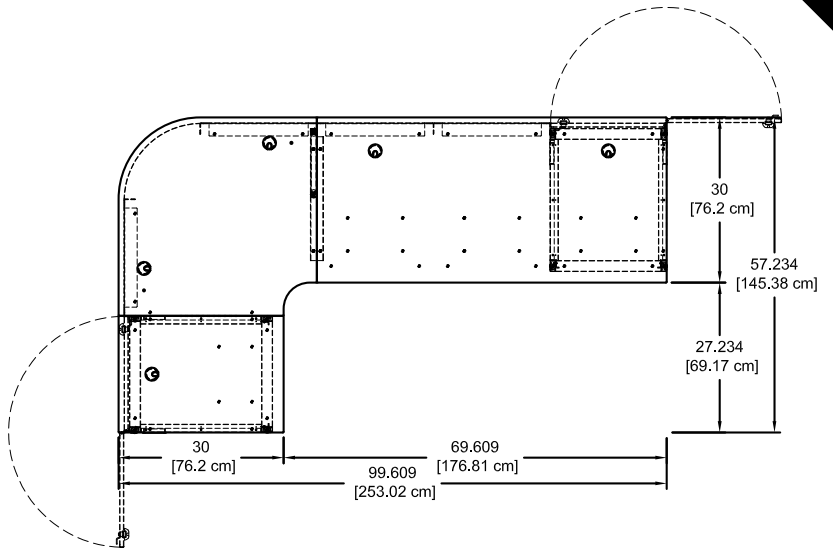



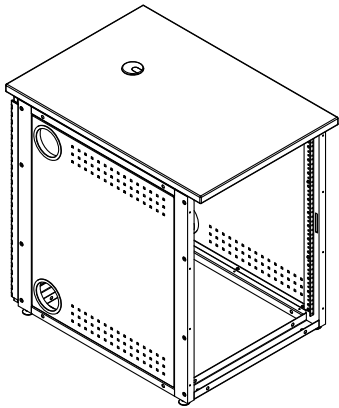

**29" H**

**Console #5 (29"H) - 68028**

Qty	Description	Item
1	Single Worksurface	68200
1	29" Equipment Rack	68107

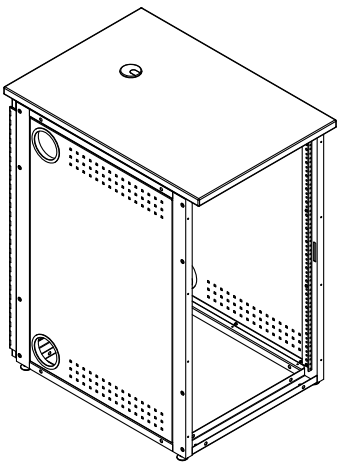
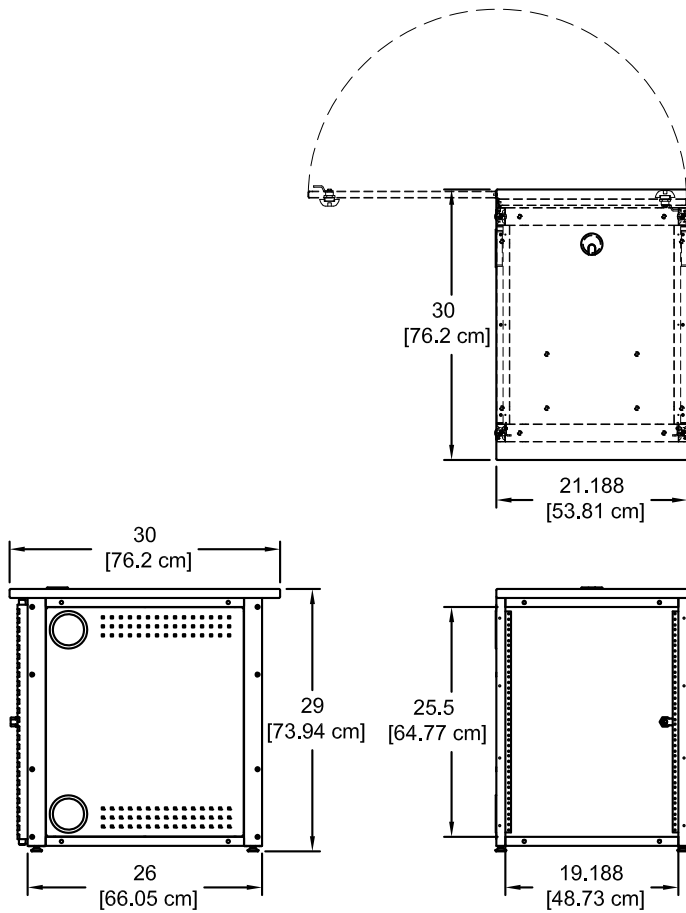

**36" H**

**Console #5 (36"H) - 68029**

Qty	Description	Item
1	Single Worksurface	68200
1	36" Equipment Rack	68157

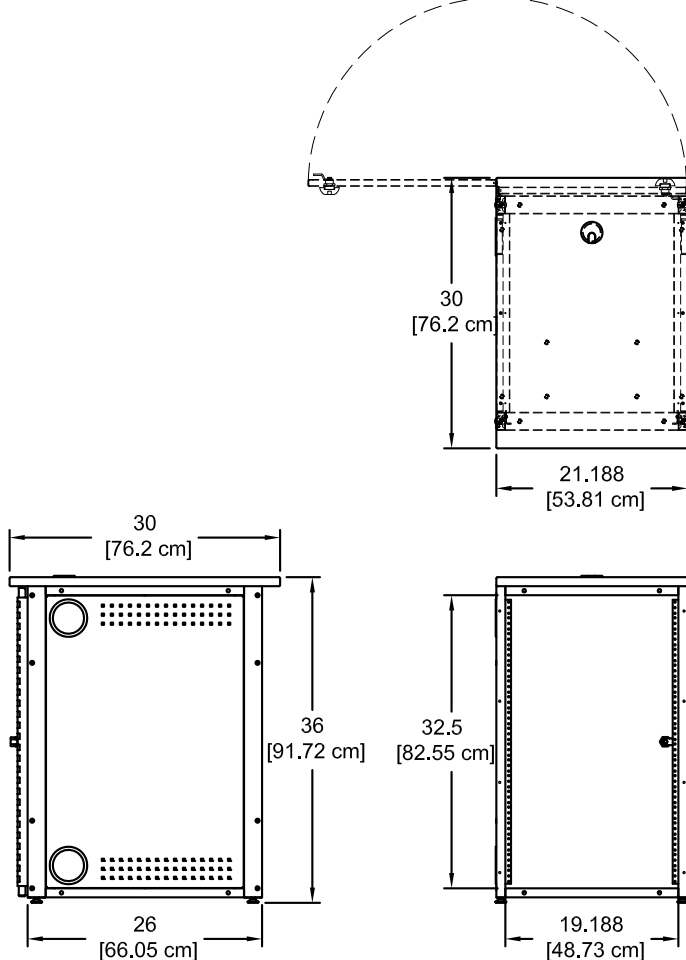

Console #6 - 68030		
Qty	Description	Item
1	Triple Worksurface	68202
1	Single Worksurface	68200
1	29" Equipment Rack	68107
2	29" Wall Filler Panel	68101
1	36" Equipment Rack	68157
1	Stepped-Height Bracket	68205

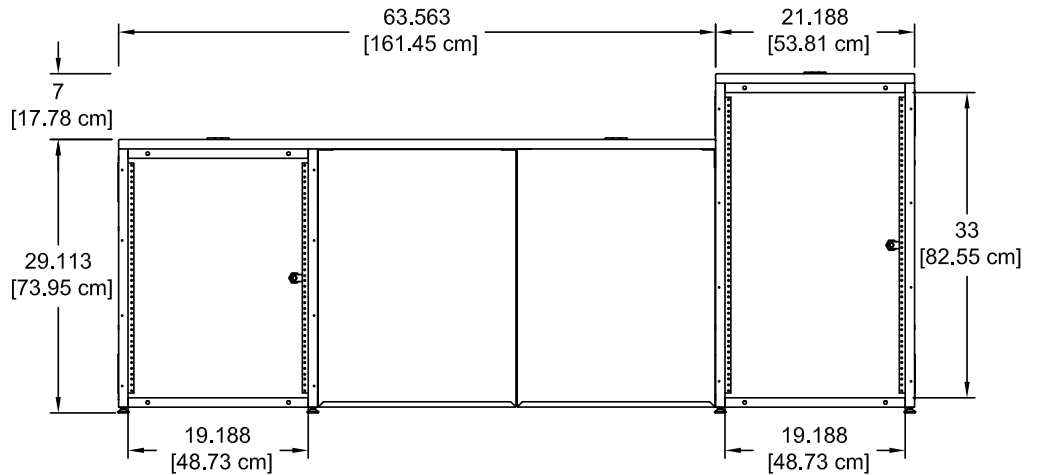
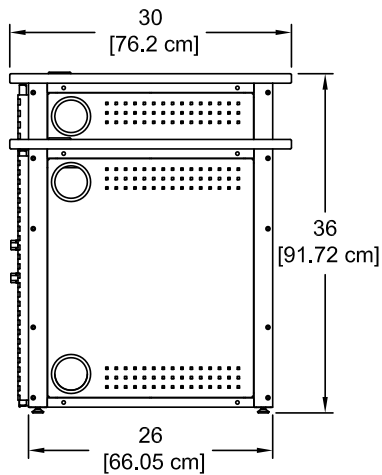
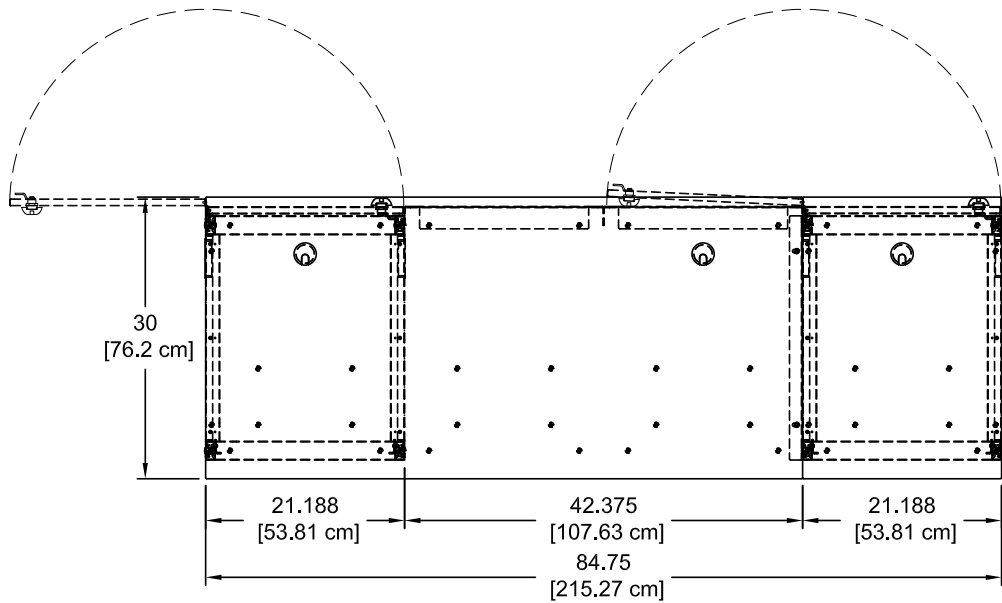
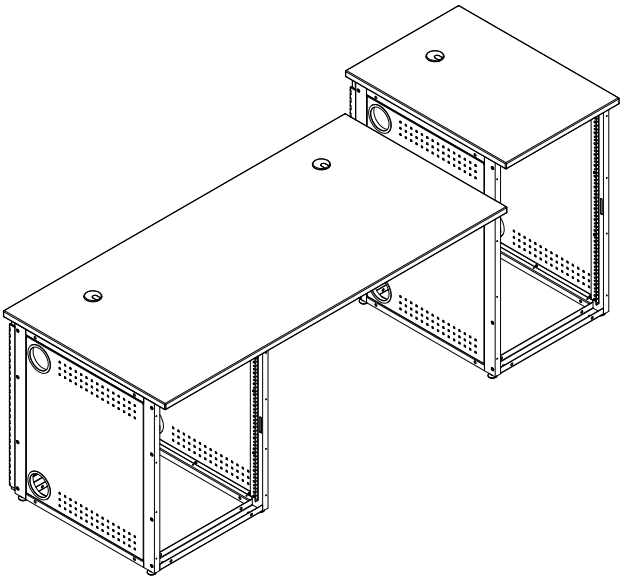

29" Equipment rack  
section view

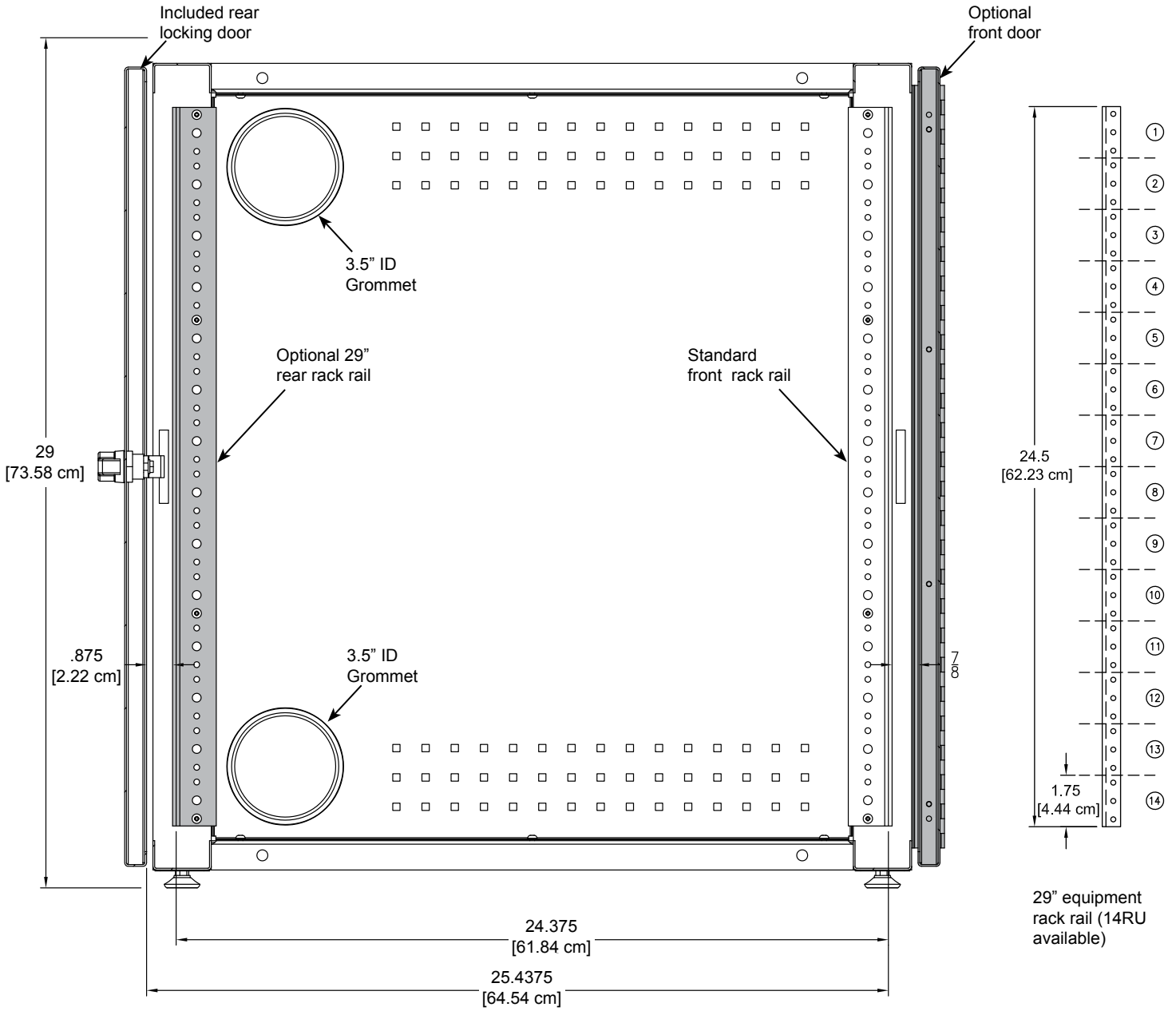

29" equipment rack rail (14RU available)

36" Equipment rack  
section view

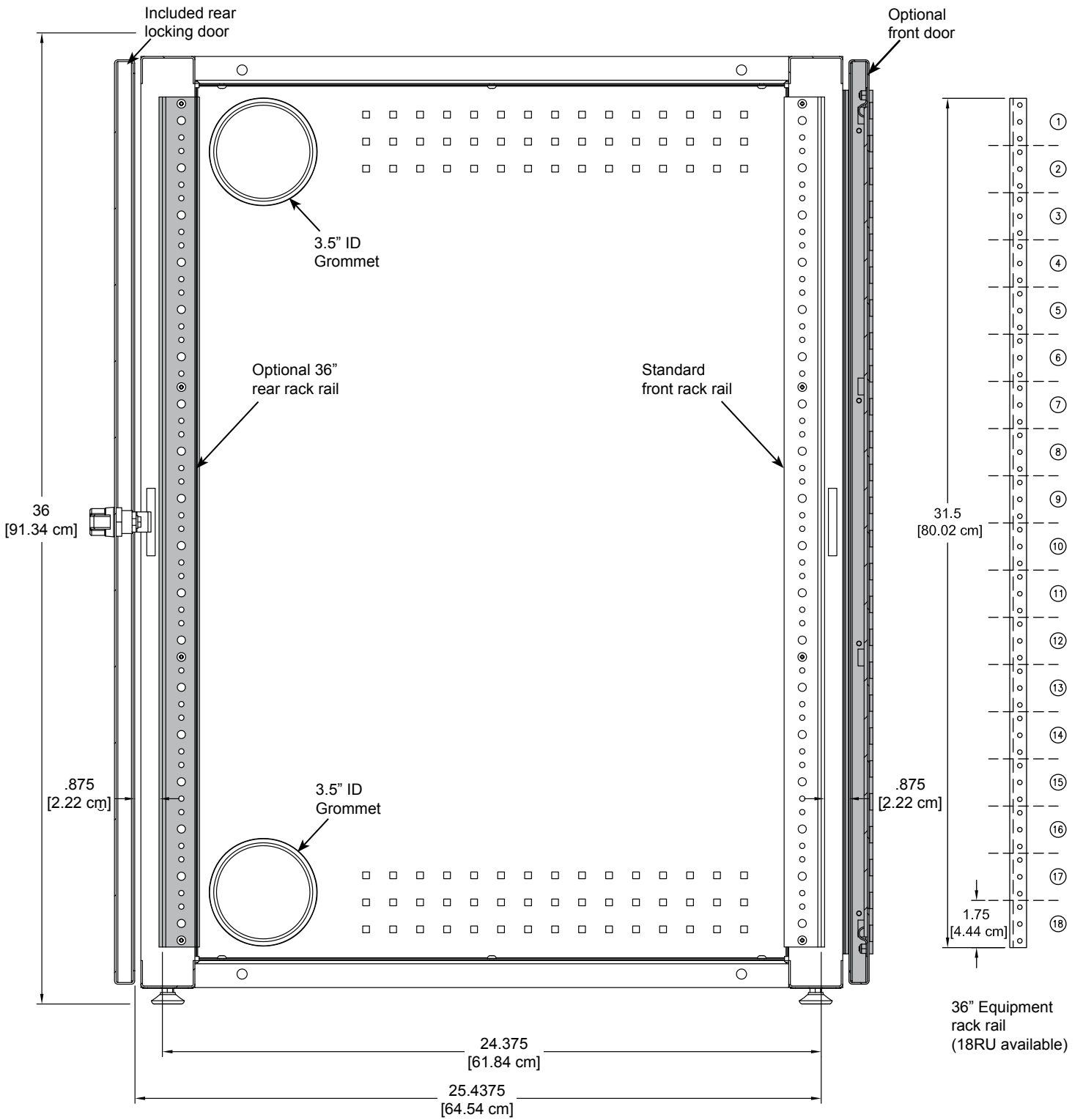

# Accessories

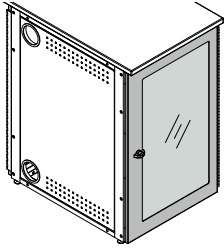

**Clear Acrylic Locking Door**  
 36"H - 68153  
 29"H - 68103

- For instructor-side installation
- Can be installed to be hinged from the left or right side

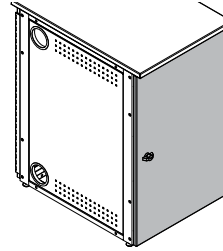

**Solid Locking Door**  
 36"H - 68152  
 29"H - 68102

- For instructor-side installation
- Can be installed to be hinged from the left or right side

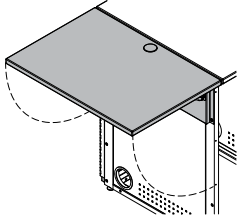

**Flip-up Shelf - 68204**

- Shelf hinges lock into place in the upright position
- Shelf mounts level with worksurface
- Includes 2" grommet
- Mounting plate available in black or dark gray

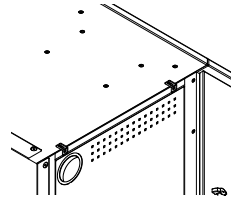

**Level-Height Bracket Kit - 68207**

- Attaches a worksurface to another worksurface of equal height over an equipment rack

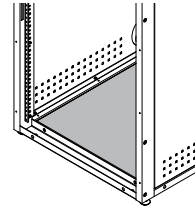

**Equipment Rack Bottom Shelf - 68203**

- Increases security
- Prevents static electricity and dust build-up
- Includes 4" grommet at back

Not for use on end-support legs or stand-alone equipment racks

Weight capacity: 35 lb [15.9 kg]  
 Dimensions: 21.1875"W [53.8 cm] x 30"D [76.2 cm] x 1"H [2.54 cm]  
 Unit weight: N/A  
 Shipping weight: 27.5 lb [12.5 lb]

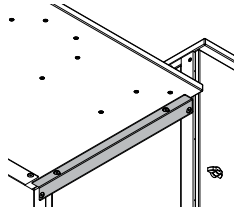

**Stepped-Height Bracket - 68205**

- Connects 29"H console to 36"H console



**Rear Rack Rail Kit**  
 36"H - 68150  
 29"H - 68100

- Adds 18RU or 14RU to rear of equipment rack
- Set of 2

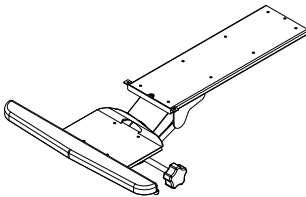

**Econo Keyboard Tray - 95520**

- 18.375"W [46.7 cm] x 12"D [30.5 cm]

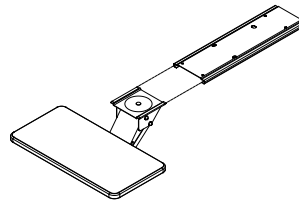

**Micro-Arm Keyboard Tray - 95506**

- Slides in, out, up and down
- 19.75"W x 10"D

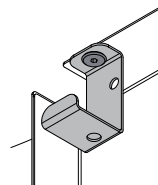

**Wire Management Clips - 68206**

- Mounts under worksurface
- Set of 3

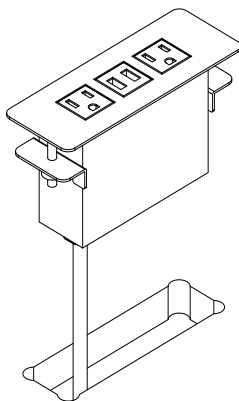

**Power Module - 99058**

- (2) AC power receptacles
- (2) USB charge ports
- Aluminum housing and flange
- Thumbscrew clamps
- Requires worksurface cutout
- ETL-certified
- Available in black, silver, or white
- Customer-installed

Cutout required: 5.65"W [14.35 cm] x 1.65"D [4.19 cm]  
 Power cord: 10' [305 cm] 14AWG \*3C power cord  
 Power receptacles: 125V, 60hz, 15A tamper-resistant  
 USB charging ports: 2.1A (10.5W) (not data-compatible)  
 Dimensions: 6.38"W [16.2 cm] x 2.36"D [6 cm] x 3.54"H [9 cm]  
 Unit weight: 2 lb [.9 kg]  
 Shipping weight: 2.35 lb [1 kg]





#### **Flat Panel Monitor Arm**

**95512** - "Light-Duty" for monitors weighing 2-13 lb [.9-5.9 kg]

**95522** - "Medium-Duty" for monitors weighing 7.5-25 lb [2.5-11.4 kg]

**95509** - "Heavy-Duty" for monitors weighing 12-31 lb [5.4-14 kg]

- Six mounting options (clamp, thru-desk, wall, grommet hole, side bolt, reverse wall)
- Compatible with all VESA® monitors – includes 75mm and 100mm VESA® adapters
- Cable management concealed in arm



#### **Dual Flat Panel Monitor Arm - 95533**

- Weight range: 3.5-13 lb [1.6-5.9 kg] per monitor
- Six mounting options (clamp, thru-desk, wall, grommet hole, side bolt, reverse wall)
- Compatible with all VESA® monitors – includes 75mm and 100mm VESA® adapters
- Cable management concealed in arm

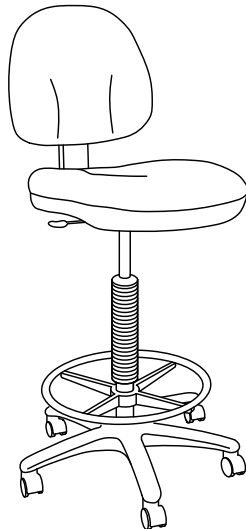

#### **Adjustable Drafting Stool - 38202**

- 40-52" height-adjustment via pneumatic cylinder
- 360° swivel
- Tilting backrest
- 18" diameter fixed foot ring
- 5-star base

# Rack-mount Accessories

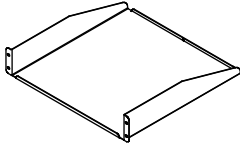

## Cantilever Shelf - 2RU - 97504

- 16ga steel
- Shelf: 17.5"W [44.45 cm] x 18"D [45.7 cm] x 3.5"H [8.89 cm]
- Weight capacity: 50 lb [22.7 kg]
- Shipping weight: 8.1 lb [3.7 kg]

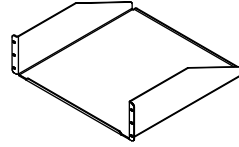

## Cantilever Shelf - 3RU - 97502

- 16ga steel
- Shelf: 17.5"W [44.45 cm] x 18"D [45.7 cm] x 5.25"H [13.33 cm]
- Weight capacity: 80 lb [36.3 kg]
- Shipping weight: 9.2 lb [4.2 kg]

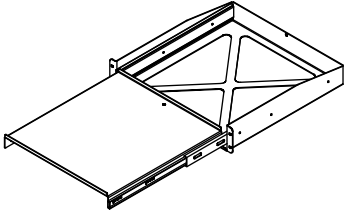

## Pull-Out Shelf - 2RU - 97505

- 16ga steel
- 17.09"W [43.42 cm] x 18.12"D [46.03 cm] x 3.5"H [8.89 cm]
- Weight capacity: 50 lb [22.7 kg]
- Shipping weight: 15.6 lb [7.1 kg]

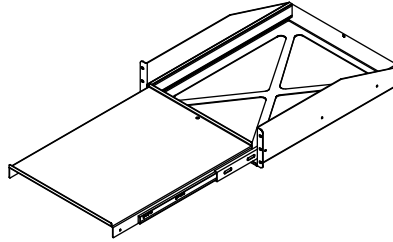

## Pull-Out Shelf - 3RU - 97503

- 16ga steel
- 17.09"W [43.42 cm] x 22.11"D [56.14 cm] x 5.25"H [13.33 cm]
- Weight capacity: 80 lb [36.3 kg]
- Shipping weight: 18.5 lb [8.4 kg]

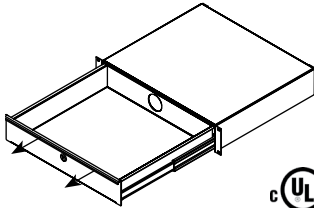

## Locking Drawer - 2RU - 97523

- 16ga steel
- Drawer: 15.97"W [40.56 cm] x 14.56"D [36.98 cm] x 3"H [7.63 cm]
- Weight capacity: 50 lb [22.7 kg]
- Shipping weight: 15.85 lb [7.2 kg]

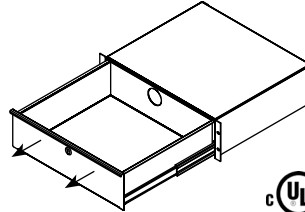

## Locking Drawer - 3RU - 97522

- 16ga steel
- Drawer: 15.97"W [40.56 cm] x 14.56"D [36.98 cm] x 5.25"H [13.33 cm]
- Weight capacity: 50 lb [22.7 kg]
- Shipping weight: 18.5 lb [8.4 kg]

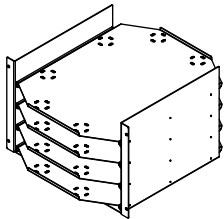

## LT-4 Laptop Storage Unit - 7RU - 97517

- Holds four full-size laptops
- 16ga & 20ga steel
- 18.75"W [47.94 cm] x 20.5"D [52.11 cm] x 12.25"H [31.11 cm]
- Shipping weight: 30 lb [13.6 kg]

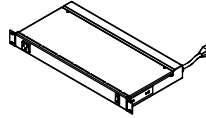

## 9-Outlet Power Strip - 1RU - 99021

- 8 outlets rear (breaker-protected)
- 1 convenience outlet front
- 115VAC, 60 Hz, 15 amps max
- 9' power cord
- Front LED power switch
- Enhanced surge protection
- ETL-listed, UL-listed
- 19"W [48.27 cm] x 9.25"D [23.5 cm] x 1.74"H [4.41 cm]
- Shipping weight: 8.7 lb [3.9 kg]

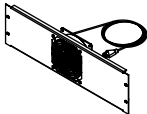

## Single Fan - 3RU - 97507

- 50 cfm
- 120V~50/60 Hz, 15/13W
- RoHS
- 19"W [48.27 cm] x 1.56"D [3.97 cm] x 5.25"H [13.33 cm]
- Shipping weight: 3.78 lb [1.7 kg]

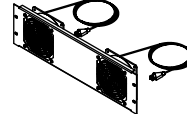

## Double Fan - 3RU - 97506

- 100 cfm
- 120V~50/60 Hz, 15/13W
- RoHS
- 19"W [48.27 cm] x 1.56"D [3.97 cm] x 5.25"H [13.33 cm]
- Shipping weight: 5.47 lb [2.5 kg]

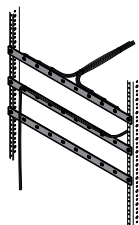

## Wire Lace Kit - 95517

- Provides wire management
- Mounts to standard rack rails
- Includes (3) lace straps and mounting screws
- Includes (12) 5.5" zip ties
- Shipping weight: 1.25 lb [.57 kg]

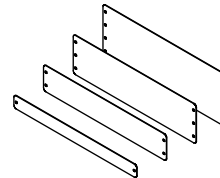

## Rack-Mount Blanks

**1RU - 97510**      **3RU - 97512**  
**2RU - 97511**      **4RU - 97513**

- Fills rack spaces where components are not needed
- 16 ga steel
- Shipping weight: <1 lb [.45 kg]

See [spectrumfurniture.com](http://spectrumfurniture.com) for the latest accessories and detailed warranty information.

## Warranty

### We will make it right for you!

Thanks for choosing Spectrum! Spectrum is committed to provide complete customer satisfaction. Each of our products is manufactured from the best materials available and each product is stringently monitored throughout the production process through our P.A.C.E. program (Product Assurance to meet Customer Expectations).

We expressly warrant that Spectrum products will be of good quality and workmanship and free from defect for the period set out in the warranty from the date of delivery.

**For a listing of all product specific warranty terms please visit our website at:**

<https://www.spectrumfurniture.com/en/resources/purchasing-terms-warranty>

**1-800-235-1262**

Toll-free HELPLINE

**[spectrum@spectrumfurniture.com](mailto:spectrum@spectrumfurniture.com)**



Spectrum Industries is Certified ISO 9001:2015