

Assembly Instructions

⚠ Important ⚠

Before you begin, read and comply with all safety and operating instructions, and ensure all parts and correct quantities are included.

Any parts damaged during shipment must be reported within 5 days of receipt. To report information regarding missing parts or damage, to purchase parts or accessories, or if you have any questions, please contact us.

www.spectrumfurniture.com
800-235-1262, 715-723-6750

Thank you for purchasing Spectrum products!

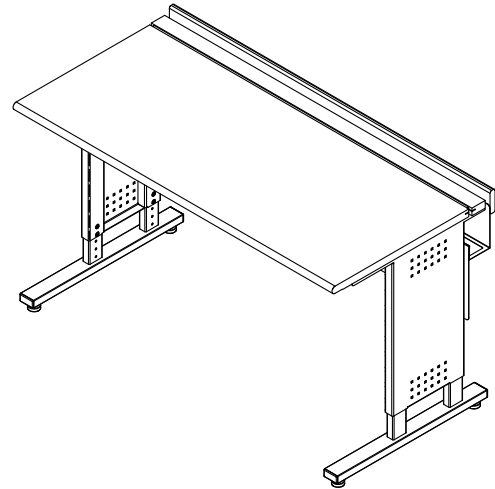

Evolution Desk 24\"/>

38912ADJ - 36\"/>

38915ADJ - 60\"/>

38916ADJ - 72\"/>

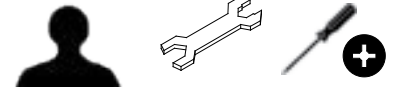
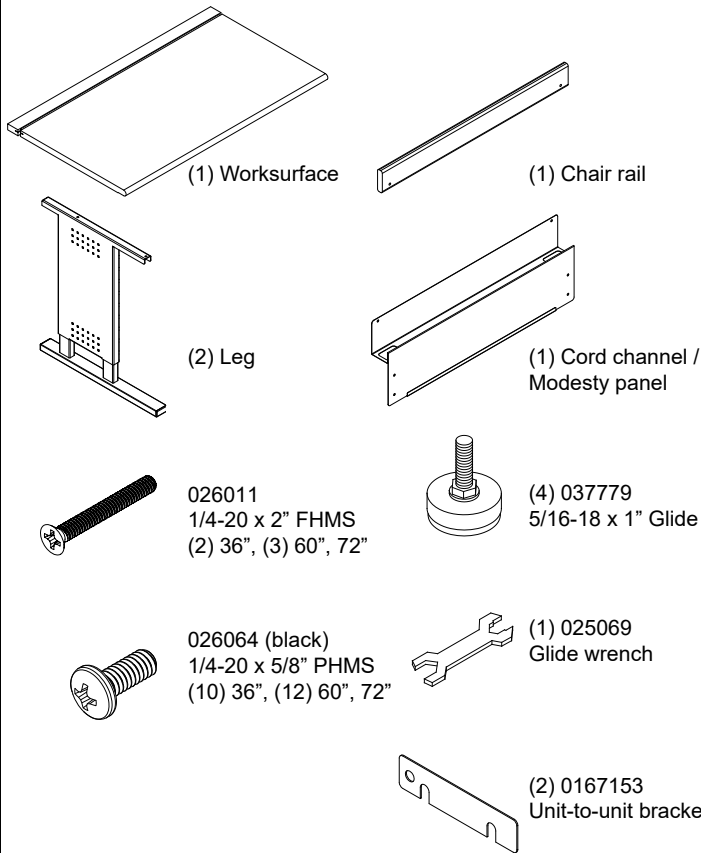

X2



Assembly tip: Do not tighten component fasteners completely until all have been installed. Keeping them loose will help with alignment between parts during assembly.

1 Attach chair rail bracket (60\"/>

- Place the worksurface face-down onto a non-abrasive surface.
- Orient and attach the chair rail bracket to the center of the worksurface as shown in **Figure 1** with (2) 1/4-20 x 5/8\"/>

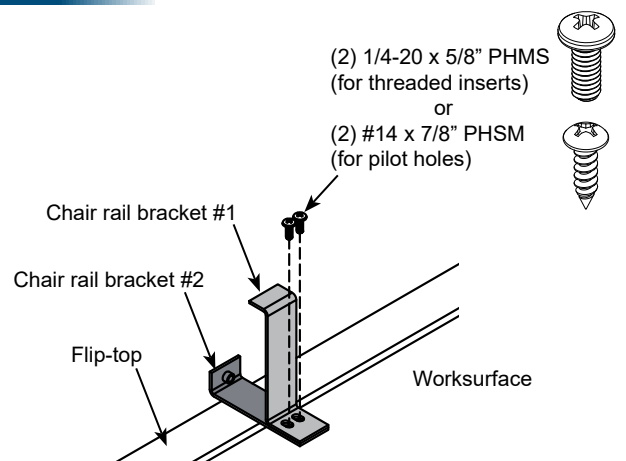
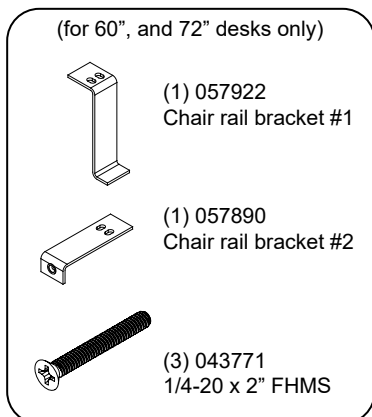
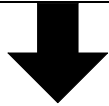
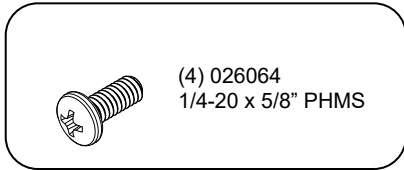

Figure 1

2 Attach legs to worksurface



Note: There are two types of Evolution legs—the newer style one-piece upper leg, and the original welded tube upper leg. Fasteners are provided for both types (included in leg box). Be sure to use the screws shown below with the corresponding leg.



One-piece upper leg



1. Place the worksurface face-down onto a non-abrasive surface.
2. Align the legs with the mounting holes, and install (2) 1/4-20 x 5/8" PHM screws into each leg but do not tighten completely yet.

Figure 2.1.

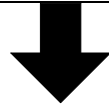
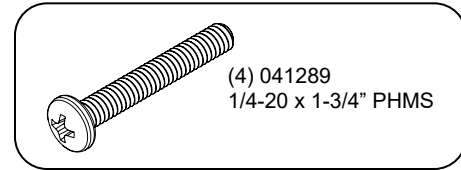

Welded tube upper leg

1. Place the worksurface face-down onto a non-abrasive surface.
2. Align the legs with the mounting holes, and install (2) 1/4-20 x 1-3/4" PHM screws into each leg but do not tighten completely yet.

Figure 2.2.

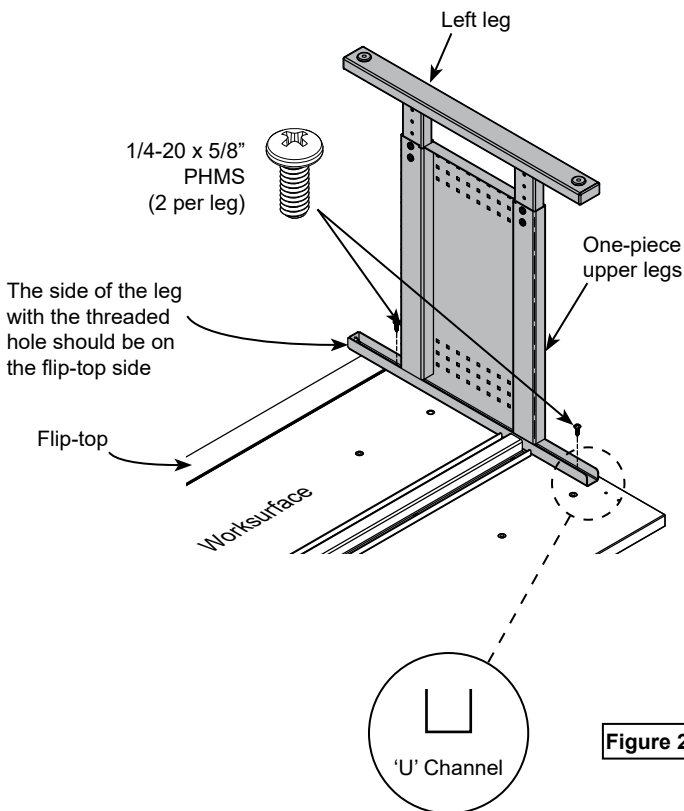

Figure 2.1

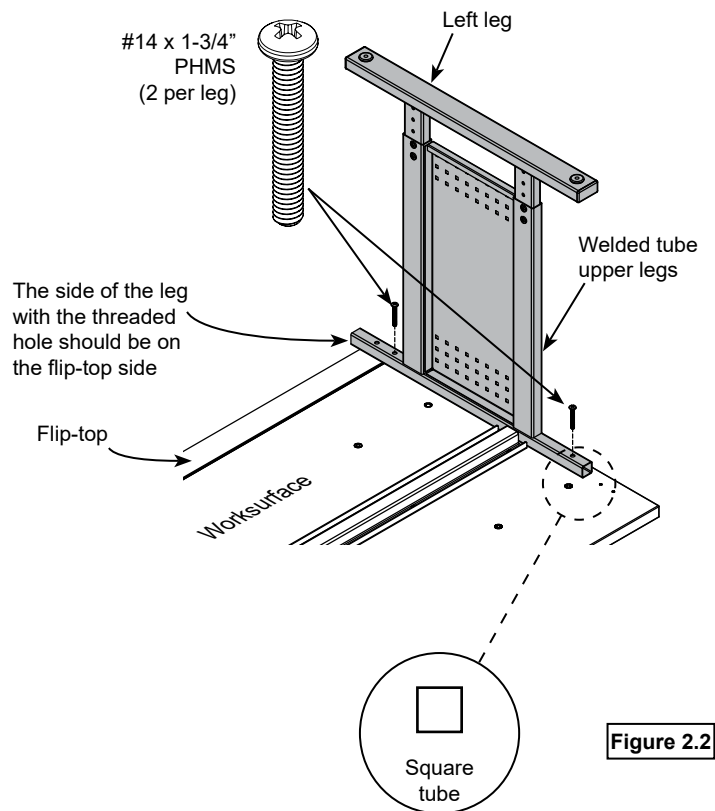

Figure 2.2

3 Install cord channel / modesty panel and glides

1. Orient the modesty panel/cord channel as shown and attach to the legs with (4) 1/4-20 x 5/8" PHM screws. **Figure 3.1.**

*Note: If you are assembling a 60, or 72" desk, slide the cord channel over the chair rail bracket. The bracket will support the inside of the cord channel. **Figure 3.2.***

2. Install the (4) glides to the bottom of the legs. The glides can be adjusted later to keep the desk level on uneven surfaces.
3. Tighten ALL screws.

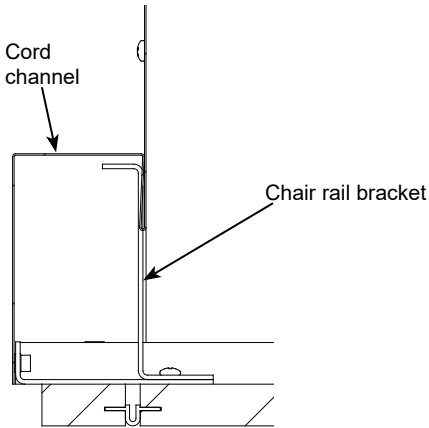

Figure 3.2

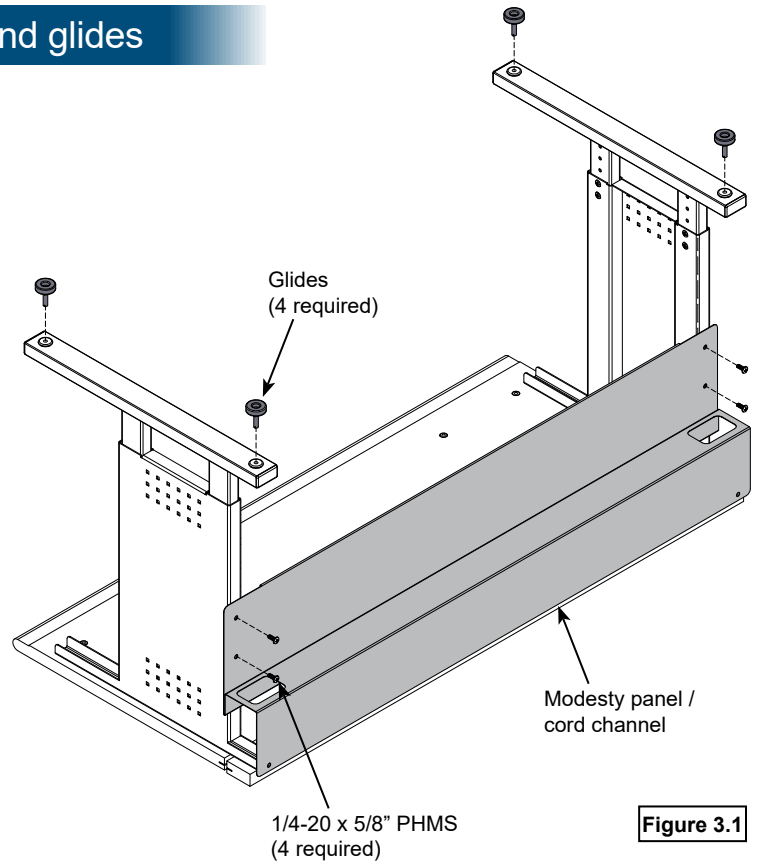

Figure 3.1

Leg adjustment

The worksurface height can be adjusted from 24"H - 32"H in 1" increments.
Figure 3.3. Adjustment is easier when the desk is upside-down.

1. To adjust the legs, remove the (4) pre-installed adjustment screws. (Fully-support the lower section of the leg while removing). **Figure 3.4.**
2. Choose a height and align the corresponding set of leg holes.
3. Install the (4) previously removed screws in the new holes and tighten securely.
4. Repeat this procedure on the second leg. Make sure to use the same set of holes as used on the first leg.

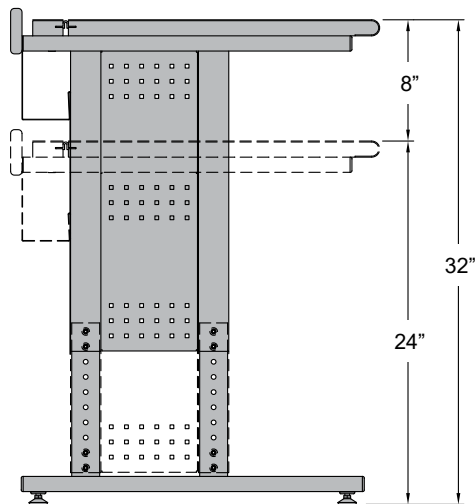

Figure 3.3

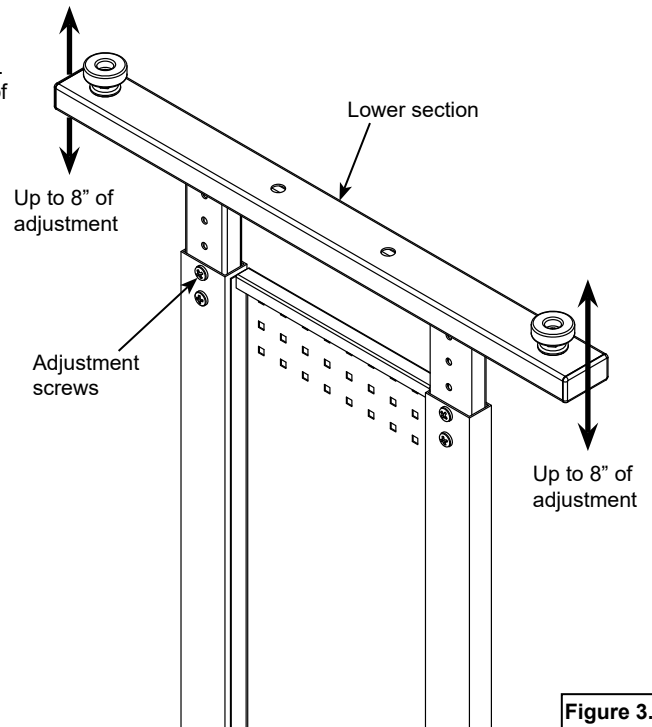

Figure 3.4

4 Attach chair rail

1. Carefully stand the desk upright-this will require at least two people.
2. Attach the chair rail with (2) 1/4-20 x 2" FHM screws as shown. **Figure 4.1, 4.2.** The chair rail should extend above the worksurface, and the countersunk holes should be on the outside.

Note: If you are assembling a 60 or 72" desk, attach the center of the chair rail to the chair rail bracket using the 3rd flat head screw. (The chair rail bracket may require slight adjustment to align properly.)

3. For 60" & 72" desks only: Using the 3rd flat head screw, attach the center of the chair rail to the chair rail bracket. (The chair rail bracket may require slight adjustment for proper alignment).
4. Tighten all screws securely.

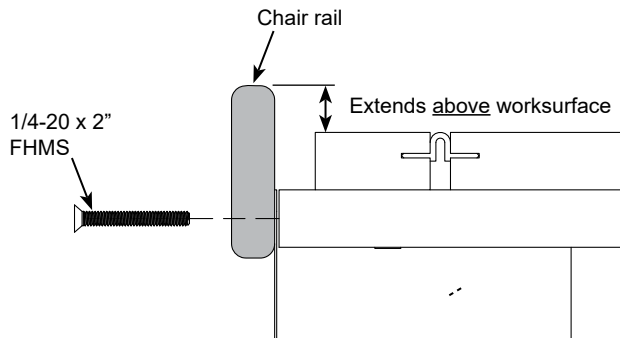

Figure 4.1

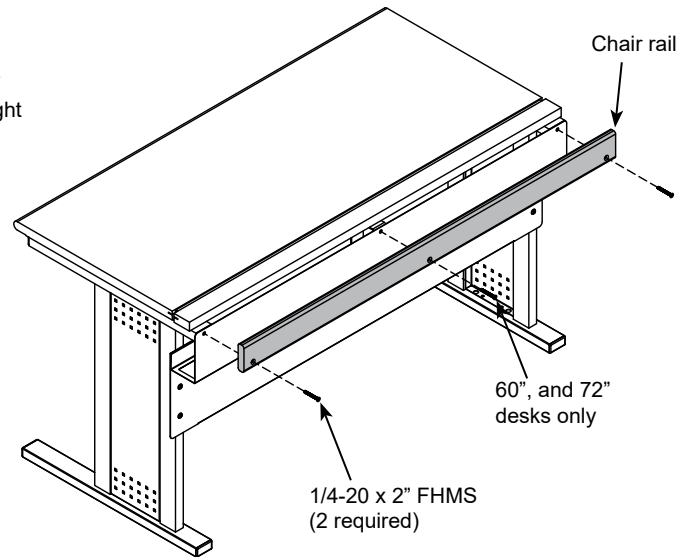

Figure 4.2

5 Attaching desks together (optional)

Two desks can be attached together with the included unit-to-unit bracket.

1. Locate the desks next to each other in their final position.
2. Attach the unit-to-unit bracket to the rear of the legs (behind cord channel) using the existing cord channel screws. (Loosen screws to install, then re-tighten).

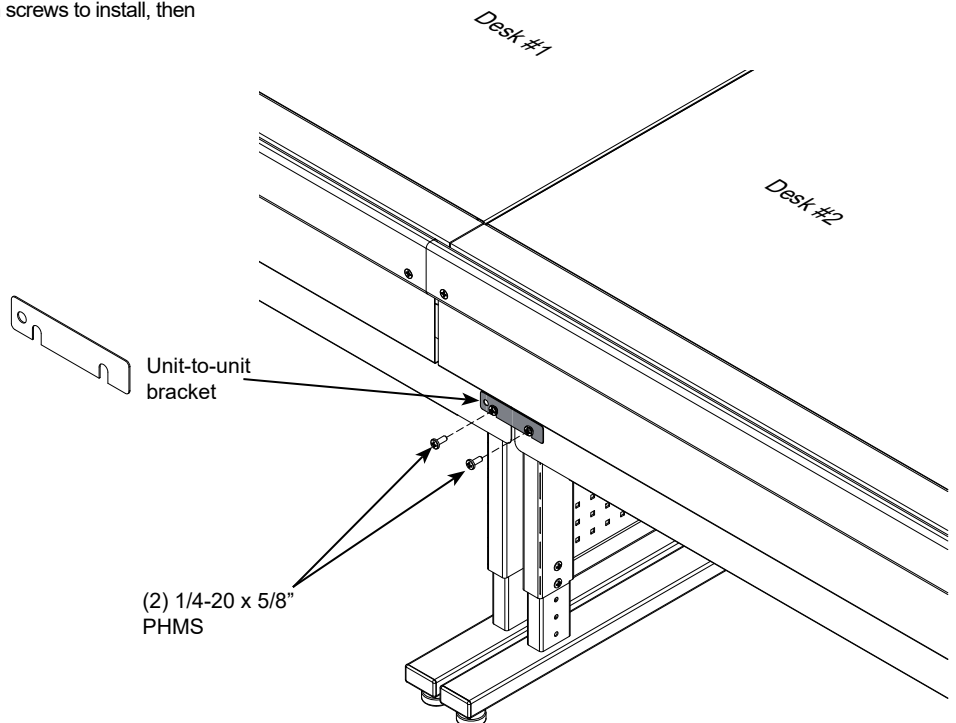

Figure 5

Warranty

We will make it right for you!

Thanks for choosing Spectrum! Spectrum is committed to provide complete customer satisfaction. Each of our products is manufactured from the best materials available and each product is stringently monitored throughout the production process through our P.A.C.E. program (Product Assurance to meet Customer Expectations).

We expressly warrant that Spectrum products will be of good quality and workmanship and free from defect for the period set out in the warranty from the date of delivery.

For a listing of all product specific warranty terms please visit our website at:

<https://www.spectrumfurniture.com/en/resources/purchasing-terms-warranty>

1-800-235-1262

Toll-free HELPLINE

spectrum@spectrumfurniture.com



Spectrum Industries is Certified ISO 9001:2015