

## Technical Specifications

30"D	24"D
Adjustable-Height 24-32"H	Adjustable-Height 24-32"H
38901ADJ - 36"W	38912ADJ - 36"W
38904ADJ - 60"W	38915ADJ - 60"W
38905ADJ - 72"W	38916ADJ - 72"W

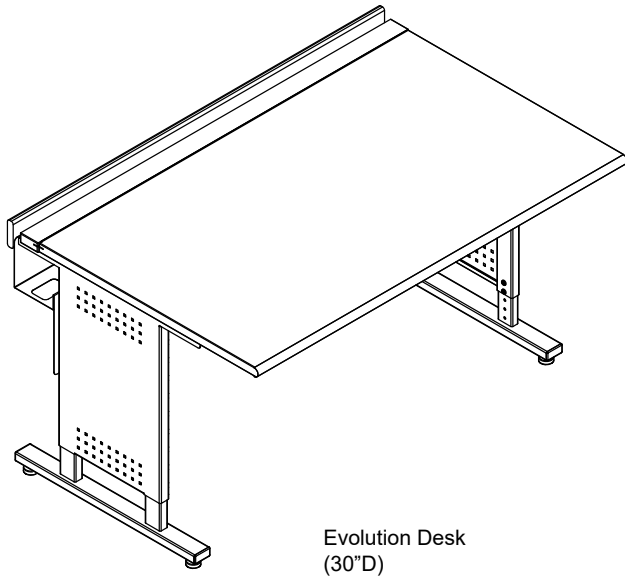

Evolution Desk  
(30"D)

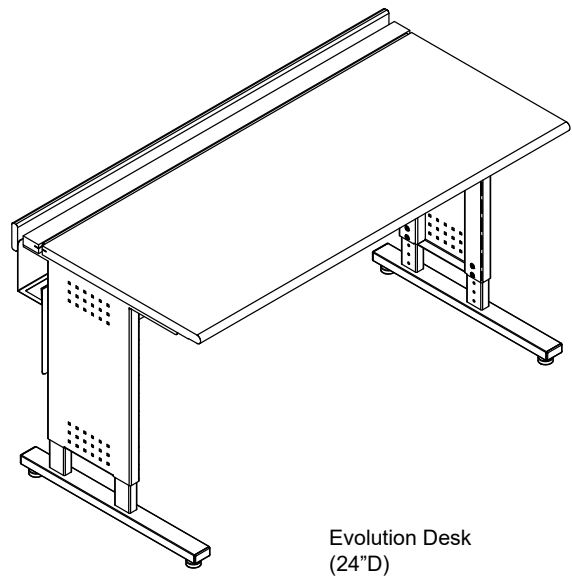

Evolution Desk  
(24"D)

*Designed for comfort, ergonomics, and durability, the Evolution computer desk is available in a variety of sizes to accommodate any room configuration. Adjustable height legs spaced to the edges maximize legroom. A bull-nose edge on the worksurface eliminates sharp corners to provide keyboarding comfort. A full-width cord channel and flip-top door safely routes cords out of sight while providing easy access. A wide variety of accessories including CPU slings, power options, and monitor arms provide functional options to outfit the desk to any environment. Backed by a 10 year warranty-the Evolution is the ultimate computer desk!*



## Features and Benefits

- Available in 24" or 30" deep versions
- Scratch and impact-resistant high-pressure laminate top provides a durable, useful worksurface
- Cord channel conveniently keeps computer wires and cables out of the way and is wide enough for most power strips
- Adjustable-height (ADJ) legs provide worksurface height adjustability
- Legs located at edges of desk maximize leg room
- Connectable worksurfaces and a wide variety of optional accessories allow easy adaptation to unique classroom environments
- Full-length flip-top door for easy cable and wire-access
- Solid oak chair rail protects wires and cables, and the back of the desk
- Steel modesty panel adds strength and stability
- Wider desks include hat-brace support to minimize flexing
- Leveling glides keep desk level on uneven surfaces
- User-friendly, bullnose radiused front edge on worksurface
- Attractive steel insert panels
- Desk ships "knocked-down" and can be assembled at the final location for easy installation and lower shipping costs
- Warranted to be free of all defects in materials and workmanship for 10 years
- Designed and assembled in Chippewa Falls, WI, USA

### Color Options



Wild Cherry / Black  
(CHB)



Graphite Talc /  
Dark Gray  
(GTD)



Bannister Oak / Putty  
(KP)

# Construction

- The worksurface is constructed from 1" thick composite board with high-pressure laminate on one face, and a balancing phenolic backer on the opposing face
- Left and right-side worksurface edges are finished with 3mm vinyl edgeband
- All metal components are finished with a scratch-resistant powder coat epoxy
- Worksurface support (60", and 72" desks only) is 14-gauge steel
- Formed 14-gauge steel legs
- Bottom leg rail includes weld-nuts for attaching glides or wheels
- 20-gauge cord channel/modesty panel and leg insert panels
- Chair rail is ¼ #1 select red oak, finished with a catalyzed top coat
- Post-formed bullnose on worksurface edge (student-side)
- Desks are shipped knocked-down (KD) and require assembly

# Specifications

Sizes available	<ul style="list-style-type: none"> <li>• 36"W [91 cm] x 24"D [61 cm]</li> <li>• 60"W [152 cm] x 24"D [61 cm]</li> <li>• 72"W [183 cm] x 24"D [61 cm]</li> </ul>	<ul style="list-style-type: none"> <li>• 36"W [91 cm] x 30"D [76.2 cm]</li> <li>• 60"W [152 cm] x 30"D [76.2 cm]</li> <li>• 72"W [183 cm] x 30"D [76.2 cm]</li> </ul>
Worksurface heights	• 24-32"H [61 - 81.3 cm] (adjustable in 1" increments)	
Cord channel	<ul style="list-style-type: none"> <li>• 3"D [7.6 cm] x 4.5"H [11.4 cm] (24"D)</li> <li>• 4.97"D [12.6 cm] x 4.5"H [11.4 cm] (30"D)</li> </ul>	
Worksurface heights available (top of worksurface)	24"-32"H [61 cm - 81.3 cm] in 1" [2.54 cm] increments	
Leg heights available	23"-31"H [58.4 cm - 78.7 cm] in 1" [2.54 cm] increments	
ADA-compliance*	 <ul style="list-style-type: none"> <li>• 1 ADA seat per table</li> </ul>	<p><i>*Minimum ADA guidelines for knee clearances are 30"W x 19"D x 27"H</i></p>
Certifications / Compliance	<ul style="list-style-type: none"> <li>• SCS Indoor Advantage Certified</li> <li>• TAA compliant</li> </ul>	• Meets or exceeds applicable ANSI-BIFMA test standards
Shipping weight (nominal)	<p style="text-align: center;"><b>30"D</b></p> <ul style="list-style-type: none"> <li>81 lb [36.8 kg] - 36"W x 30"D</li> <li>115 lb [52.2 kg] - 60"W x 30"D</li> <li>131 lb [59.5 kg] - 72"W x 30"D</li> </ul>	<p style="text-align: center;"><b>24"D</b></p> <ul style="list-style-type: none"> <li>75 lb [34 kg] - 36"W x 30"D</li> <li>109 lb [49.5 kg] - 60"W x 30"D</li> <li>127 lb [57.7 kg] - 72"W x 30"D</li> </ul>

Specifications subject to change without notice

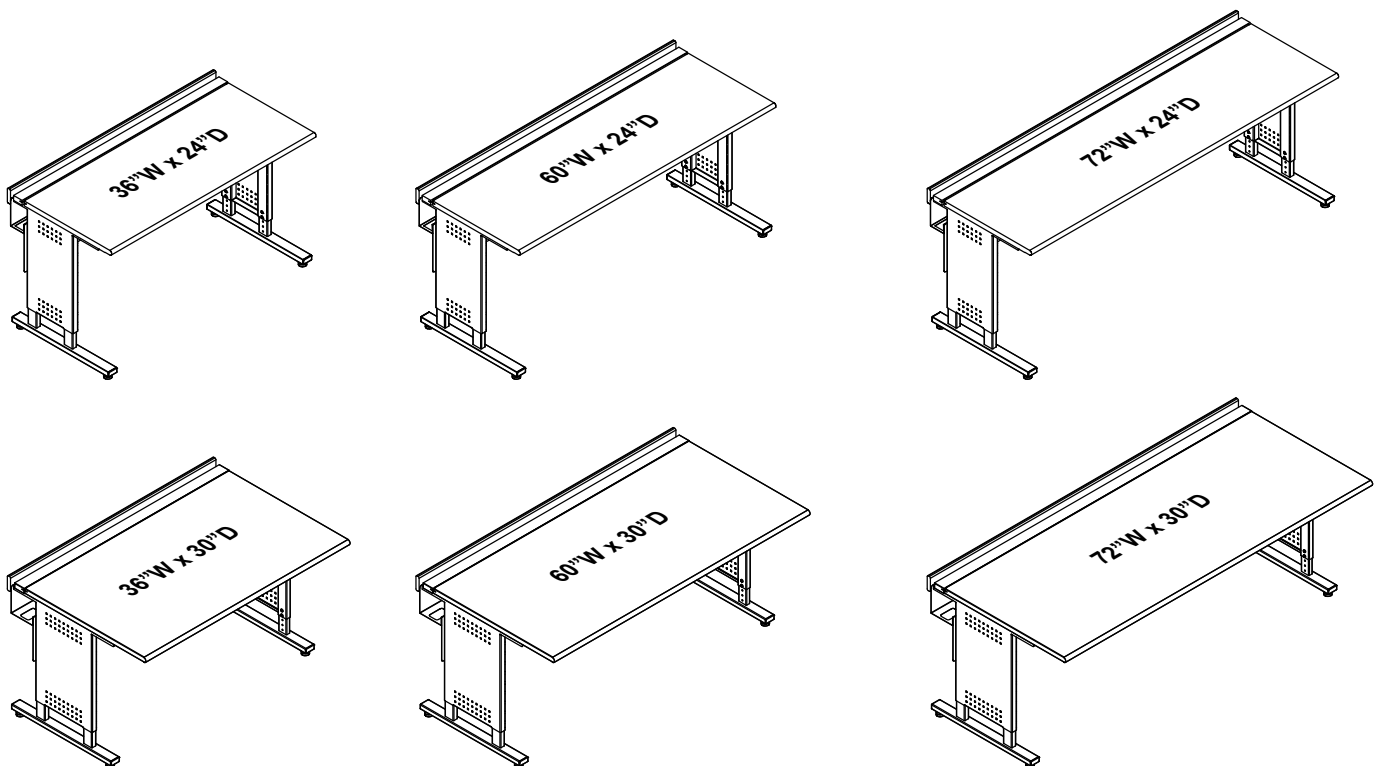

Evolution Desk (30"D)  
 (shown with optional 95500 CPU sling)

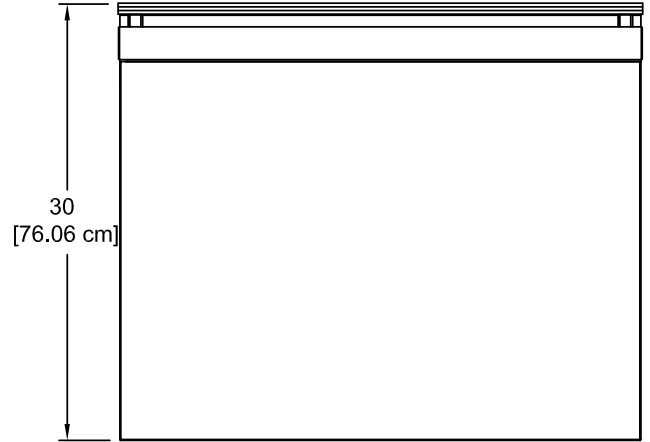
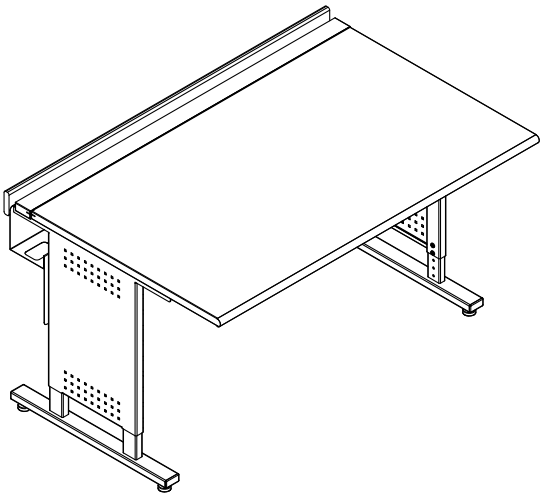

Bullnose edge on student-side

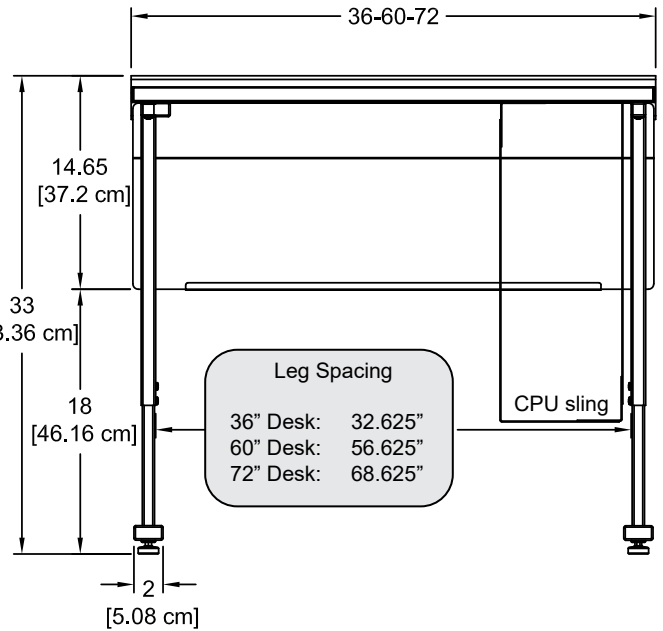
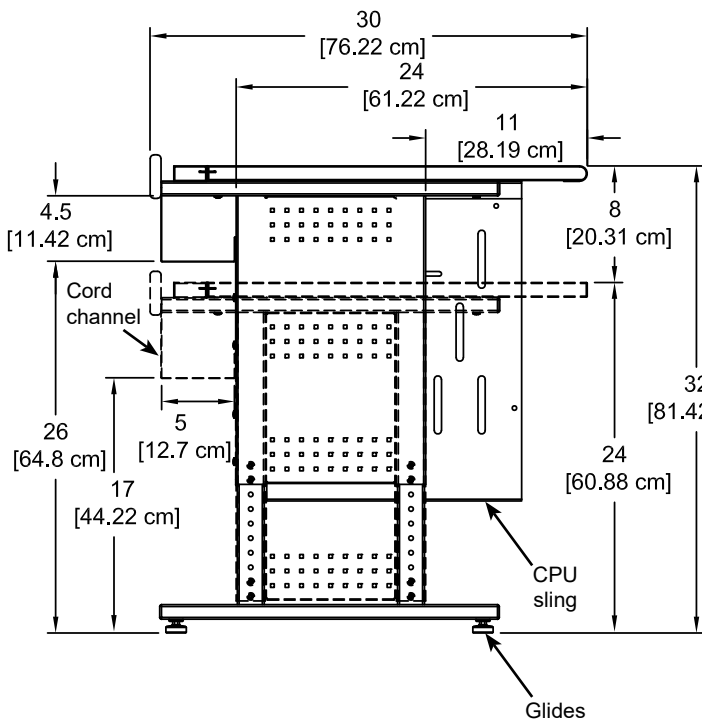

Leg Spacing	
36" Desk:	32.625"
60" Desk:	56.625"
72" Desk:	68.625"

Note: When determining leg spacing on Evolution desks with an optional CPU sling (95500 shown,) subtract 7.875", 8.875", or 9.875" (adjustable sling widths) from the leg spacing dimension. When using a narrow CPU sling, (95513) subtract 5"-to-8.5" (depending on width of CPU.)

Evolution Desk (24"D)  
 (shown with optional 95500 CPU sling)

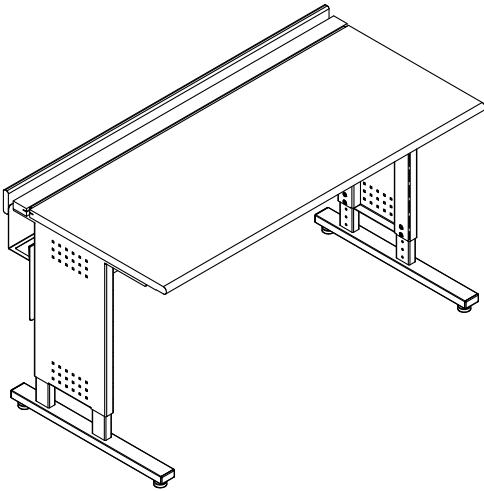

Bullnose edge on student-side

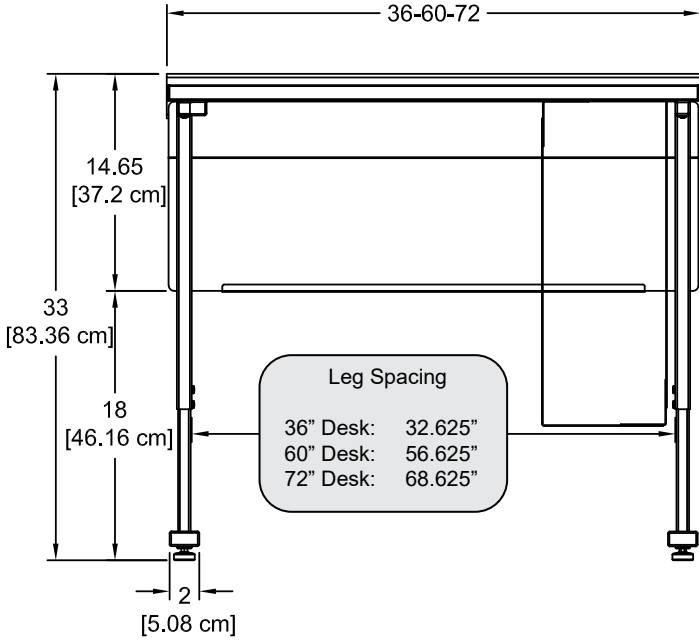
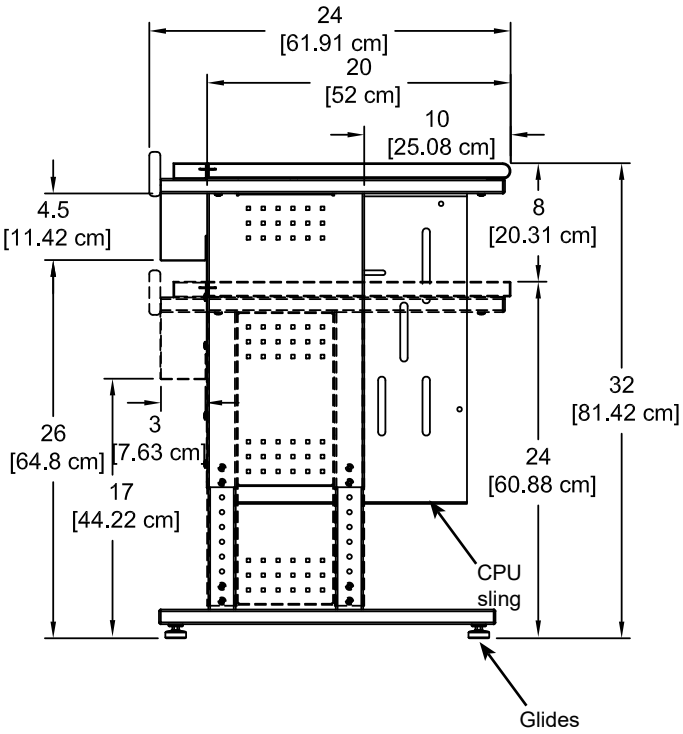

Note: When determining leg spacing on Evolution desks with an optional CPU sling (95500 shown,) subtract 7.875", 8.875", or 9.875" (adjustable sling widths) from the leg spacing dimension. When using a narrow CPU sling, (95513) subtract 5"-to-8.5" (depending on width of CPU.)

## Accessories

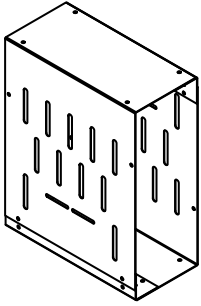

### Adjustable CPU Sling - 95500

- 8"-10"W x 17.5"D x 21"-23"H

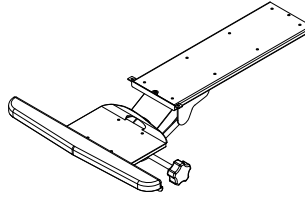

### Econo Keyboard Tray - 95520

- Platform: 18.375"W [46.67 cm]  
x 12"D [30.48 cm]
- Slide: 17.75"D [45.09 cm]

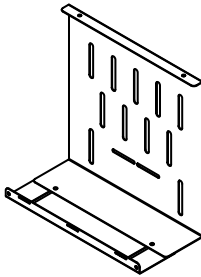

### Adjustable Narrow CPU Sling - 95513

- 5"-8.5"W x 18"D x 18"H

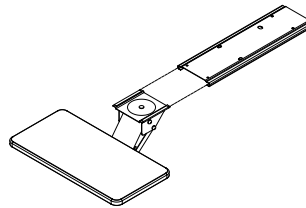

### Micro-arm Keyboard Tray - 95506

- Platform: 19.75"W [50.17 cm]  
x 10"D [25.4 cm]
- Slide: 17.75"D [45.09 cm]

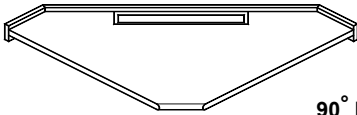

### 90° Inside Corner 30"D - 38906

### 90° Inside Corner 24"D - 38917

- Connects two Evolution desks together in a corner

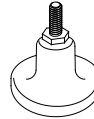

### 1" Bell Glide Riser Kit - 98513

- Raises worksurface height 1" [2.54 cm]
- 5/16-18 thread
- Set of 4
- Shipping weight: .5 lb [.23 kg]



### 7-Outlet Power Strip - 99024

- Electrical Rating: AC 125V, 15 Amps
- 1000 Joules surge capacity
- 12' Cord length
- LED switch
- UL Listed
- Shipping weight: 1.9 lb [.86 kg]



### Premium 3" Casters - 95042

- 3" diameter
- Provides desk mobility
- Two locking, two non-locking
- 5/16-18 x 3/4" threaded stem
- Raises overall desk height 2.75" compared to glides
- Not recommended for desks using unit-to-unit brackets

Note: Casters cannot be installed on adjoining desks connected with unit-to-unit brackets, as interference will occur between casters. Before installing casters, any unit-to-unit brackets need to be removed- this will result in a small gap between adjoining desks.



### Flat Panel Monitor Arm

**95512** - for monitors weighing 2-13 lb

**95522** - for monitors weighing 7.5-25 lb

**95509** - for monitors weighing 12-31 lb

- Six mounting options (clamp, thru-desk, wall, grommet hole, side bolt, reverse wall)
- Compatible with all VESA® monitors - includes 75mm and 100mm VESA® adapters
- Cable management concealed in arm



### Dual Flat Panel Monitor Arm - 95533

- Weight range: 3.5-13 lb per monitor
- Six mounting options (clamp, thru-desk, wall, grommet hole, side bolt, reverse wall)
- Compatible with all VESA® monitors - includes 75mm and 100mm VESA® adapters
- Cable management concealed in arm



### Multi-Weight Monitor Arm

**95539** - without USB & multimedia ports

**95540** - with USB & multimedia ports

- Adjustable gas spring counterbalance
- Weight range: 2.2-33lb
- Fits most 17-35" monitors
- Quick-release 75mm, 100mm, VESA® mounting plate
- Clamp or grommet mounting
- Optional (2) USB 3.0 ports and (2) 3.5mm jacks for mic / headphones
- Cable management channel

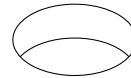
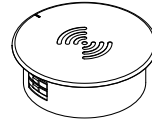

### EM Wireless Charging Pad - 99057

- Uses electromagnetic technology to charge Qi V1.2 compliant IC devices ("Qi" enabled)
- LED to confirm pairing / charging
- Security tab prevents theft
- Requires 3" round cutout to be made by customer
- UL-certified

Note: The unit requires a 7" diameter of clearance to work with Qi-enabled phones placed in any orientation. The 3" dia cutout should be located on the worksurface at least 3.5" from any edge.

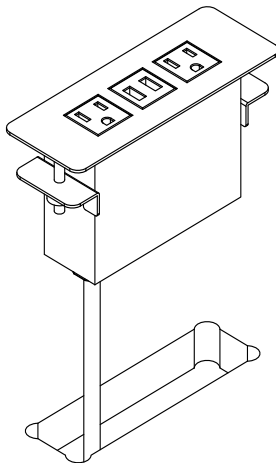

### Power Module - 99058

- (2) AC power receptacles
- (2) USB charge ports
- Aluminum housing and flange
- Thumbscrew clamps
- Requires worksurface cutout
- ETL-certified
- Available in black, silver, or white
- Customer-installed

Cutout required:	5.65"W [14.35 cm] x 1.65"D [4.19 cm]
Power cord:	10' [305 cm] 14AWG *3C power cord
Power receptacles:	125V, 60hz, 15A tamper-resistant
USB charging ports:	2.1A (10.5W) (not data-compatible)
Dimensions:	6.38"W [16.2 cm] x 2.36"D [6 cm] x 3.54"H [9 cm]
Unit weight:	2 lb [.9 kg]
Shipping weight:	2.35 lb [1 kg]

### Single Circuit Power Kits

(Plugs into 3-prong AC wall outlet)

3-prong  
AC plug

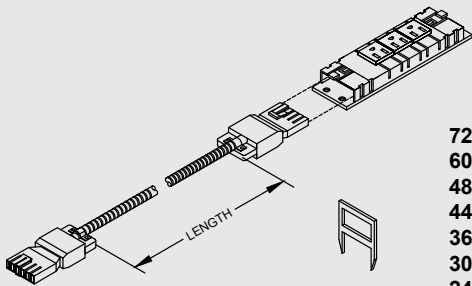

- 72" - 99063
- 60" - 99064
- 48" - 99065
- 44" - 99066
- 36" - 99067
- 30" - 99068
- 24" - 99069

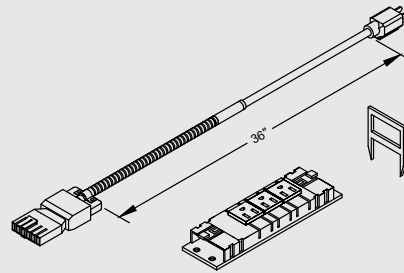

### Single Circuit Power Feed - 99070

with 36" flexible cord and 3-prong AC plug

### EP8 Kits

Provides isolated ground circuits  
(requires hard-wiring)

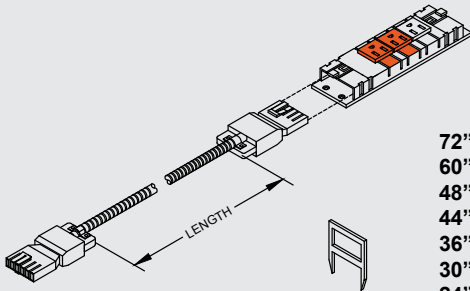

- 72" - 99011
- 60" - 99010
- 48" - 99018
- 44" - 99009
- 36" - 99008
- 30" - 99014
- 24" - 99013

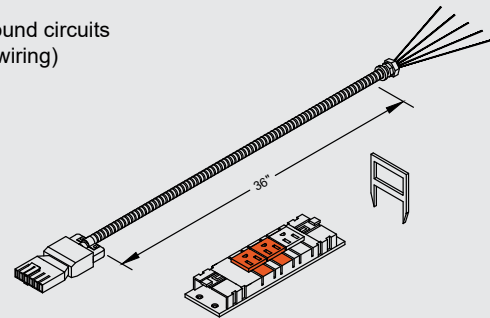

### Base Power Feed - 99022

with 36" flexible cord

See [spectrumfurniture.com](http://spectrumfurniture.com) for the latest accessories and detailed warranty information.

## Warranty

### **We will make it right for you!**

Thanks for choosing Spectrum! Spectrum is committed to provide complete customer satisfaction. Each of our products is manufactured from the best materials available and each product is stringently monitored throughout the production process through our P.A.C.E. program (Product Assurance to meet Customer Expectations).

We expressly warrant that Spectrum products will be of good quality and workmanship and free from defect for the period set out in the warranty from the date of delivery.

**For a listing of all product specific warranty terms please visit our website at:**

<https://www.spectrumfurniture.com/en/resources/purchasing-terms-warranty>

**1-800-235-1262**

Toll-free HELPLINE

**[spectrum@spectrumfurniture.com](mailto:spectrum@spectrumfurniture.com)**