

CORE Lectern™

55548	CORE (no cutouts)
55549	CORE (used with worksurface cutouts)
55550	Outer laminate panels

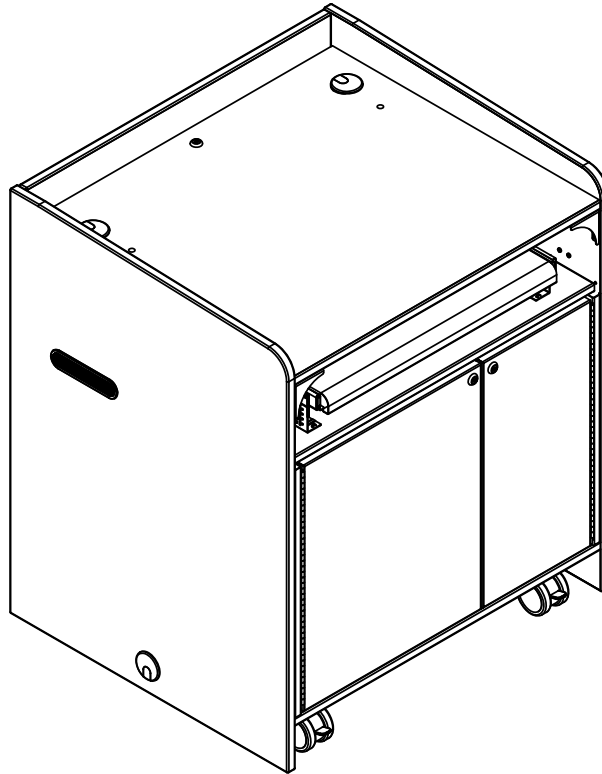

Important	Important	Importante
<p>Before using this product:</p> <ul style="list-style-type: none"> • Read this manual • Comply with all safety and operating instructions • Ensure all parts and correct quantities are included <p>Any parts damaged during shipment must be reported within 5 days of receipt. To report information regarding missing parts or damage, to purchase parts or accessories, or if you have any questions, please contact us.</p> <p>Thank you for purchasing Spectrum products!</p>	<p>Avant d'utiliser ce produit:</p> <ul style="list-style-type: none"> • Veuillez à lire ce guide • Respectez les consignes de sécurité et d'utilisation • Vérifiez que vous disposez de toutes les pièces nécessaires à l'installation <p>Les pièces endommagées pendant le transport doivent faire l'objet d'un rapport dans les 5 jours de leur réception. Veuillez prendre contact avec nous si des pièces manquent ou sont abîmées, si vous avez des questions, ou encore pour acheter des pièces ou des accessoires.</p> <p>Merci pour votre achat d'un produit Spectrum!</p>	<p>Antes de utilizar este producto:</p> <ul style="list-style-type: none"> • Lea este manual • Cumpla con todas las instrucciones de prevención de accidentes y operativas • Revise que todas las partes y las cantidades correctas estén incluidas <p>Si alguna parte se dañó durante el embarque, deberá reportarla en un lapso de 5 días a partir de la recepción. Para reportar cualquier información sobre partes faltantes o dañadas, para adquirirlas o comprar accesorios, o bien, si tiene alguna duda, póngase en contacto con nosotros.</p> <p>¡Gracias por adquirir productos Spectrum!</p>



<http://www.spectrumfurniture.com>

Owner's Manual Le manuel du propriétaire El manual del propietario	Specs Spécifications Especificaciones	Video Vidéo Vídeo
--	---	-------------------------



800-235-1262

Components

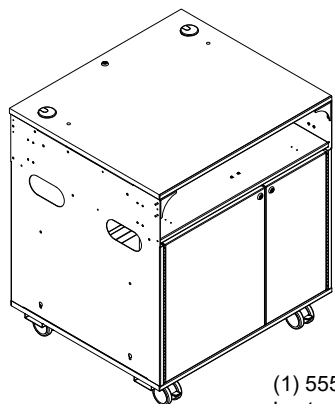

(1) 55548 / 55549
Lectern CORE

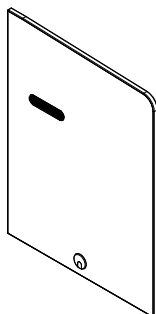

(1) Left side
panel

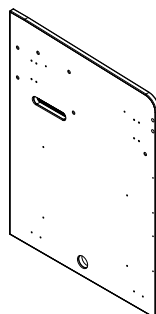

(1) Right side
panel

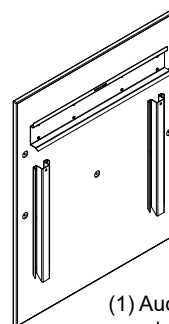

(1) Audience-side
panel

Keyboard tray

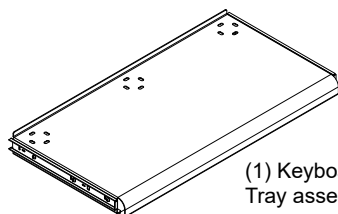

(1) Keyboard
Tray assembly



(8) 0100167
8-32 x 1/2" PH
thread-cutting
screw

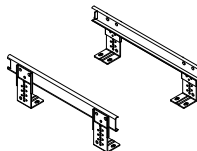

(1pr) 050092
12" Slide set
(bracket screws
included)



(8) 029019
8-32 Locknut

Tools



X2



$\frac{3}{16}$ " Drill with $\frac{3}{16}$ " drill bit

$\frac{1}{4}$ " Drill with $\frac{1}{4}$ " drill bit



Assembly tip: Do not tighten component fasteners completely until all have been installed. Keeping them loose will help with alignment between parts during assembly.

1 Attach side panels to lectern CORE

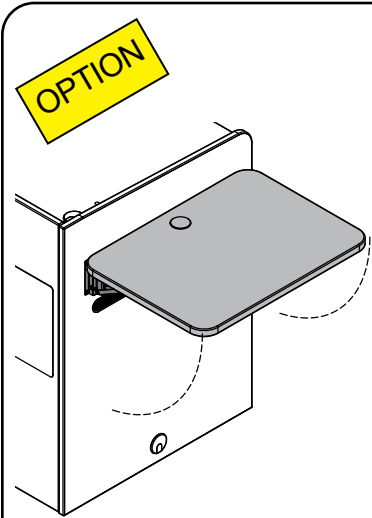

Drill side panel(s) for flip-up shelf

If you have an optional flip-up shelf, the (8) starter holes on the back of the laminate side panel need to be drilled through before installing. If you don't have a flip-up shelf, continue with side panel attachment below.

Tip: Masking tape can be used on the laminate-side to minimize chip-out.

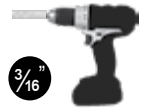

Drill with 3/16" drill bit

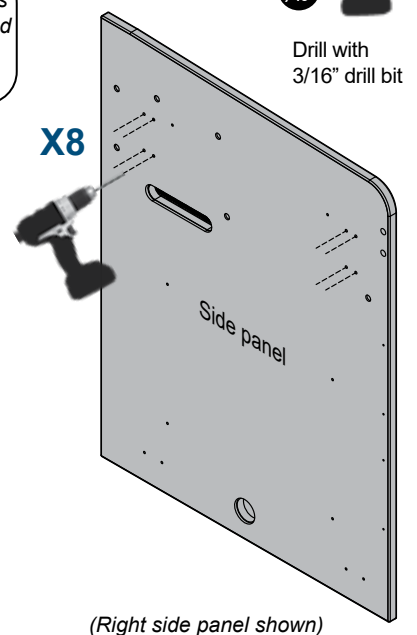

(Right side panel shown)

1. Determine which panel the shelf will be mounted (left or right side)
2. Locate the (8) starter holes in the back of the side panel.
3. Using a drill with a 3/16" drill bit, slowly drill completely through the panel at the (8) hole locations.
4. Continue with side panel attachment below.

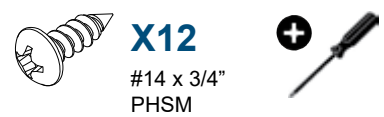
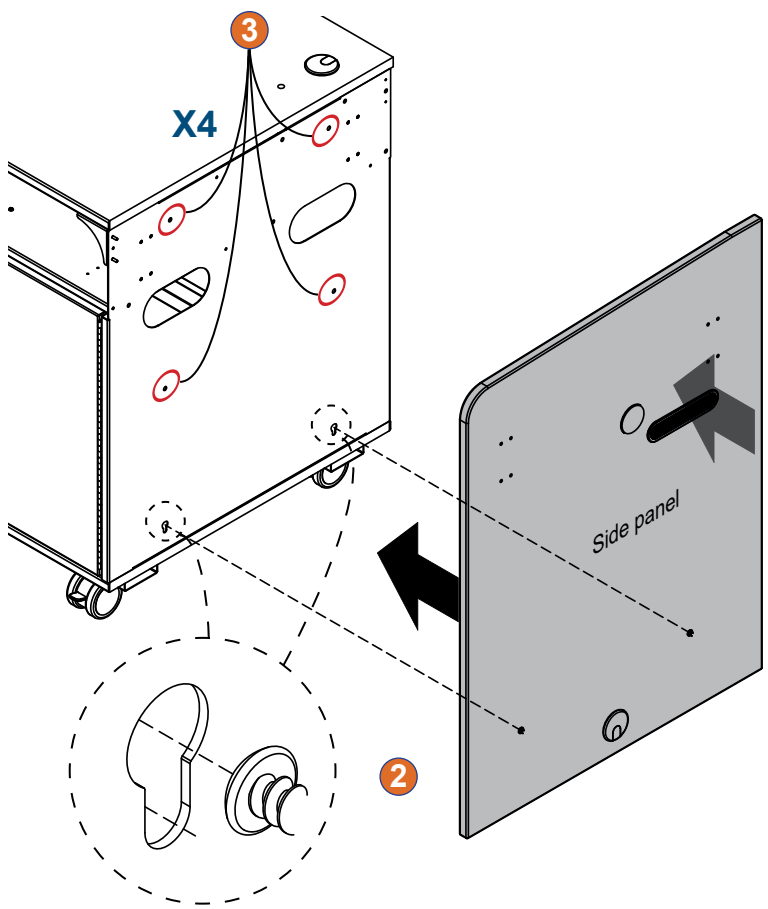

X12
#14 x 3/4"
PHSM

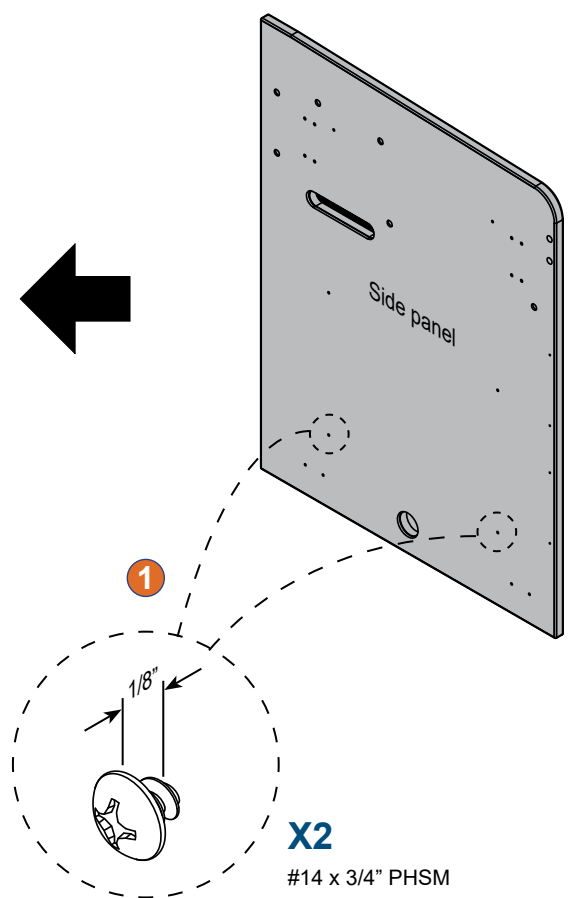

X2
#14 x 3/4"
PHSM

1. Insert pre-installed panel screws into the keyholes and push side panel onto CORE.
2. Secure side panel to CORE by tightening the (6) pre-installed screws from the inside.
3. Repeat for the other side panel.

2 Attach optional flip-up shelf



Remove pre-installed adapters
(Not used on CORE Lectern)

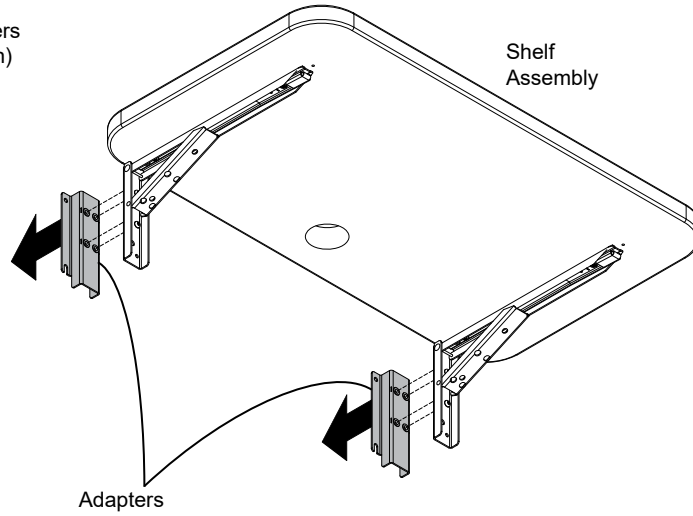

Install flip-up shelf:

1. Align the shelf brackets and spacer plates with the drilled holes.
2. Secure using **(8) 8-32 x 1-1/2" PHM screws** and on the inside, **(8) 3/16" flat washers**, and **(8) 8-32 Keps nuts**.
3. Tighten fasteners securely.
4. Install 2" grommet in shelf.

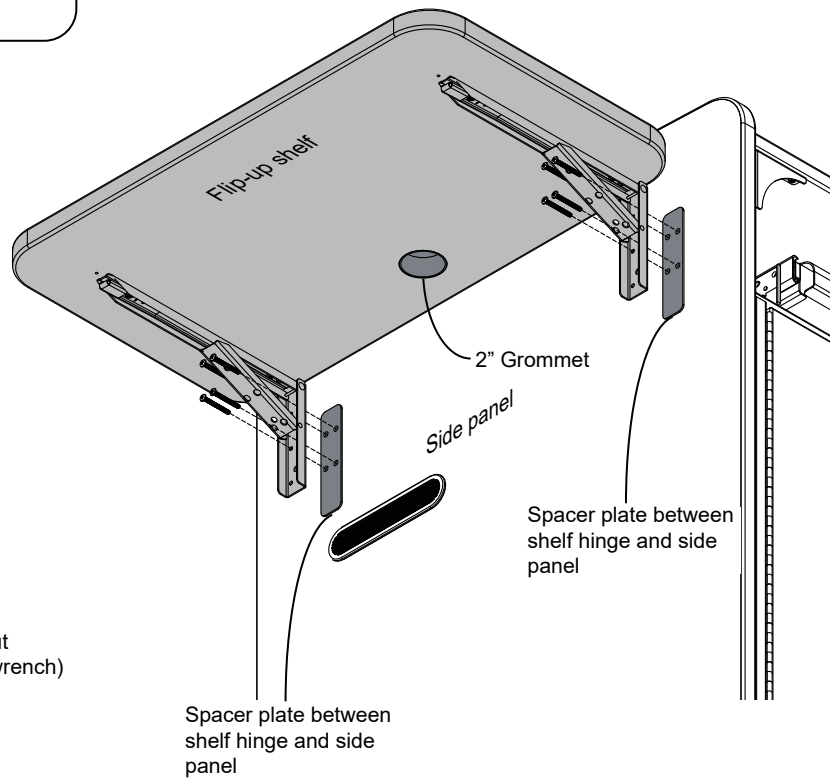
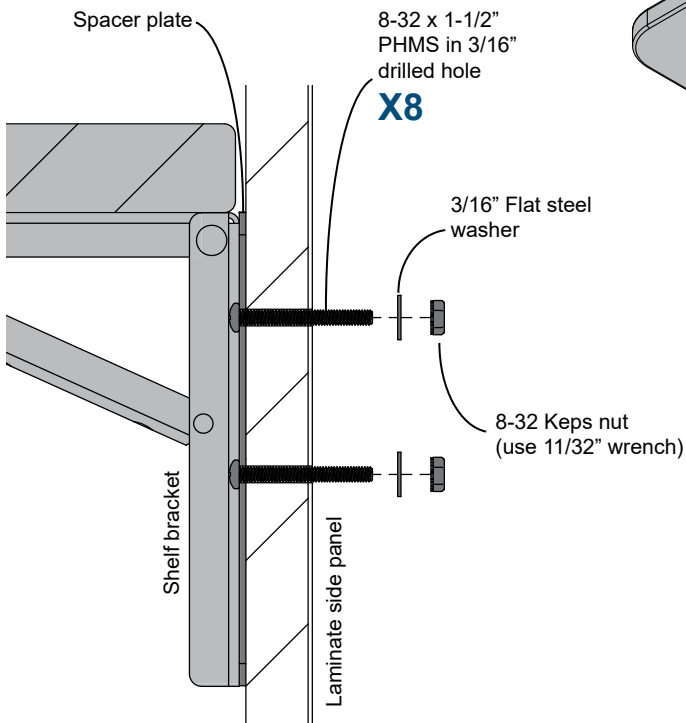

3 Attach audience-side panel to lectern CORE

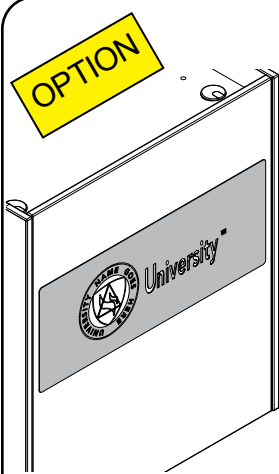

OPTION

Drill audience-side panel for logo panel

If you have an optional logo panel, the (6) starter holes on the back of the laminate side panel will need to be drilled through before installing. If you don't have a logo panel, continue with audience-side panel installation below.

Tip: Masking tape can be used on the laminate-side to minimize chip-out.

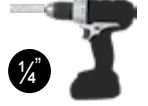

Drill with 1/4" drill bit

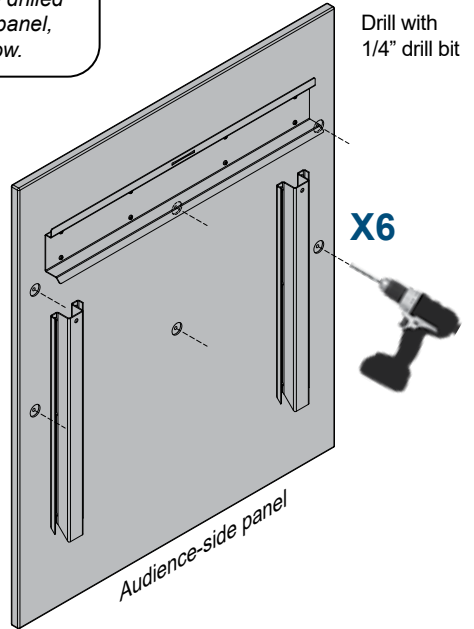

1. Locate the (6) starter holes in the back of the audience-side panel.
2. Using a 1/4" drill bit, slowly drill completely through the panel at the 6 hole locations.
3. Align the logo panel studs with the drilled holes and secure with (6) 1/4" washers and (6) 10-32 keps nuts.
4. Continue with logo and audience-side panel installation below.



Note: Using key, turn lock cam 90° counterclockwise before installing the audience-side panel, then lock after panel is in place.

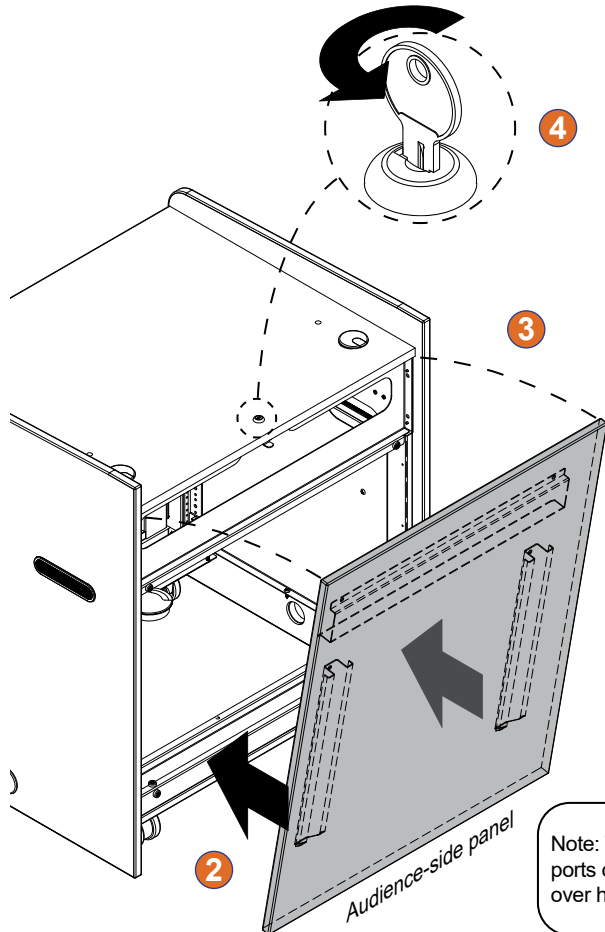

- X6** 10-32 Keps nuts
- X6** 1/4" Flat washers

Note: The two metal channel supports on audience-side panel "hook" over horizontal bracket on CORE.

4 Attach slide brackets

1. Attach the 'L' brackets to each outer slide with screws (included with slides). The brackets will be attached "inboard" (facing each other).

Multiple height positions / mounting holes are available with the brackets-use the same hole position on all four brackets.

2. Tighten the bracket screws securely.

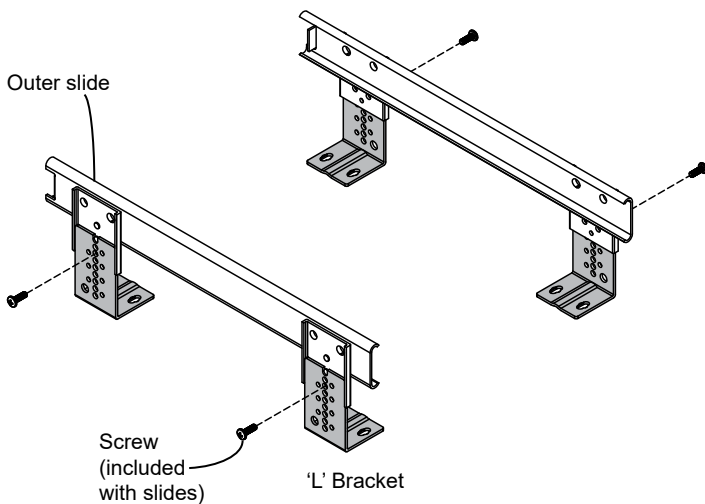

5 Attach slide assemblies to mid panel

1. Align and attach the left and right slide assemblies with 8-32 x 1/2" PH thread-cutting screws, but do not tighten completely.

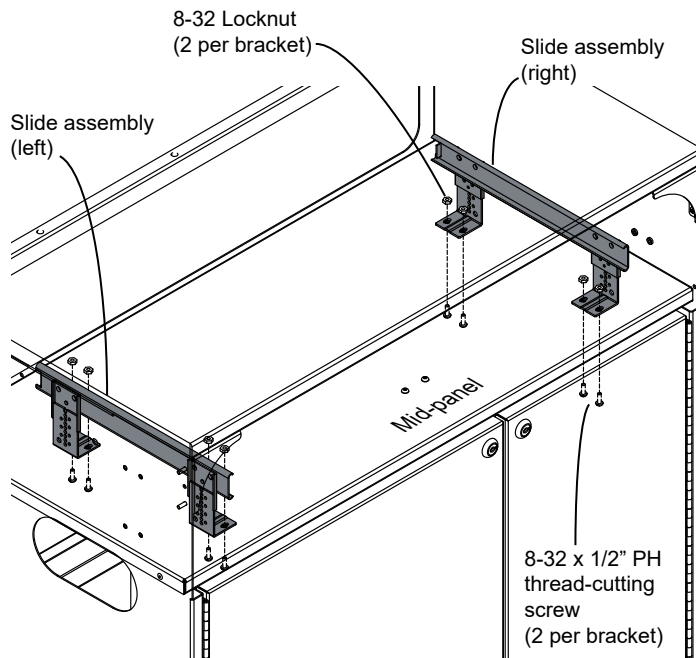

6 Install keyboard tray

1. Slide the keyboard tray into the slides and push all the way in until two clicks are heard.

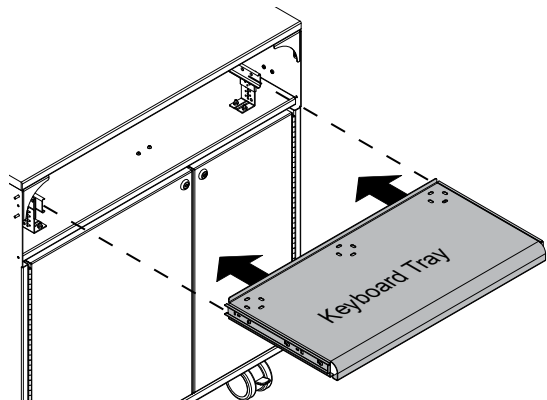

Removing keyboard tray

1. To remove the tray from the slides, locate the plastic lever on each slide
2. Release the levers on the both slides while pulling the tray out

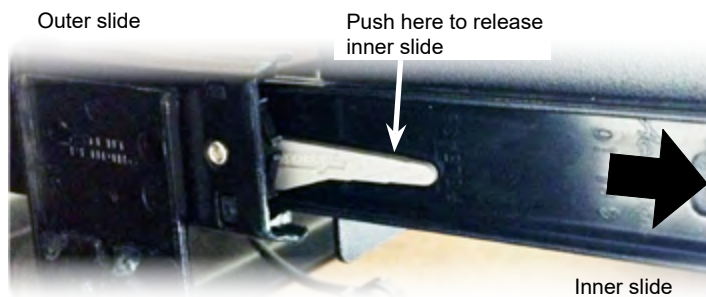

7 Locking casters

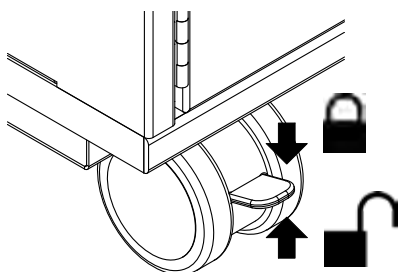

Accessories

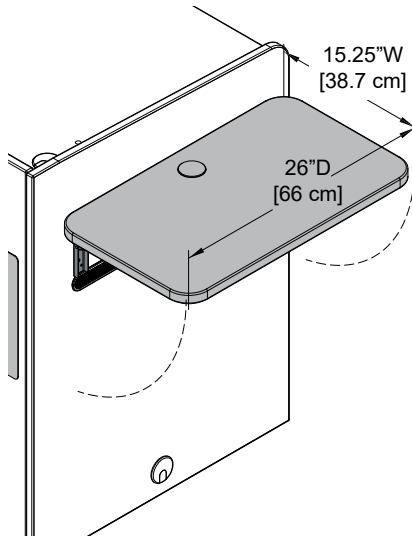

Flip-Up Shelf - 55540

- Matching laminate
- 15.25\"W [38.7 cm] x 26\"D [66 cm] x 1\"H [2.54 cm]
- Shelf brackets lock into place in the upright position
- Includes 2\" grommet
- 35 lb [15.9 kg] weight capacity
- Also available with White Chalk Dry Erase laminate. When configured with white laminate, flip-up shelves will have the same edgeband color as the outer panels.
- Customer-installed

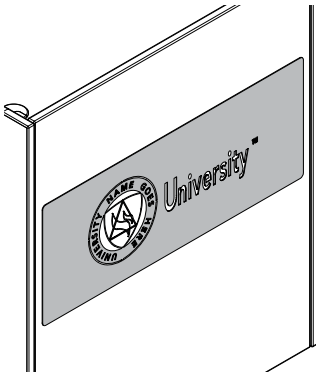

Customized Logo Panel - 55199

- Attaches to audience-side
- Available with black, white, matching, or printed laminate backer
- To get panel customized-contact Spectrum for details
- New logos require a first time logo charge
- Customer-installed

Dimensions:	30\"W [76.2 cm] x 12\"H [30.48 cm]
Available logo area:	28\"W [71.1 cm] x 10\"H [25.41 cm]
Unit weight:	6 lb [2.7 kg]
Shipping weight:	8 lb [3.6 kg]

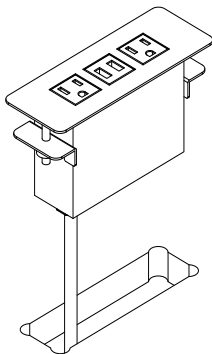

Power Module - 99060

- (2) AC power receptacles
- (2) USB charge ports
- Aluminum housing and flange
- Thumbscrew clamps
- Requires worksurface cutout
- ETL-certified
- Available in black, silver, or white
- Customer-installed

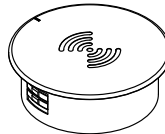

EM Wireless Charging Pad - 99057

- Uses electromagnetic technology to charge Qi V1.2 compliant IC devices ("Qi" enabled)
- LED to confirm pairing / charging
- Security tab prevents theft
- Requires 3\" round cutout to be made by customer
- UL-certified

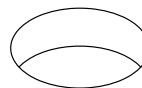

Note: The unit requires a 7\" diameter of clearance to work with Qi-enabled phones placed in any orientation. The 3\" dia cutout should be located on the worksurface at least 3.5\" from any edge.



See spectrumfurniture.com for complete details on Spectrum's full line of monitor arms.



7-Outlet Power Strip - 99024

- Electrical Rating: AC 125V, 15 Amps
- 1000 Joules surge capacity
- 12' cord length
- LED switch
- UL Listed
- Shipping weight: 1.9 lb [.86 kg]

See spectrumfurniture.com for the latest accessories and detailed warranty information.



Important Safety & Care Information



- Read these instructions before assembly or operation.
- Do not allow children to move the lectern.
- Proceed slowly and carefully when moving the lectern.
- For indoor use only. Do not install or store the lectern where it will be exposed to moisture.
- Do not block the ventilation openings.
- Avoid uneven loading of the equipment into the lectern. Uneven weight distribution could cause the lectern to tip when the lectern is moving.
- Do not allow anyone to sit, stand, or climb on the lectern.
- Use a damp, soft-cloth, or sponge, with mild soap or detergent solution to clean dirty surfaces. Do not use harsh solvents or abrasives.
- This lectern is intended for institutional use. It does not have any user-serviceable parts or user-maintenance requirements. If servicing is necessary, please contact Spectrum Industries for assistance.

Warning - Relocating audio and/or video equipment to furniture not specifically designed to support audio and/or video equipment may result in death or serious injury due to the furnishing collapsing or over turning onto a child.

Warning - Death or serious injury may occur when children climb on audio and/or video equipment furniture. A remote control or toys placed on the furnishing may encourage a child to climb on the furnishing and as a result the furnishing may tip over on to the child.

Electrical Safety:

- Do not plug the power cord into an extension cord.
- Inspect power cords for damage before each use. Do not use power cords that are damaged.
- Unplug power cord from electrical outlet by gripping the cord. Do not unplug the power cord by pulling only on the cord.
- Do not step on, drive over, drag, or place objects on the power cord.
- For added safety, plug the lectern into a grounded outlet controlled by a GFI (Ground Fault Interrupter) circuit breaker.
- Electrical devices are not toys. Children are often unaware of the hazards associated with electrical devices. This lectern must always be used by adults or with adult supervision.

Warranty

We will make it right for you!

Thanks for choosing Spectrum! Spectrum is committed to provide complete customer satisfaction. Each of our products is manufactured from the best materials available and each product is stringently monitored throughout the production process through our P.A.C.E. program (Product Assurance to meet Customer Expectations).

We expressly warrant that Spectrum products will be of good quality and workmanship and free from defect for the period set out in the warranty from the date of delivery.

For a listing of all product specific warranty terms please visit our website at:

<https://www.spectrumfurniture.com/en/resources/purchasing-terms-warranty>

1-800-235-1262

Toll-free HELPLINE

spectrum@spectrumfurniture.com