

Assembly Instructions

⚠ Important ⚠

Before you begin, read and comply with all safety and operating instructions, and ensure all parts and correct quantities are included.

Any parts damaged during shipment must be reported within 5 days of receipt. To report information regarding missing parts or damage, to purchase parts or accessories, or if you have any questions, please contact us.

www.spectrumfurniture.com
800-235-1262, 715-723-6750

Thank you for purchasing Spectrum products!

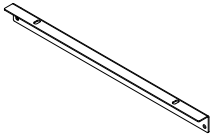

(1) 0109102
Stepped Height
Bracket



(4) 052605
1/4-20 x 15mm JC bolt



(1) 025039
4mm Hex wrench

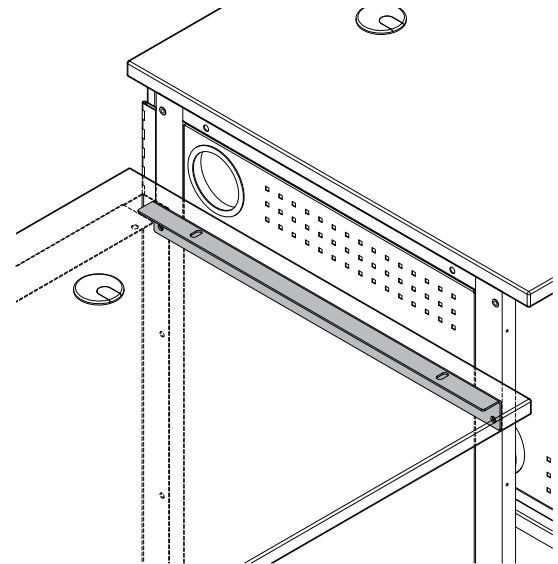

Stepped-Height Bracket for IMC

68205

Tools
Required



4mm Hex
wrench
(included)

1. Install Bracket to Equipment Rack

1. Before installation, assemble and attach the lower (29"H) wall filler panels, equipment racks and any end-support or mid-support legs. **The adjacent wall filler panel will need to be attached to the 36" equipment rack before the bracket is installed.**
2. Align the bracket with the (2) mounting holes in the side of the 36"H equipment rack as shown. **Figure 1.**
3. Attach with (2) 1/4-20 x 15mm JC Bolts, and tighten securely.

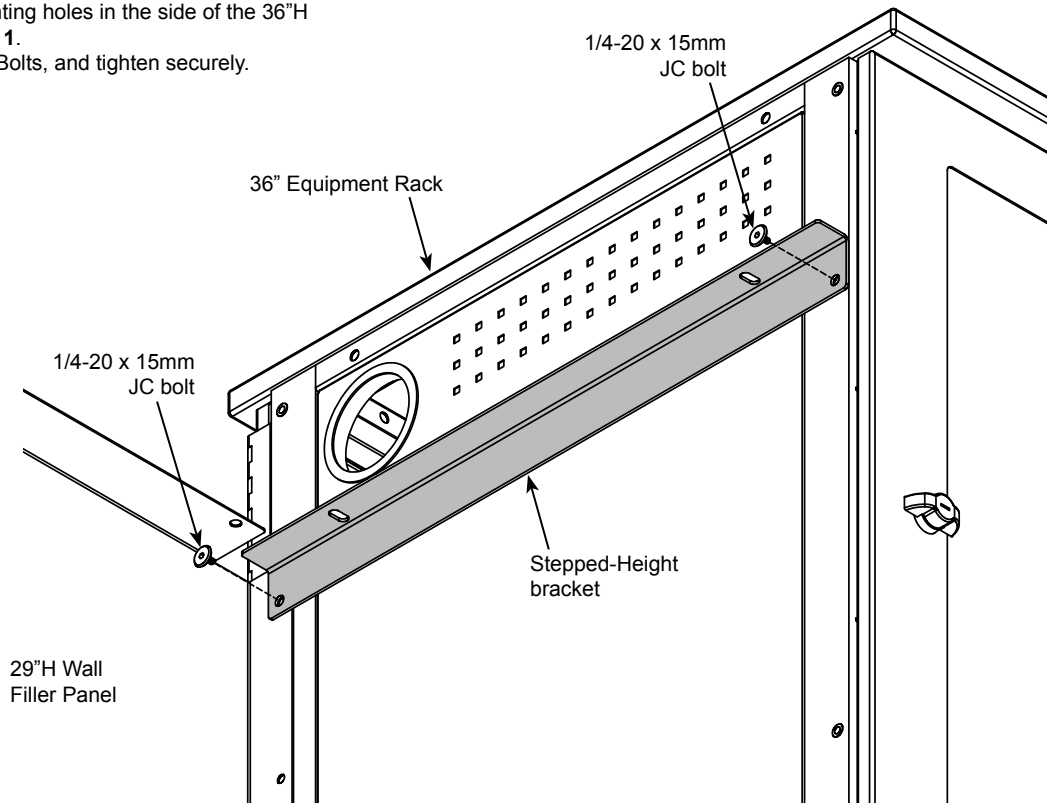

Figure 1

2. Install Worksurface

1. Set the work surface onto the installed 29" wall filler panel(s) and the stepped-height bracket as shown in **Figure 2**.
2. Align the mounting holes and attach the work surface to the bracket with (2) 1/4-20 x 15mm JC bolts.

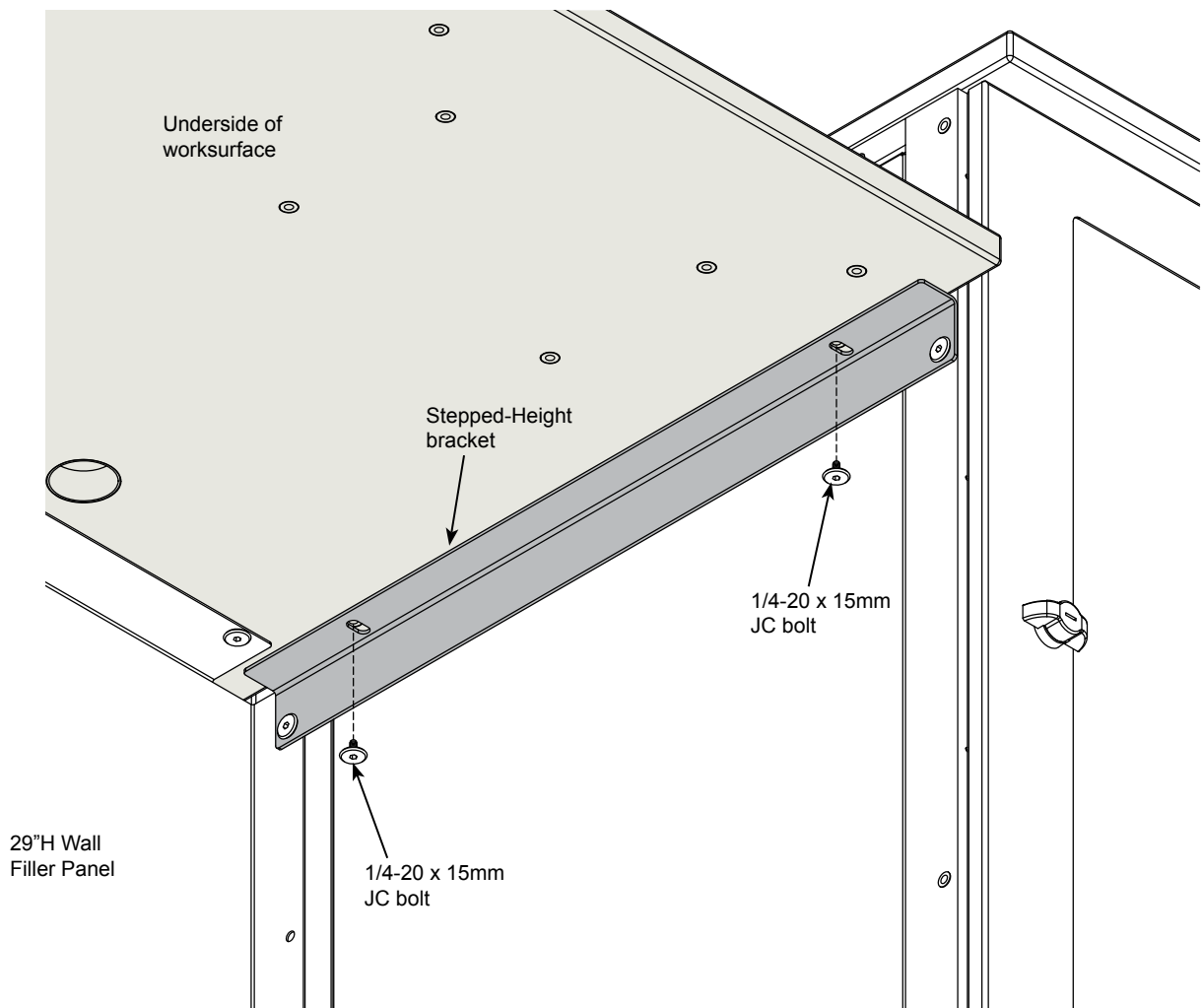

Figure 2