

Technical Specifications

55394

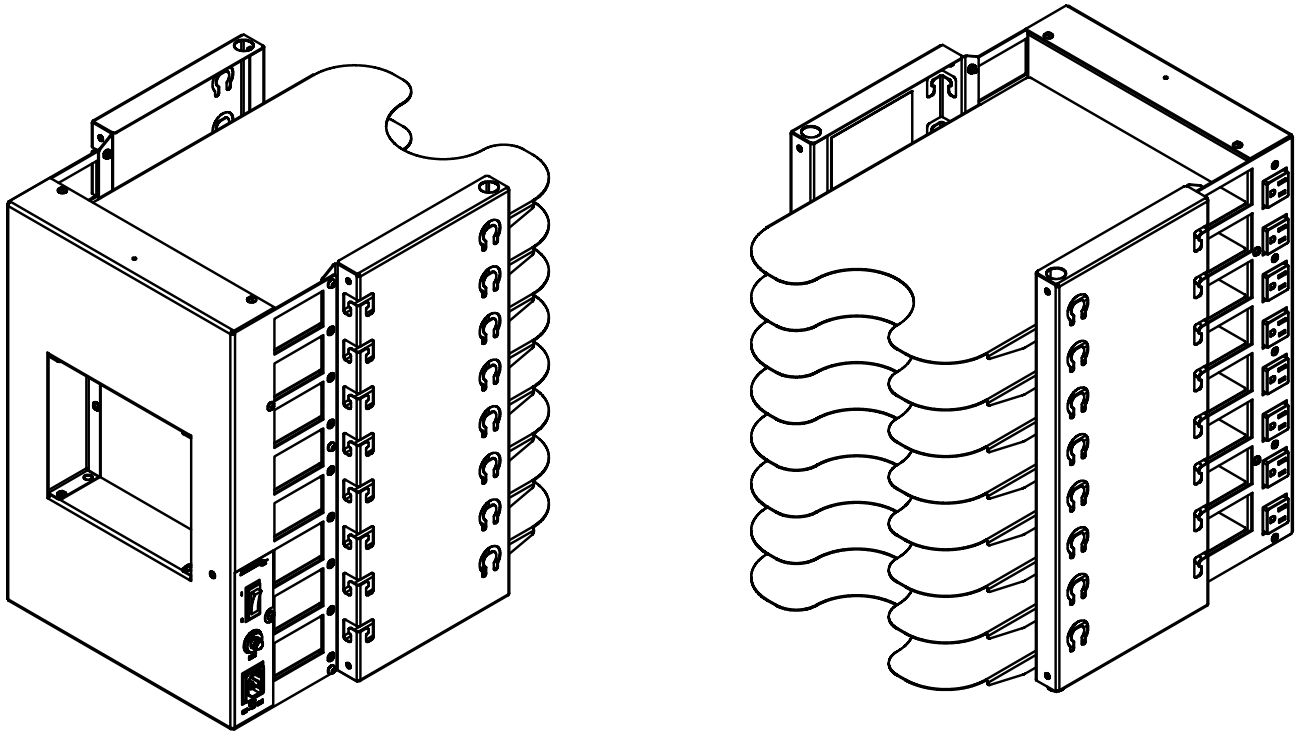

Use the Collectiv8™ Charging Pillar to store and charge up to 8 devices (most tablets, Chromebooks™, and notebooks). Wiring slots keep cords organized and speed wiring to each bay. The Collectiv8 Pillar's small footprint covers less counter space, and is made with powder-coated steel for durability.



Features and Benefits

- Stores and charges up to 8 devices (most tablets, Chromebooks™, and notebooks)
- 11"W [27.94 cm] x 14.933"D [37.93 cm] x 1.964"H [5 cm] storage bay
- Durable 16ga steel trays
- Unit can be anchored to a floor, permanent worksurface or wall for additional stability and security
- A second unit can be stacked and secured to the first using the optional stacking kit (Fasteners for concrete applications are provided)
- Wiring slots keep cords organized and speed wiring to each bay
- 8-outlet, surge-suppressed power unit
- Optional Stacking Kit connects two Collectiv8 units together and secures to worksurface or floor
- Optional Wall Hanging Kit attaches one Collectiv8 unit to a wall
- Optional Wall Shroud provides ADA-compliance by extending Collectiv8 profile to floor
- Optional Power Module provides single-circuit charging to multiple charging pillars
- Ships fully-assembled for quick, simple integration and deployment
- Durable powder coated steel chassis provides a long lasting finish
- Warranted to be free of all defects in materials and workmanship for 10 years, electrical system 2 years
- Designed and assembled in Chippewa Falls, WI, USA

Color Options

Chassis:



Warm Gray

Shelves:



Spectrum Blue

Construction

- Metal components consist of 16-gauge steel
- 16-gauge side panels, and sheaves
- All metal components are finished with a scratch-resistant powder coat epoxy
- Each Collectiv8 Charging Pillar is factory-assembled

Specifications

| | | |
|-----------------------------|---|---|
| Capacity | 8 devices | |
| Bay capacity (nominal) | <ul style="list-style-type: none"> • 11"W [27.94 cm] x 14.933"D [37.93 cm] x 1.964"H [5 cm] • Max weight per shelf : 5 lb [2.27 kg] | |
| Electrical | <ul style="list-style-type: none"> • (8) 120V 3-prong plug outlets • ON / OFF switch (red illuminated) • Power Input: 110-240VAC | <ul style="list-style-type: none"> • Load capacity: 15A, 1800 watts • 15A replaceable fuse • 8' [243.8 cm] nominal 3-wire IEC power cord |
| Certifications / Compliance | <ul style="list-style-type: none"> • cUL listed | <ul style="list-style-type: none"> • Meets or exceeds applicable ANSI-BIFMA test standards |
| Unit weight (nominal) | 27 lb [12.3 kg] | |
| Shipping weight (nominal) | 34 lb [15.4 kg] | |

Specifications subject to change without notice

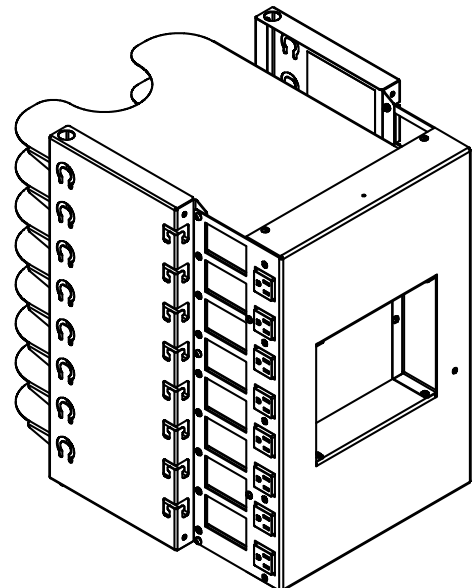
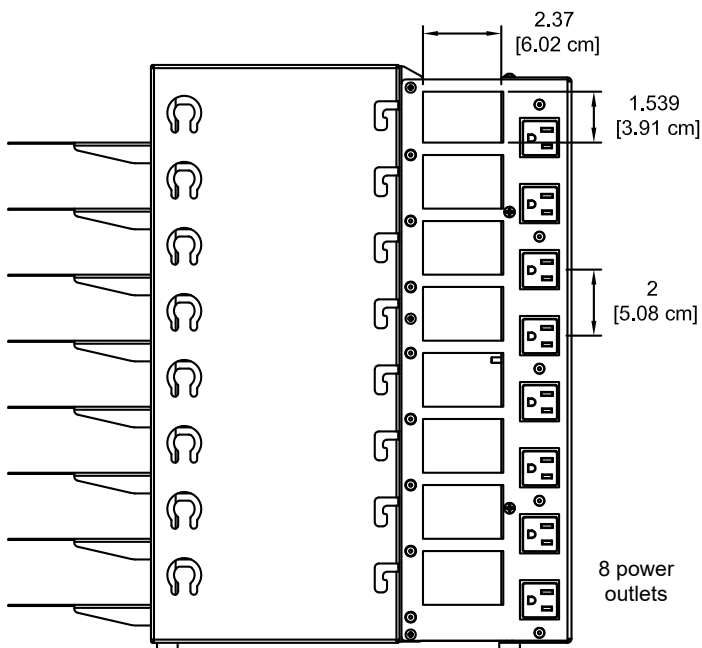
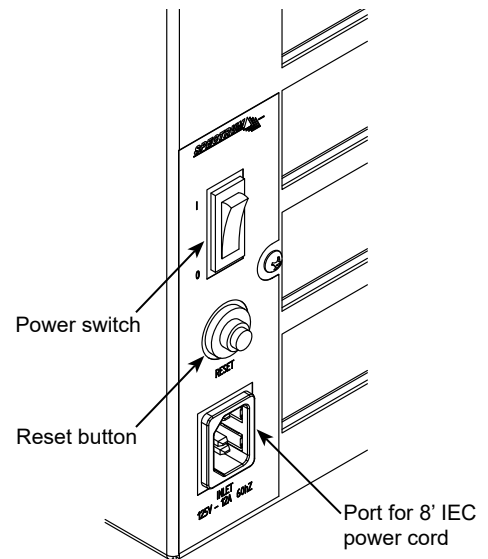
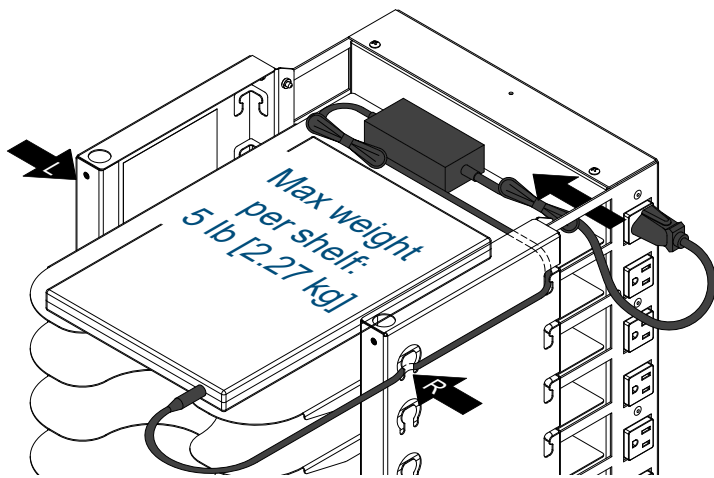

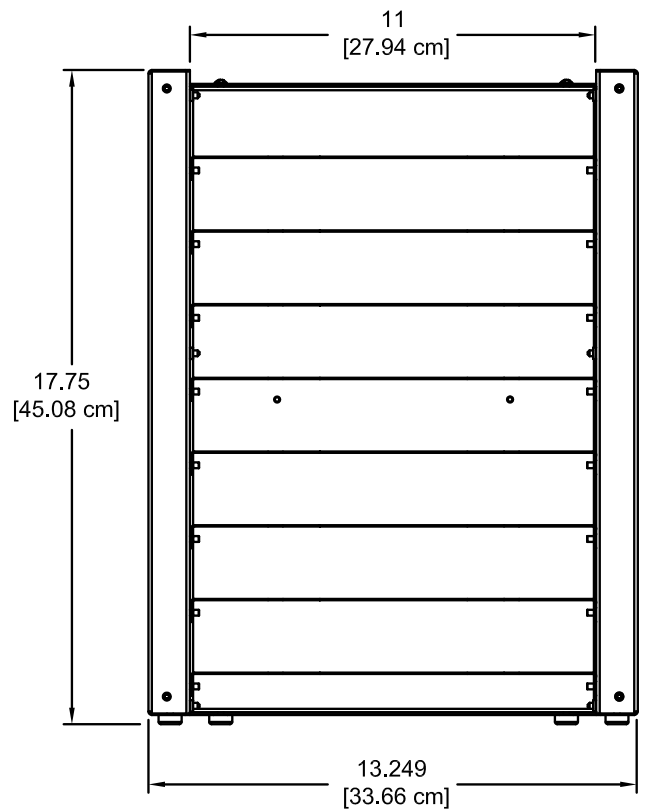
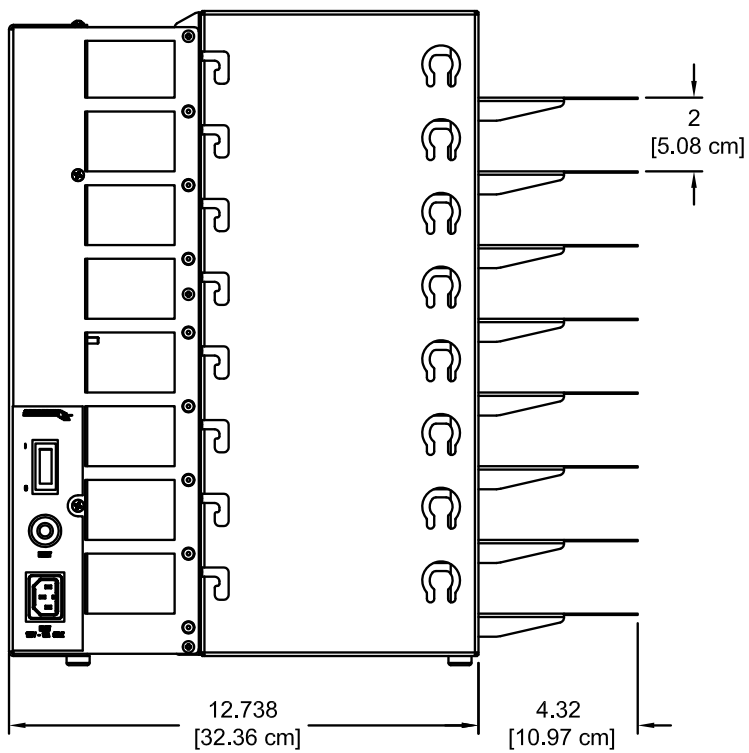
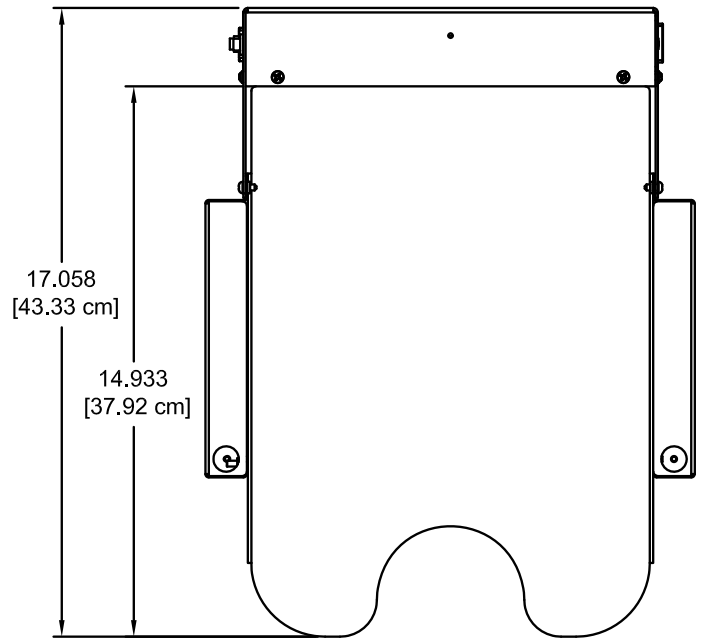
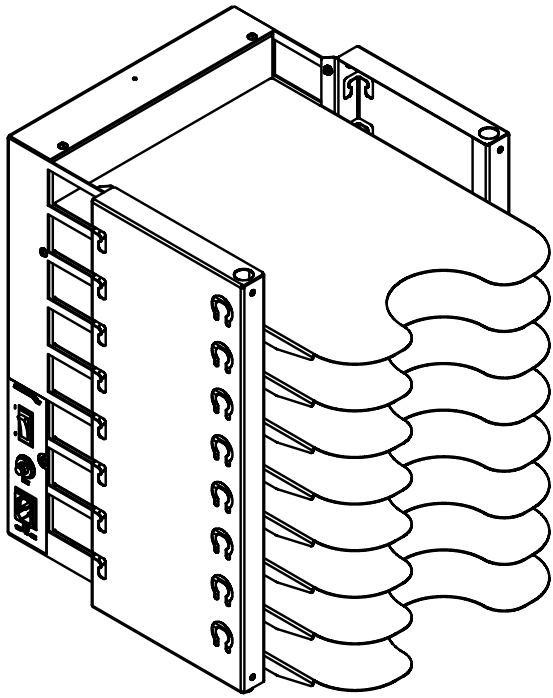

Accessories



Power Module

- w/ Power switch - 55397
- w/ eLogix™ timer (2-bank) - 55398
- w/ PowerProdigy™ timer (4-bank) - 55399

- Provides single-circuit charging to multiple Collectiv8 Charging Pillars
- The Power Module can be installed between or below a stack of Collectiv8 Charging pillars
- Includes AC power cord (1m)
- If wall mounting, (1) Wall Hanging Kit is still required for each Collectiv8 unit
- 13.249"W x 12.378"D x 4"H

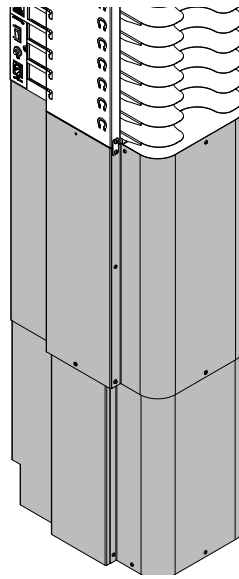

Wall Shroud - 55415

- Provides ADA-compliance by extending profile of wall-mounted Collectiv8 unit 27" or higher off floor
- Telescoping adjustability from 24.75-46"H
- 16ga steel
- Attaches to Collectiv8, floor, and wall
- Baseboard clearance
- (1) Wall Hanging Kit is also required for each Collectiv8 unit

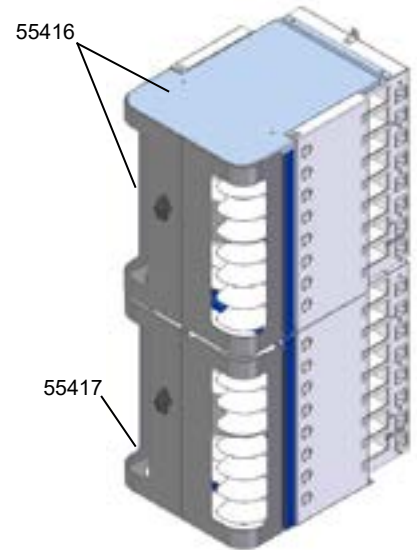

Security Door Kit with top panel - 55416 Security Door Kit - 55417

- Locking doors provide device security
- 55416 door kit with top panel (for single units, or upper unit when stacked)
- 55417 door kit only (for lower unit when stacked)

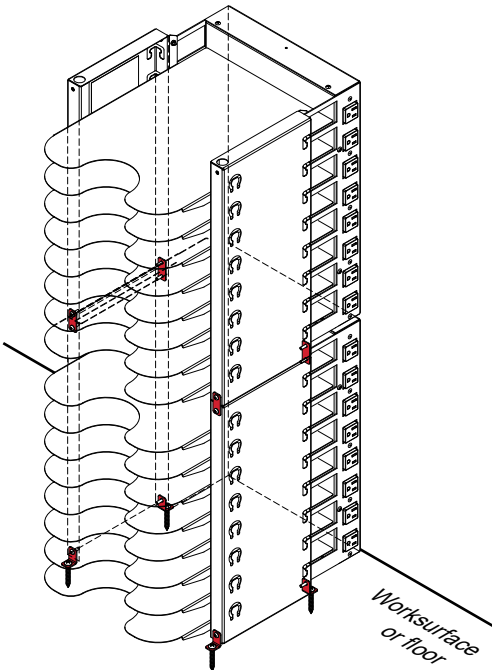

Stacking Kit - 55395

- 55395 Stacking Kit connects two Collectiv8 Charging Pillars together and secures them to a work surface or floor
- Max recommended stack height: 2 units
- Fasteners included for concrete floor applications

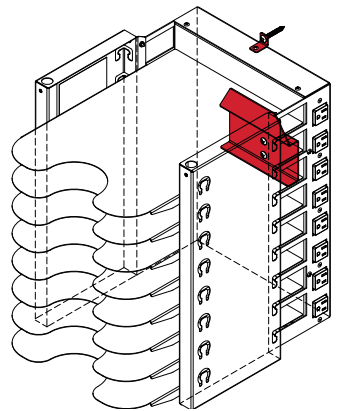

Wall Hanging Kit - 55396

- (1) 55396 kit will attach one unit to a wall
- Fasteners included for concrete wall applications
- To fully comply with ADA guidelines, it's recommended the unit be hung above base cabinets or other permanent structure that extends to the floor

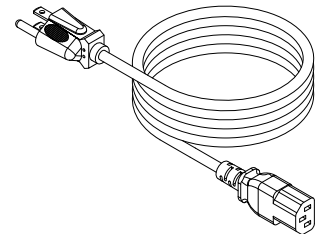

3ft Power Cord - 99056

- 14ga wire rated at 300V
- 3' long IEC power cord
- NEMA plug rated at 125V
- RoHS certified

See spectrumfurniture.com for the latest accessories and detailed warranty information.

Warranty

We will make it right for you!

Thanks for choosing Spectrum! Spectrum is committed to provide complete customer satisfaction. Each of our products is manufactured from the best materials available and each product is stringently monitored throughout the production process through our P.A.C.E. program (Product Assurance to meet Customer Expectations).

We expressly warrant that Spectrum products will be of good quality and workmanship and free from defect for the period set out in the warranty from the date of delivery.

For a listing of all product specific warranty terms please visit our website at:

<https://www.spectrumfurniture.com/en/resources/purchasing-terms-warranty>

1-800-235-1262

Toll-free HELPLINE

spectrum@spectrumfurniture.com



Spectrum Industries is
Certified ISO 9001:2015