

Assembly Instructions

⚠ Important ⚠

Before you begin, read and comply with all safety and operating instructions, and ensure all parts and correct quantities are included.

Any parts damaged during shipment must be reported within 5 days of receipt. To report information regarding missing parts or damage, to purchase parts or accessories, or if you have any questions, please contact us.

www.spectrumfurniture.com
800-235-1262, 715-723-6750

Thank you for purchasing Spectrum products!

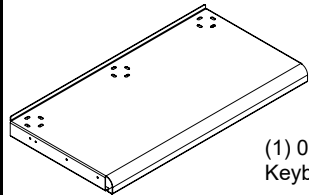

(1) 0140345
Keyboard Tray



(14) 0100167
8-32 x 1/2" PH
thread-cutting
screw

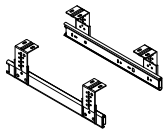

(1pr) 050092
12" Slide set



(8) 037542
#8 x 5/8" PHSM



(8) 029019
8-32 Locknut

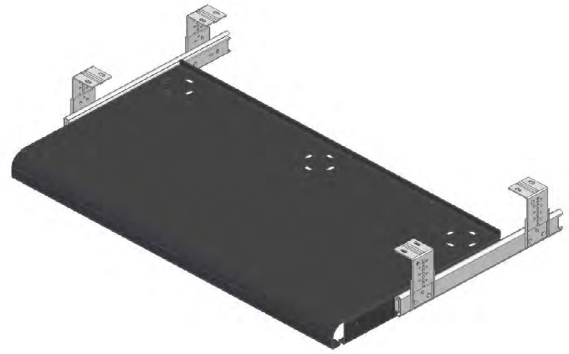

Pull-out Keyboard Tray 55496

Note: For CORE Lectern installations only, (12 8-32 x 1/2" PH thread-cutting screws, (8) #8 x 5/8" PHSM screws and (8) 8-32 locknuts are used.

1. Assemble slide brackets

1. Attach the 'L' brackets to each outer slide with screws (included with slides). The brackets need to be attached "inboard" (facing each other). **Figure 1.**
 - For Freedom XRS / CORE Lecterns, multiple height positions / mounting holes are available with the brackets-use the same hole position on all four brackets.
 - For Pivot Premiere Lecterns, use the tallest position on all four brackets.
2. Tighten the bracket screws securely.
3. Separate the inner from the outer slides using the black levers.
4. Raise the lectern up all the way and unplug the power cord.

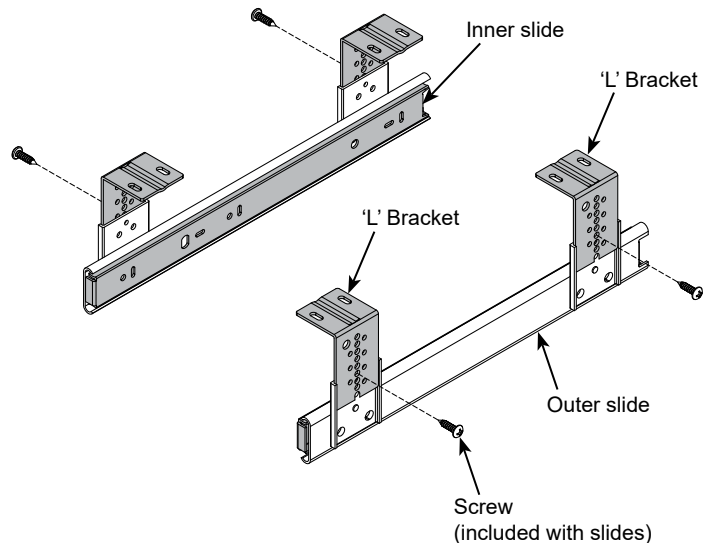

Figure 1

Note: On Freedom XRS and Pivot Premier installations, the 'L' brackets can be adjusted to provide varied keyboard heights-the keyboard tray may protrude up to a maximum of 3.9" [10 cm] below the worksurface. If the lectern is used for ADA use, a higher adjusted worksurface will be necessary to provide ADA leg clearance.

2. Attach inner slides to tray

Freedom XRS / CORE Lecterns:

1. Attach each inner left and right slide to the keyboard tray with (3) 8-32 x 1/2" PH thread-cutting screws and tighten securely. **Figure 2.1**

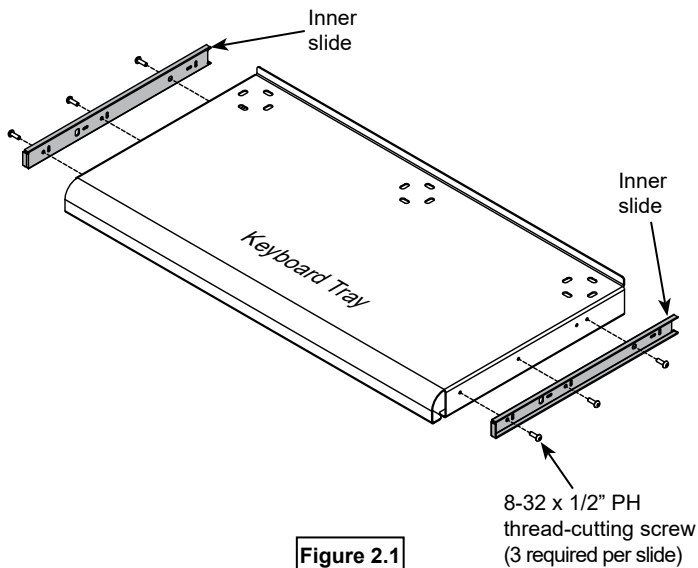

Figure 2.1

Pivot Premier

1. Slides mounted in rear position. Attach each inner left and right slide to the keyboard tray with (2) 8-32 x 1/2" PH thread-cutting screws and tighten securely. **Figure 2.2**

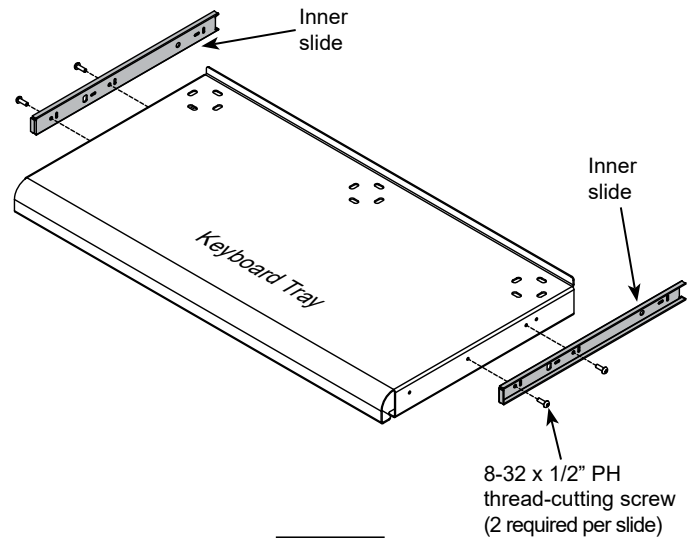
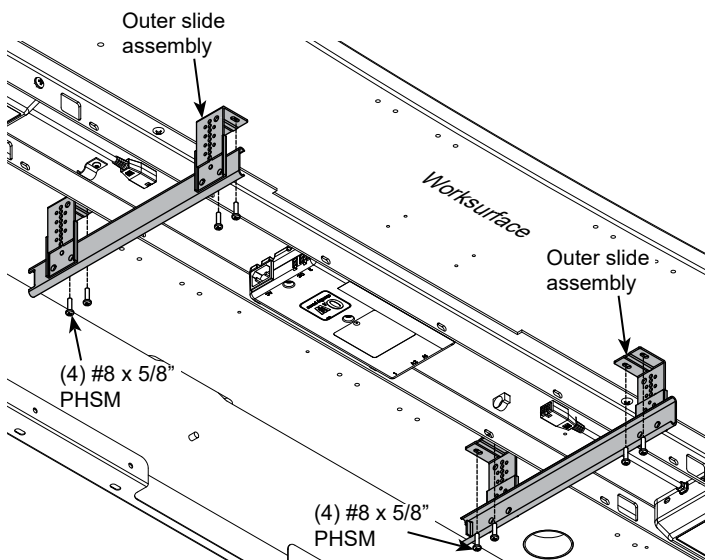

Figure 2.2

3. Install slide assemblies

Freedom XRS / Pivot Premiere:

1. Determine the preferred position of the keyboard tray (left center right). Pre-drilled mounting holes are available for multiple mounting locations.
2. Attach each outer slide assembly to the underside of the worksurface with (4) #8 x 5/8" PHSM screws but do not tighten completely. (Brackets face inward). **Figure 3.1.**
3. Tighten screws on one slide assembly only-leave the screws on the other slide assembly slightly loose.



Note: The lecterns have pre-drilled holes in left, center, and right positions for keyboard tray mounting.

On Freedom XRS Lecterns, the keyboard tray should be installed on the side opposite the equipment rack (if equipped).

Figure 3.1

CORE Lectern:

1. Align and attach the left and right slide assemblies with 8-32 x 1/2" PH thread-cutting screws, but do not tighten completely. **Figure 3.2.**

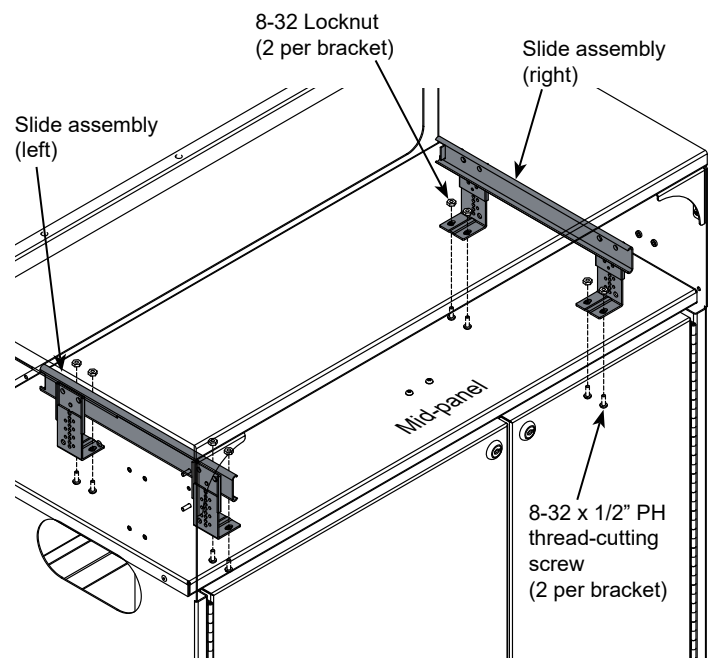

Figure 3.2

4. Install keyboard tray

1. Align the keyboard tray assembly with the installed slides and slide together. **Figure 4.1-2.**
2. Open and close (cycle) the tray a few times to ensure parallel and free movement.
3. With the keyboard tray pulled out, securely tighten the (4) loose worksurface slide screws from step 3.

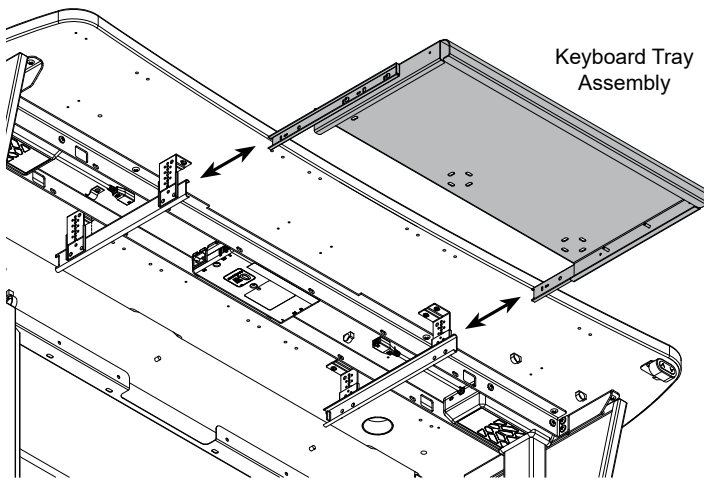

Figure 4.1

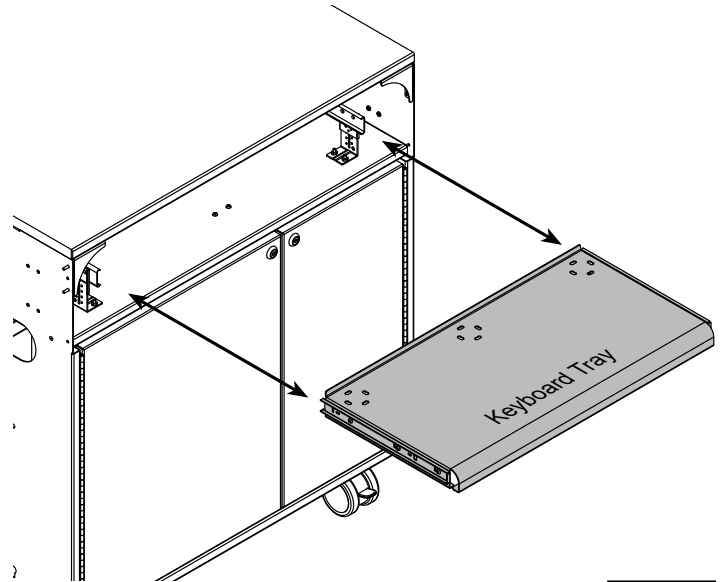

Figure 4.2

Flipping keyboard tray / drawer - optional

Note: The dual-use tray can be used as a keyboard tray, or easily flipped and used as a drawer.

1. To flip, pull the tray out fully and locate the plastic lever on each slide. **Figure 5.**
2. Release the levers on the both slides while pulling the tray out.
3. Flip the tray over, re-align the slides, and push tray back in.

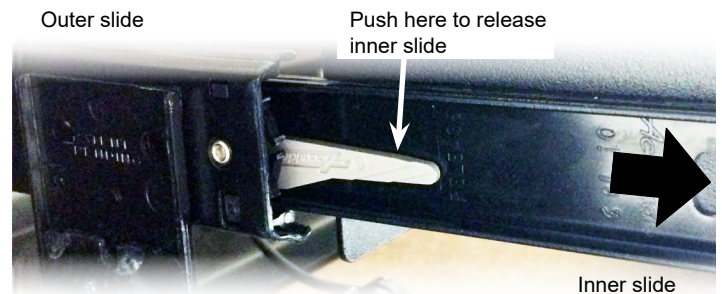

Figure 5