

Assembly Instructions

⚠ Important ⚠

Before you begin, read and comply with all safety and operating instructions, and ensure all parts and correct quantities are included.

Any parts damaged during shipment must be reported within 5 days of receipt. To report information regarding missing parts or damage, to purchase parts or accessories, or if you have any questions, please contact us.

www.spectrumfurniture.com
800-235-1262, 715-723-6750

Thank you for purchasing Spectrum products!



(1) 0145714
Logo panel

(1) 0147587
Logo backer



(4) 033919
6-32 Keps nut



(4) 0100166
6-32 x 1/2" PH thread-cutting screw

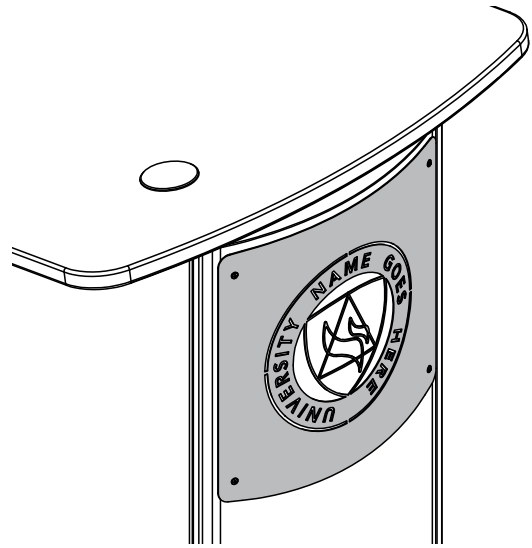

Customized Logo Panel for Slim Lectern 55513

Tools Required



1. Mark hole locations on lectern

- Using a pencil and measuring tape, measure out and mark a centered vertical line on the audience-side panel. **Figure 1.** Use two points (one on top, one on bottom) to establish the line-this will provide the most accuracy.
- Using the template on p.3, measure and mark 1.44" down from the top of the panel to mark a level horizontal line on the audience-side panel.
- Using the template, measure 9.567" down from the first line to mark a second horizontal line on the audience-side panel.
- Place the logo panel up against the curved panel and mark the 4 hole locations.

2. Drill hole locations

- Place masking tape on the laminate at the (4) hole locations.
- Carefully drill through the audience-side panel at the (4) hole locations using a 5/32" drill bit. **Figure 1.**

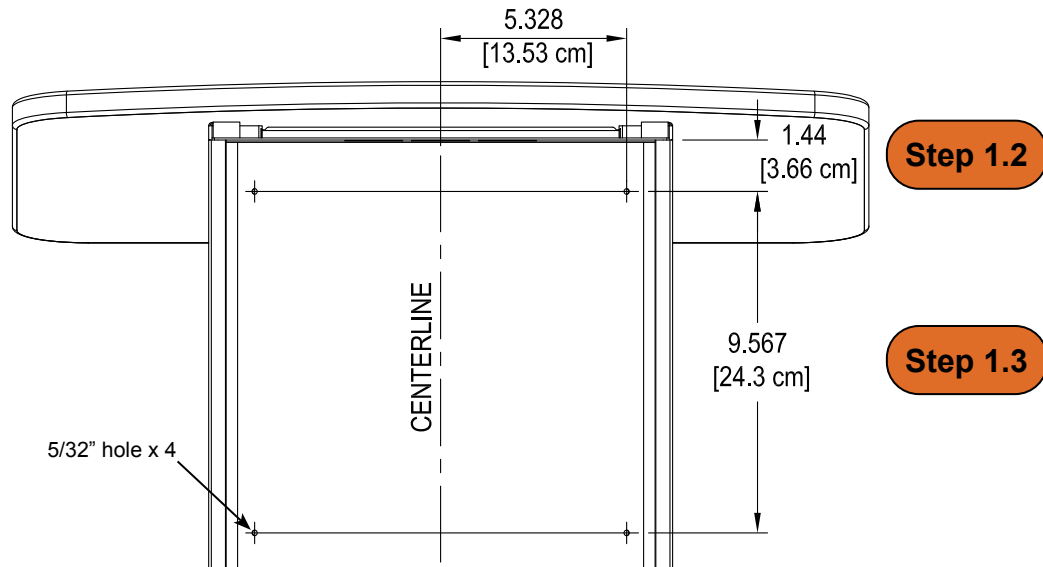

Figure 1

2. Install logo panel

1. If you have a laminate backer, place it under the logo panel.
2. Secure the logo panel to the lectern with (4) 6-32 x 1/2" PH thread-cutting screws and (4) 6-32 keps nuts on back. **Figure 2.**
3. Tighten all screws securely.

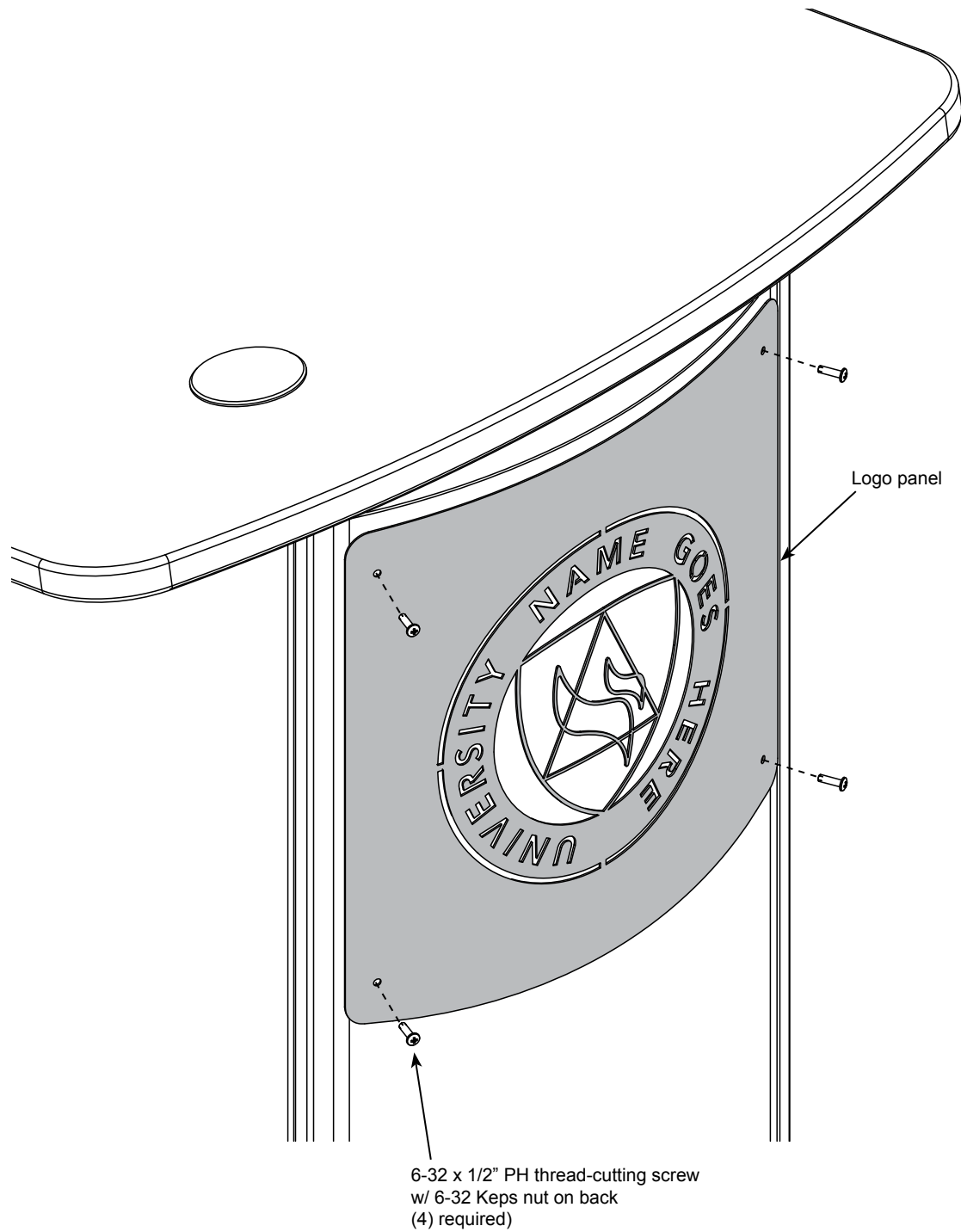

Figure 2

55513 Logo panel template (scale 1:1)

Step 1.2

1.44
[3.66 cm]

9.567
[24.3 cm]

Step 1.3