

Assembly Instructions

To purchase parts or accessories, please contact us at
www.spectrumfurniture.com
1-800-235-1262
 Thank you for purchasing Spectrum products!

Before you begin, please make sure all parts and proper quantities are included. Any parts damaged during shipment must be reported within 15 days of receipt. To report information regarding damages or if you have any questions, please call 1-800-235-1262.

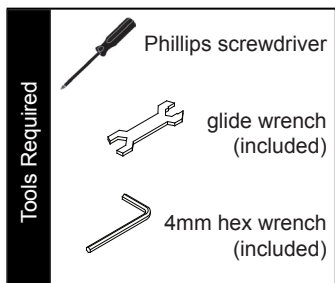
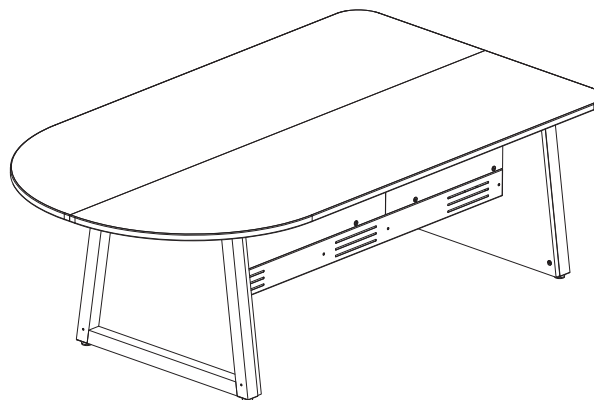

InVision™ Media Collaboration Table
 48" x 60" - #37102
 48" x 84" - #37103
 60" x 60" - #37104
 60" x 84" - #37105

Note: The worksurface halves must be assembled prior to the table assembly shown here. Refer to the assembly instructions included with the worksurface halves (Box #1) for assembly procedure.



Leg Assemblies (Box #2)

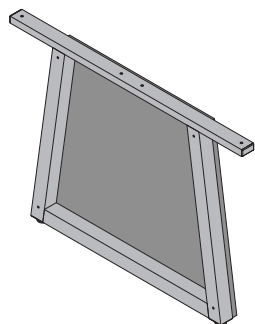

(1) 0112522
front leg assembly

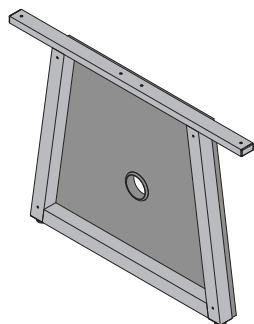

(1) 0112535
rear leg assembly
(with grommet hole)

- (26) 035728
1/4-20 x 1/2" PHMS
- (4) 037779
5/16-18 x 1" glide
- (8) 0100167
8-32 x 1/2" PH
thread-cutting screw
- (2) 0104836
4" snap-in grommet
- (16) 059534
1/4-20 x 30mm JC bolt
- (1) 021263
3-1/4" round grommet
- (8) 041289
1/4-20 x 1-3/4" PHMS
- (1) 025069
glide wrench
- (2) 059899
1/4-20 x 45mm JC bolt
- (1) 025039
4mm hex wrench
- (2) 021555
1/4-20 JC nut

Cord Channel (Box #3)

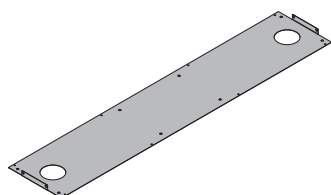

(1) bottom panel
0112496 - 84" tables
0112541 - 60" tables

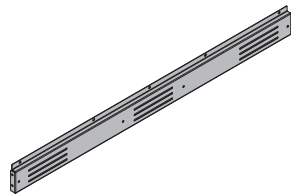

(4) cord channel rail
0112495 - 84" tables
0112540 - 60" tables

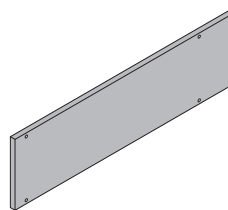

(2) long side panel
0112491 - 84" tables
0112542 - 60" tables

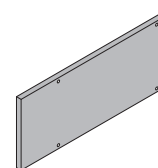

(2) 0112492
short side panel

1. Attach legs to worksurface

- A. Set the assembled worksurface face-down onto a flat non-abrasive surface like a carpeted floor close to the table's final location.
- B. Set the legs onto the bottom of the worksurface as shown with the insert panels facing toward the center. **Figure 1**. Note the rear leg (with the grommet hole) will mount on the flat edge of the worksurface.
- C. Align the mounting holes and attach the legs with 1/4-20 x 1-3/4" PHM screws. Do not tighten these screws completely yet.
- D. On the rear leg, install (2) 1/4-20 JC nuts, and (2) 1/4-20 x 45mm JC bolts through the worksurface. (This will require the worksurface be lifted slightly off the floor and blocked up temporarily to install). It's important these fasteners be installed for support before the unit is tipped upright.
- E. Install the glides onto the bottom of the legs and tighten securely.

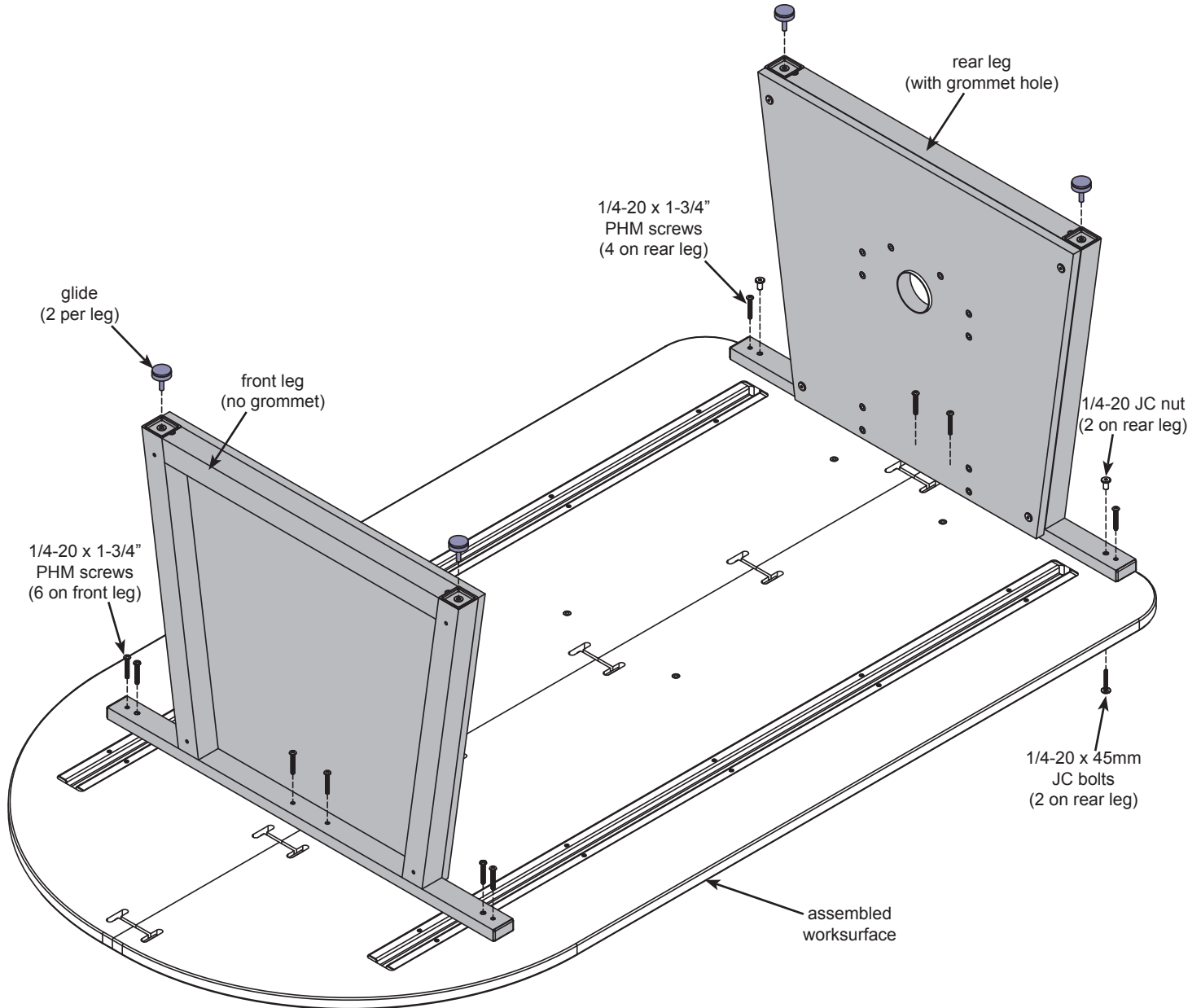

Figure 1

2. Attach cord channel rails to legs

- A. Orient the upper cord channel rails with the inside rail flanges pointing up from the worksurface as shown. **Figure 2A.** Attach to the worksurface with 1/4-20 x 1/2" PHM screws.
- B. Orient the lower cord channel rails with the inside rail flanges pointing toward the upper rail flanges as shown and attach the end of each rail to each leg with (2) 1/4-20 x 1/2" PHM screws. **Figure 2B.**

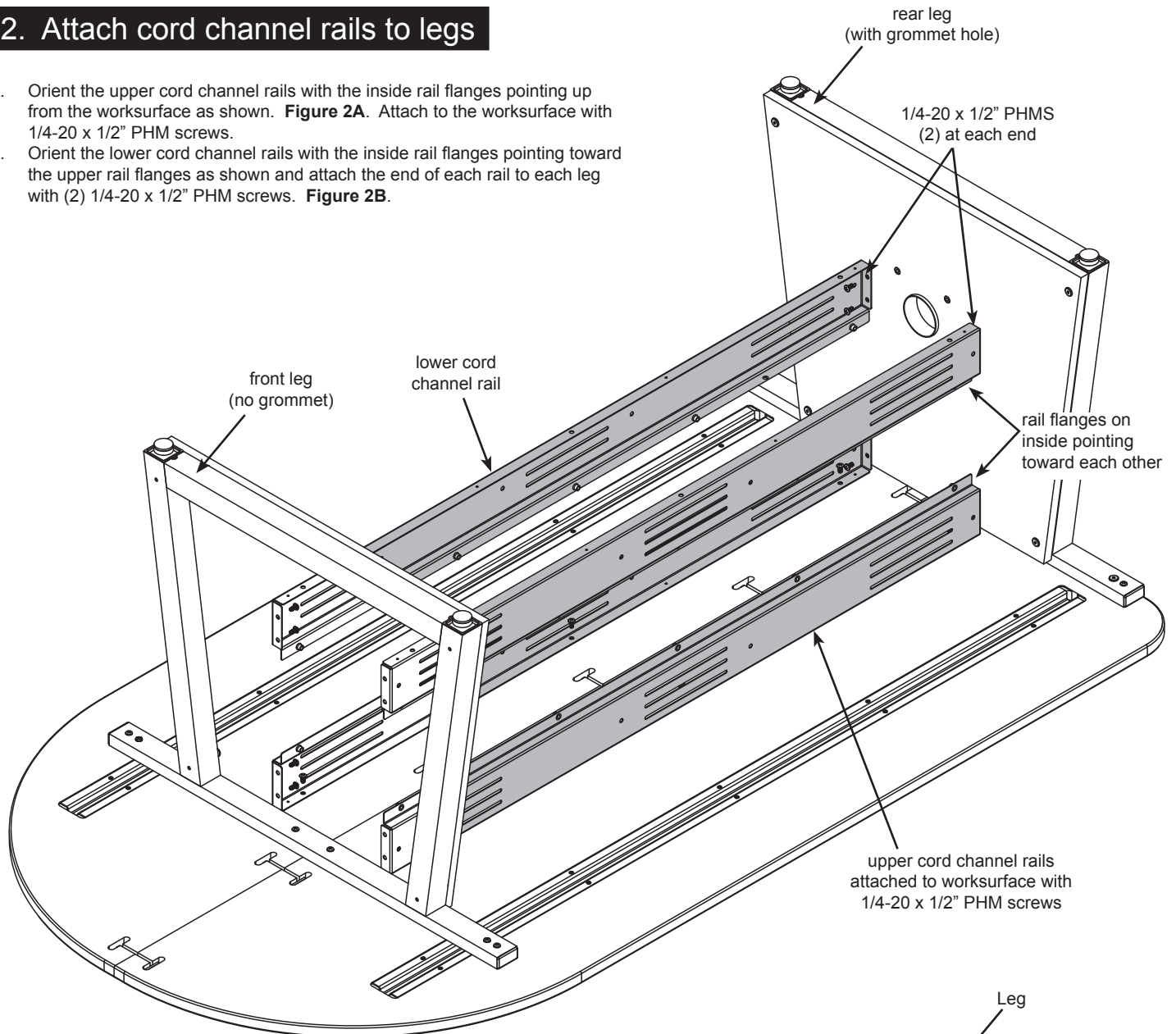

Figure 2A

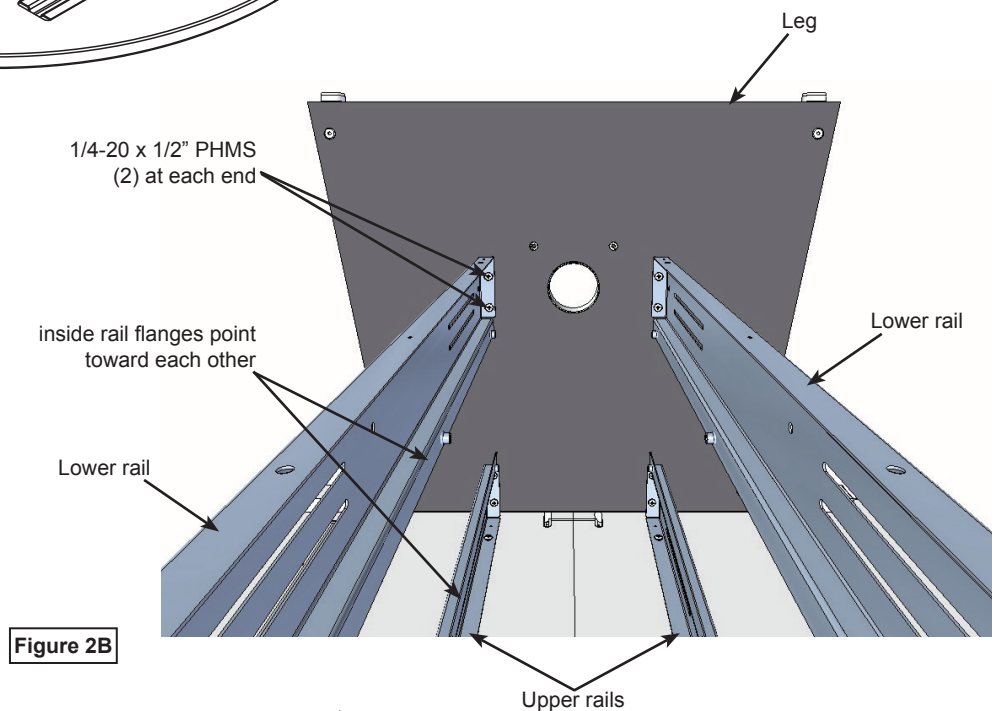

Figure 2B

3. Attach bottom panel

- A. Attach the bottom panel to the two lower rails with (8) 8-32 x 1/2" PH thread-cutting screws as shown. **Figure 3.**
Note the end tabs will be pointing upward.
- B. Attach each end tab on the bottom panel to each leg with (2) 1/4-20 x 1/2" PHM screws.
- C. Tighten the leg screws from step 1C securely.

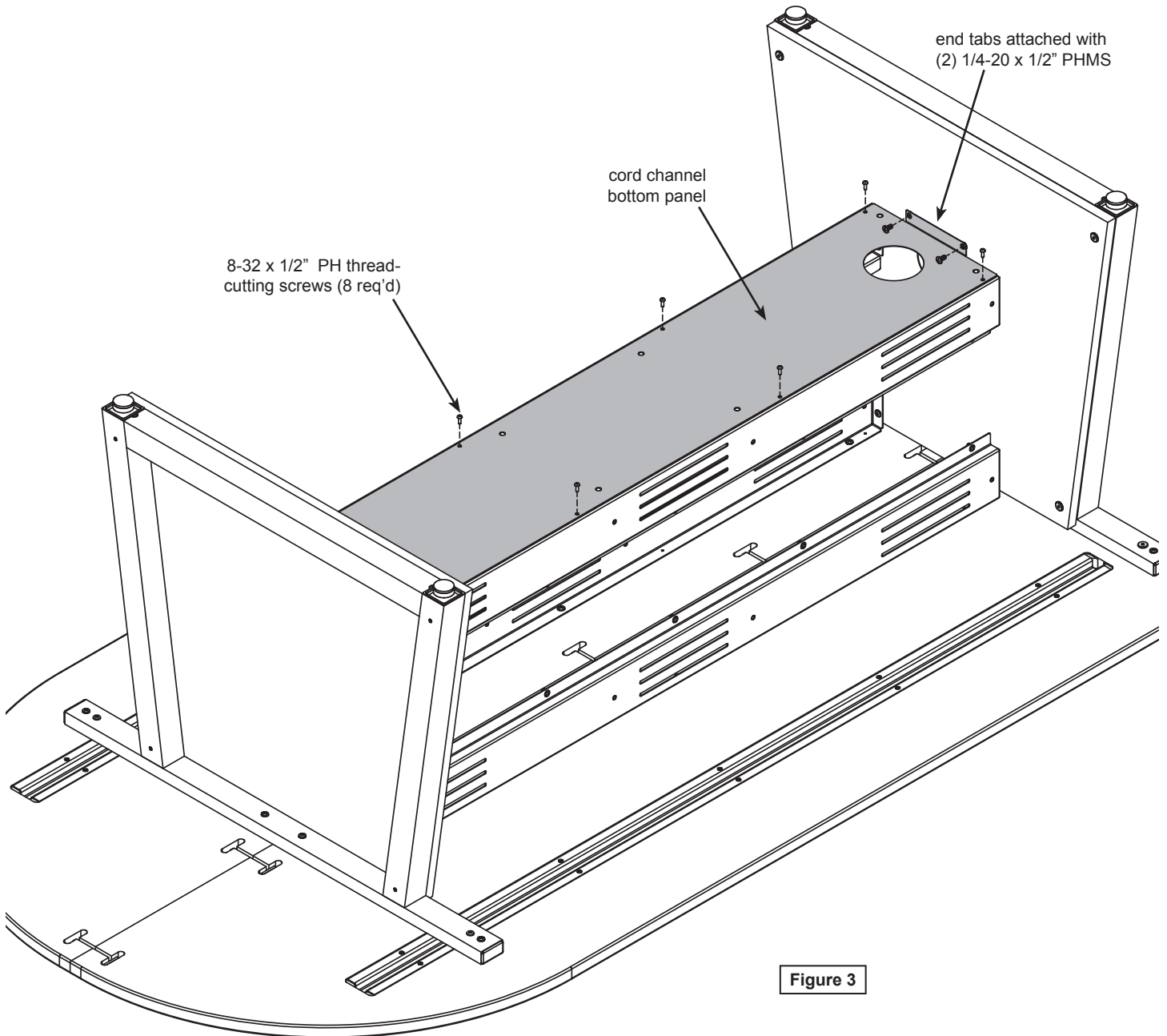

Figure 3

Optional - Attach equipment rack to cord channel

Note: The following procedure shows how to attach an optional equipment rack to the table while the table is still upside-down during the table assembly.

- A. Lower the equipment rack over the cord channel as shown. Note the hinge-side of each door will go toward the flat edge (or rear) of the table. **Figure 3A.**
- B. Open both equipment rack doors. **Figure 3B.**
- C. Align the equipment rack and upper cord channel rail mounting holes.
- D. Attach the equipment rack to each upper cord channel with (2) 1/4-20 x 1/2" flanged hex head screws and 1/4-20 keps nuts. **Figure 3B.**
- E. Install (2) 1/4-20 x 1/2" flanged hex head screws through the cord channel bottom panel into each equipment rack side panel. **Figure 3B.**

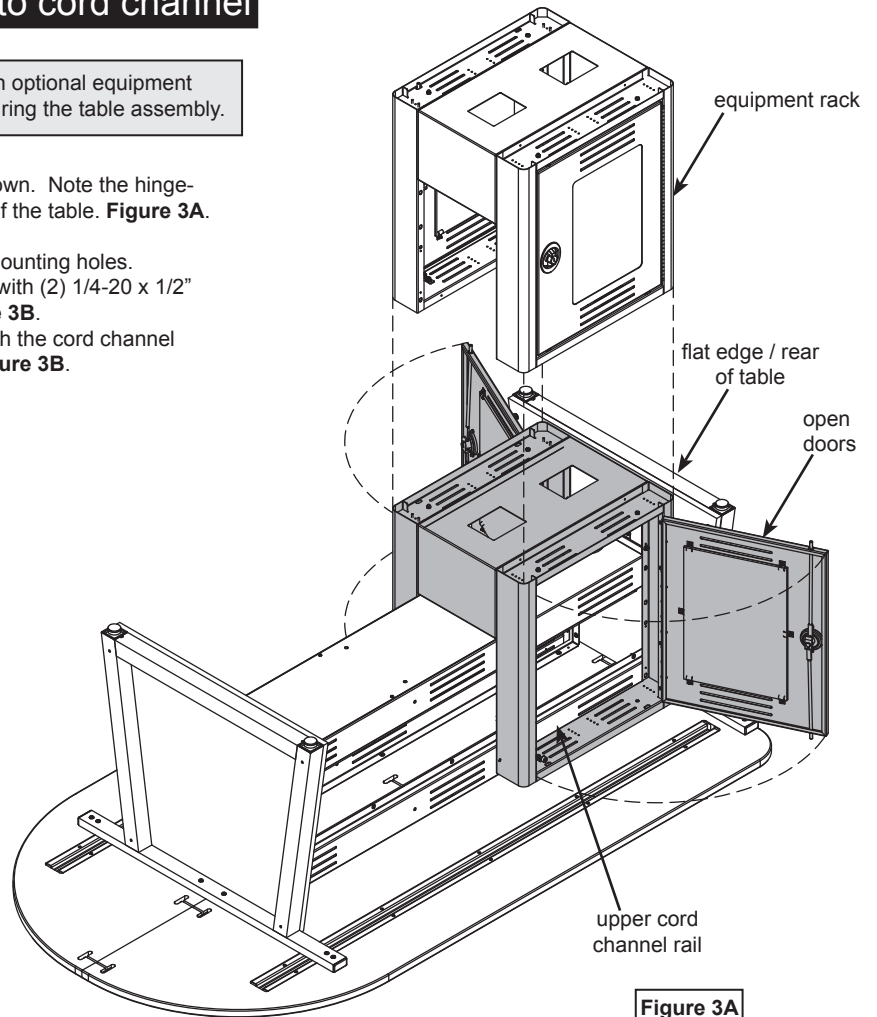

Figure 3A

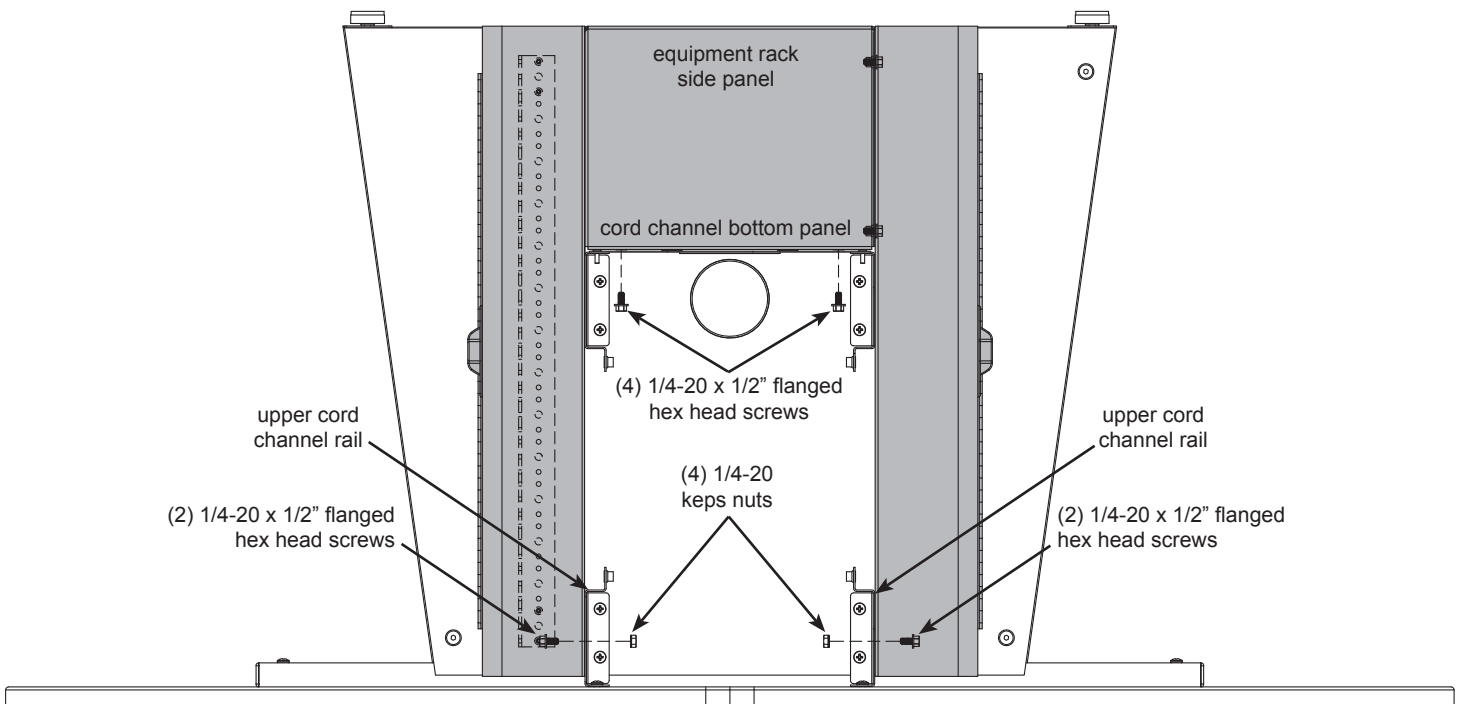

Figure 3B

4. Flip table upright

- A. Using 4-5 people, carefully tip the table up on its side and over until upright. **Figure 4.**

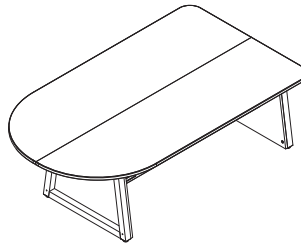

Figure 4



The table is heavy when assembled. Use caution when flipping upright.

5. Install grommets

- A. Install (2) 4" snap-in grommets into the bottom panel. **Figure 5.**
B. Install (1) 3-1/4" grommet into the rear leg panel.

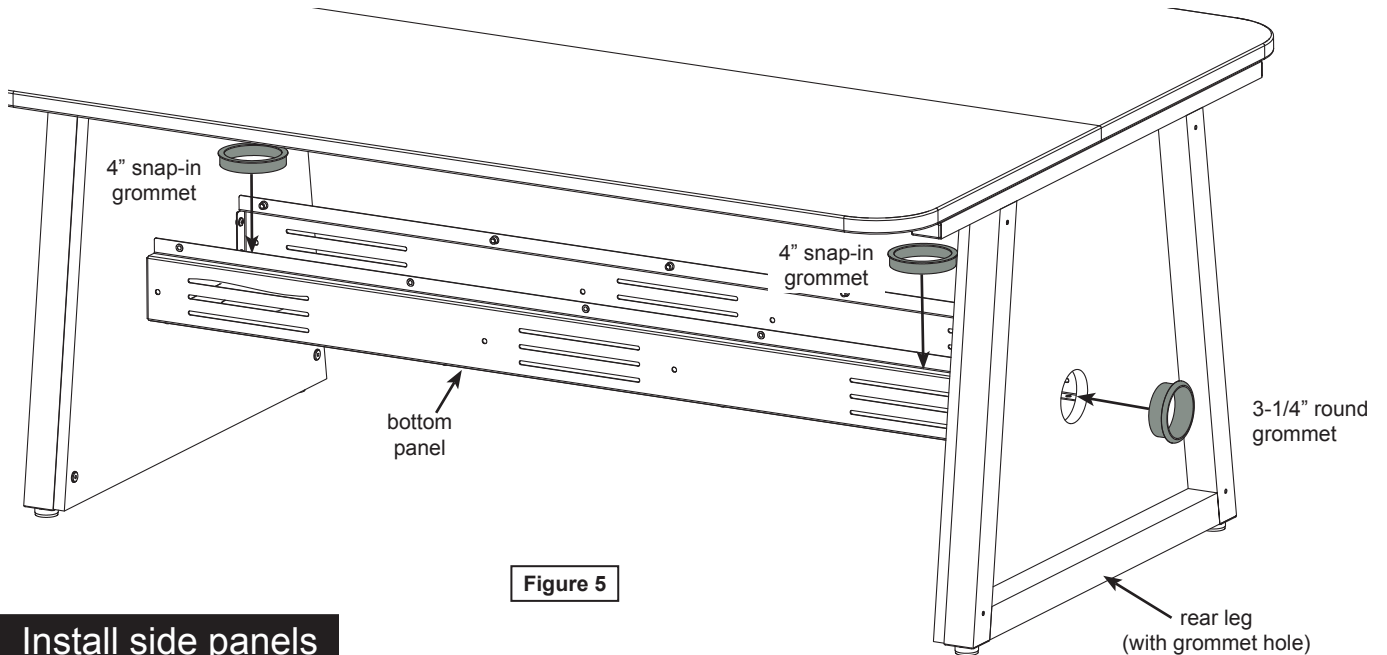

Figure 5

6. Install side panels

- A. Attach the short side panel to the cord channel rails toward the rear leg with (4) 1/4-20 x 30mm JC bolts. **Figure 6.**
B. Attach the long side panel to the cord channel rails toward the front leg with (4) 1/4-20 x 30mm JC bolts.
C. Repeat procedure on the other side of the table.

Note: If an equipment rack has been installed and will be permanent, the short side panels will not be needed.

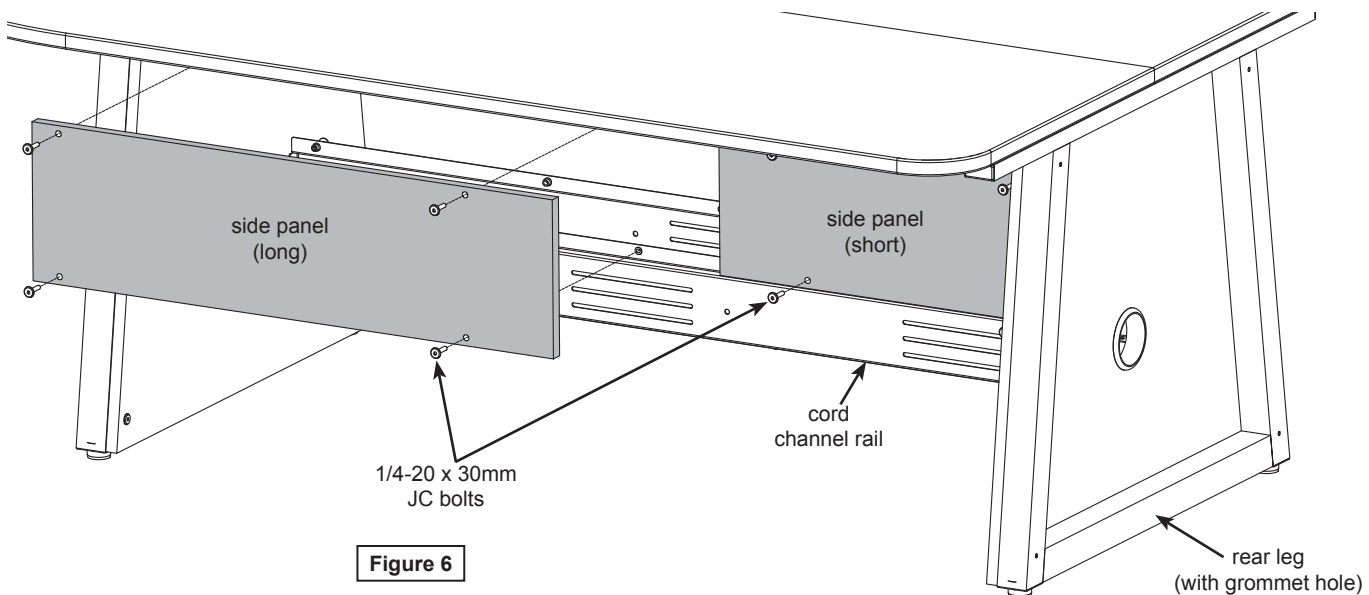

Figure 6

Worksurface cutouts

Note: Cutouts in the worksurface can be made by the customer after the table has been assembled, but are only recommended within the maximum cutout area shown in **Figures 7A & 7B**. Cutouts made beyond this shaded area could interfere with the legs, cord channel rails, or worksurface reinforcement bars.

Note: When locating cutouts in the worksurface, consideration should be given to avoid the draw bolts along the worksurface seam. See draw bolt location dimensions.

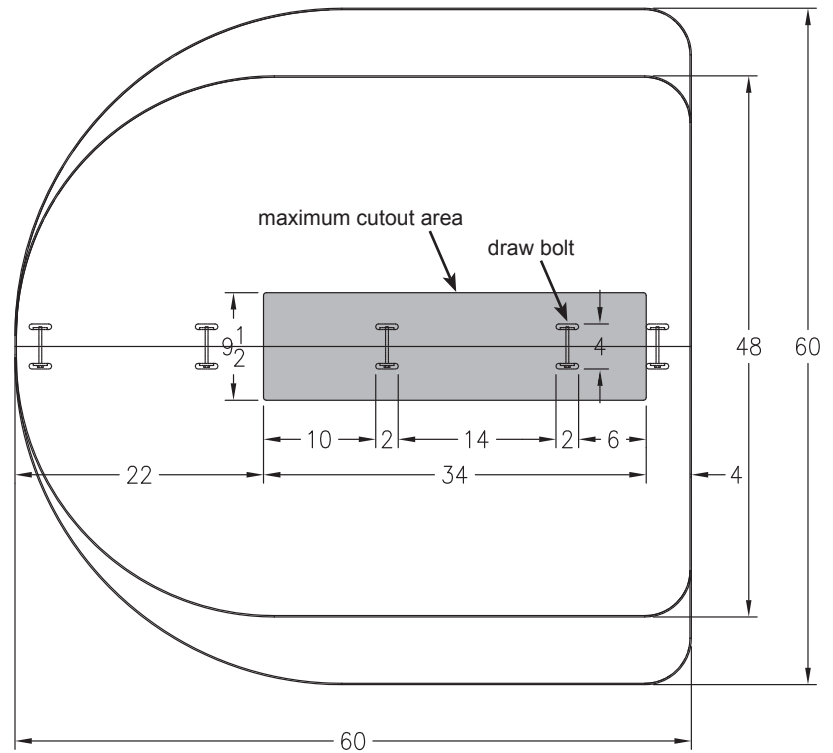

Figure 7A

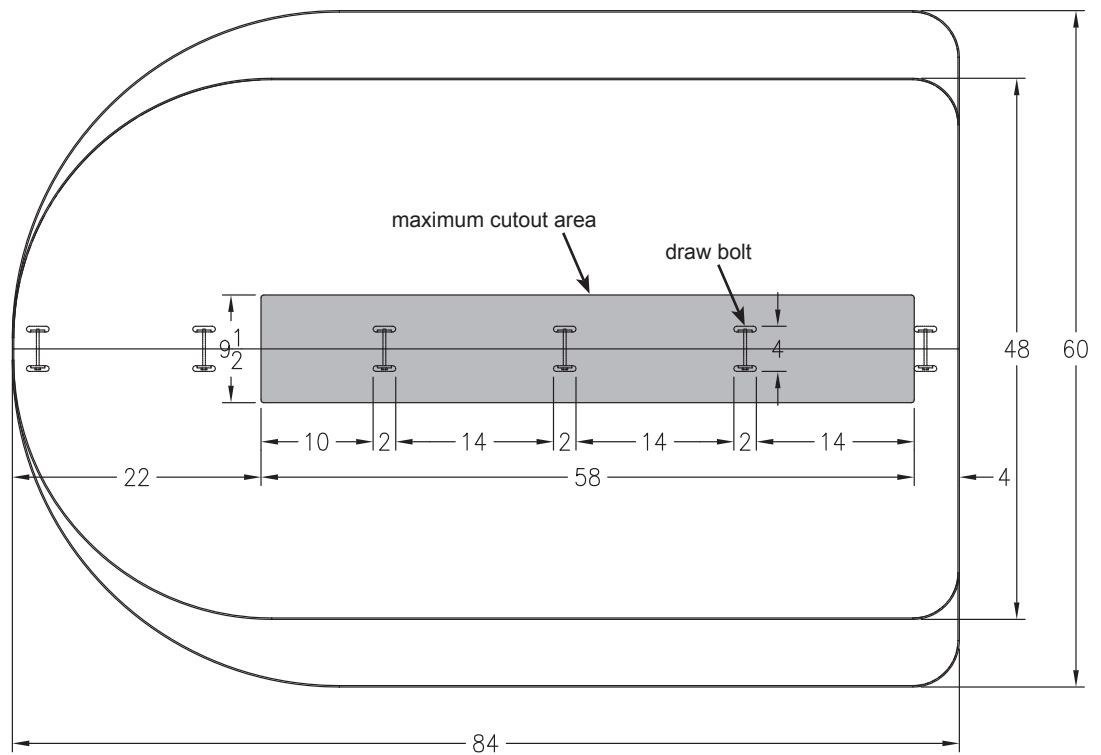
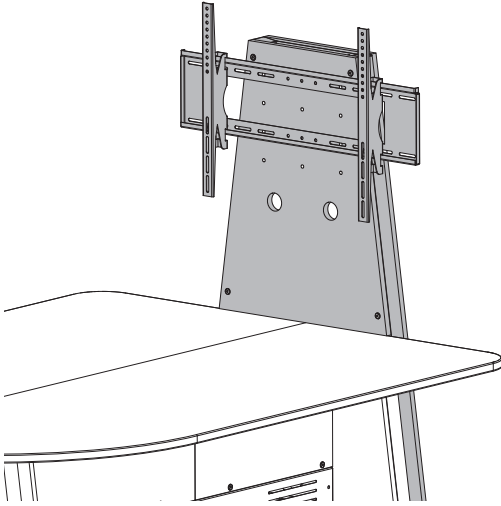
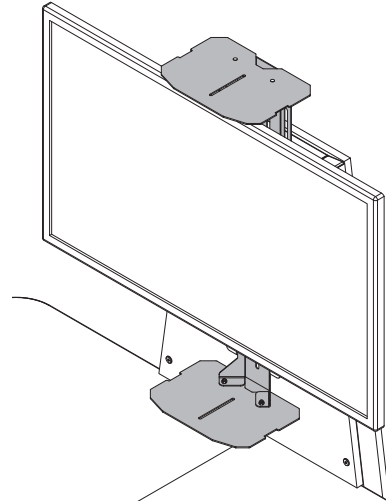

Figure 7B

Options



Display Stand w/ Monitor Mount
mount supports 37"-63"
monitors up to 200 lbs
37106



Camera Mount
attaches to display stand
above or below monitor
(1 mount included)
37108

⚠ WARNING ⚠
The monitor should always be lifted
off the stand before moving the table.

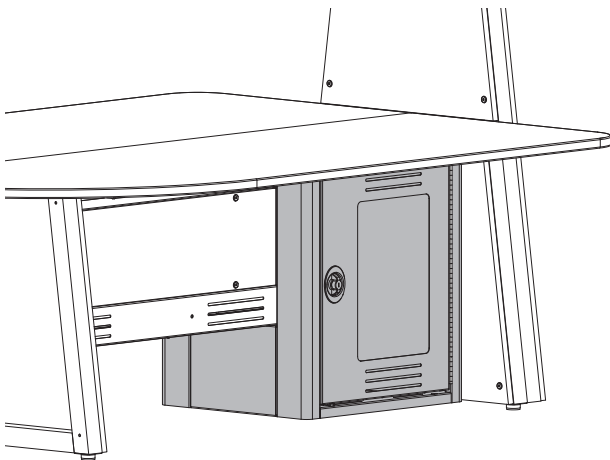

Equipment Rack
7RU w/ 10" depth
4½RU w/ 2½" depth
37107

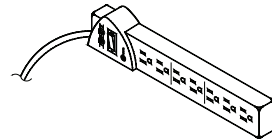

7-Outlet Power Strip, insured
w/ surge protector, bracket, and 12' cord
99024

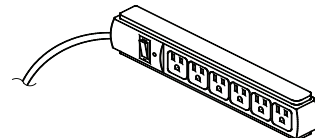

6-Outlet Power Strip
w/ 12' cord
99023

Warranty

WE WILL MAKE IT RIGHT FOR YOU!

Spectrum is committed to provide complete customer satisfaction. Each of our products are manufactured from the best materials available and each product is stringently monitored throughout the production process through our P.A.C.E. program (Product Assurance to meet Customer Expectations). Our Customer Service Help Line 1-800-235-1262 is ready to provide immediate attention to any questions, comments or concerns. We are available to answer your calls Monday through Friday from 7 am to 5 pm CST, excluding observed holidays. In addition your product comments or concerns are welcome via e-mail at: spectrum@spectrumfurniture.com.

Warranty Statement

We guarantee all Spectrum products to be free of all defects in materials and workmanship, for the original owner, for a period of ten years. Any item deemed defective by Spectrum or the original manufacturer, under normal use conditions, will be repaired or replaced at Spectrum's discretion. This warranty applies to all products manufactured and distributed by Spectrum except the products listed below.

Items that have a varying warranty include, but are not limited to, the following:

- Adjustable Crank/Electric Desk Legs (1 yr)
- Flat Panel Desk Gas Cylinders (1 yr)
- Upholstered Soft-Goods (5 yrs)
- Adjustable Height & Stacking Chair Parts – including frames, gas cylinders, wood and plastic parts, and control handles (7 yrs)
- Adjustable Height & Stacking Chair Casters (2 yrs)
- Chair Upholstery & Textiles (2 yrs of normal use of Soft Goods, Adjustable Height, Stacking, Wood and Metal Chairs)
- Chair Upholstery - Graded-In Fabrics and C.O.M (no warranty)
- Height Adjustable Columns and Lifts (1 yr)
- General Use Casters (1 yr)
- Electrical – Electri-Pak, Power Communication Modules, and special order ECA electrical items (1 yr)
- Electrical - Power Strips & Electrical Timers (1 yr)
- Electrical Surge Suppressors (lifetime)
- Electrical - Retractable Power Cords (1 yr)
- Keyboard/Mouse Trays (1 yr)
- Flat Panel Monitor Arm – General Parts (5 yrs)
- Flat Panel Monitor Arm – Gas Cylinders (2 yrs)
- CRT Monitor Arm (1 yr)

Warranty is void if product is not used for its intended purpose or subjected to an unusual application, multiple-shift use, alteration, accident, abuse or abnormal wear and tear. Representations of colors on-line and in printed materials are meant to be a close reference to the actual colors but not an exact match. Slight variations in color and texture of wood stains, powder coating, laminates, fabrics and other materials are normal in different manufacturing lots; as such these variations are not considered defects.

DESIGNED FOR INDOOR USE ONLY – Unless specifically stated in the product specifications, Spectrum's products have been designed and constructed for indoor use only. Moving or using outdoors, or on excessively rough surfaces, may cause damage to the products and will void the warranty. If an outdoor application is desired please contact us to discuss potential custom design solutions.

The warranty, as stated above, supersedes any previous warranties and is effective as of 9/1/2010

