

Console Gaming Hub™

37390

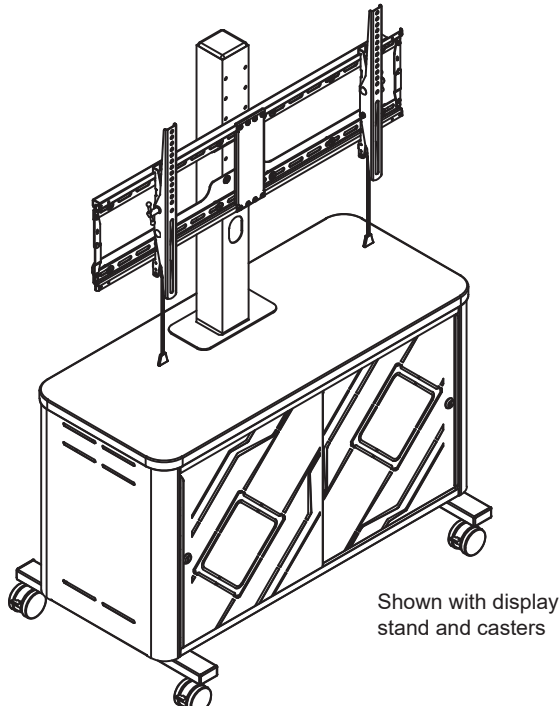

Shown with display stand and casters

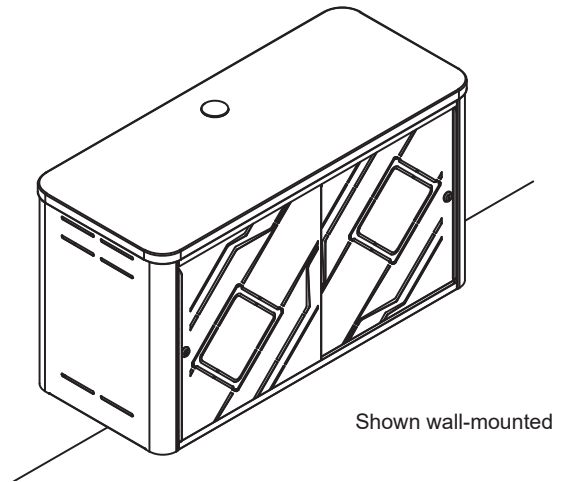

Shown wall-mounted

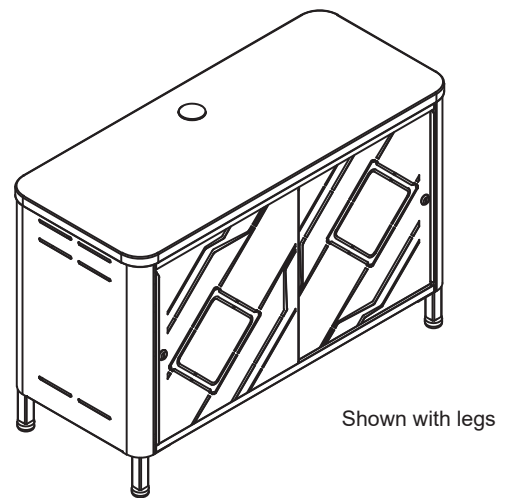

Shown with legs

<p>⚠ Important ⚠</p> <p>Before using this product:</p> <ul style="list-style-type: none"> • Read this manual • Comply with all safety and operating instructions • Ensure all parts and correct quantities are included <p>Any parts damaged during shipment must be reported within 5 days of receipt. To report information regarding missing parts or damage, to purchase parts or accessories, or if you have any questions, please contact us.</p> <p>Thank you for purchasing Spectrum products!</p>	<p>⚠ Important ⚠</p> <p>Avant d'utiliser ce produit:</p> <ul style="list-style-type: none"> • Veuillez à lire ce guide • Respectez les consignes de sécurité et d'utilisation • Vérifiez que vous disposez de toutes les pièces nécessaires à l'installation <p>Les pièces endommagées pendant le transport doivent faire l'objet d'un rapport dans les 5 jours de leur réception. Veuillez prendre contact avec nous si des pièces manquent ou sont abîmées, si vous avez des questions, ou encore pour acheter des pièces ou des accessoires.</p> <p>Merci pour votre achat d'un produit Spectrum!</p>	<p>⚠ Importante ⚠</p> <p>Antes de utilizar este producto:</p> <ul style="list-style-type: none"> • Lea este manual • Cumpla con todas las instrucciones de prevención de accidentes y operativas • Revise que todas las partes y las cantidades correctas estén incluidas <p>Si alguna parte se dañó durante el embarque, deberá reportarla en un lapso de 5 días a partir de la recepción. Para reportar cualquier información sobre partes faltantes o dañadas, para adquirirlas o comprar accesorios, o bien, si tiene alguna duda, póngase en contacto con nosotros.</p> <p>¡Gracias por adquirir productos Spectrum!</p>
--	--	---



<http://www.spectrumfurniture.com>

<p>Owner's Manual Le manuel du propriétaire El manual del propietario</p>	<p>Specs Spécifications Especificaciones</p>	<p>Video Vidéo Vídeo</p>
---	--	----------------------------------



800-235-1262

Components

(One) worksurface is included

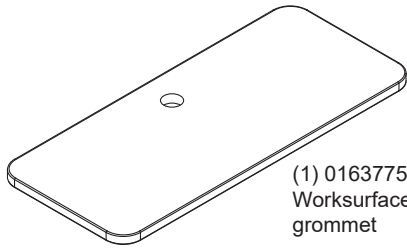

(1) 0163775
Worksurface w/
grommet

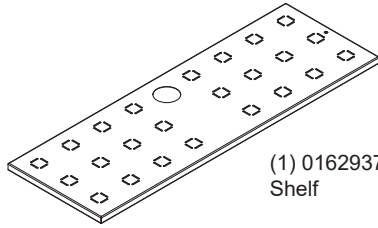

(1) 0162937
Shelf

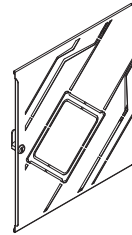

(2) 0162933
Door

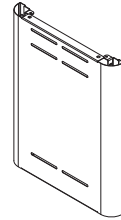

(2) 0163316
Side panel

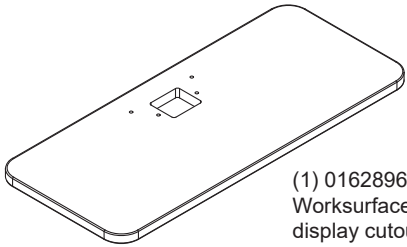

(1) 0162896
Worksurface w/
display cutout

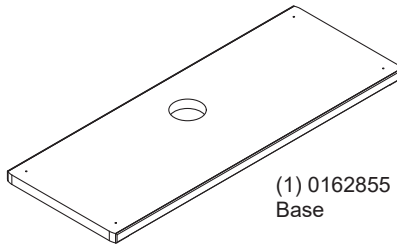

(1) 0162855
Base

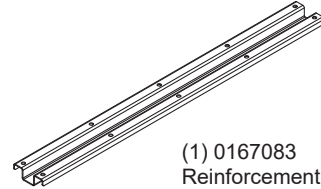

(1) 0167083
Reinforcement bar

Parts Bag



(4) 059533
10-24 x 1/2" PHSM

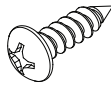

(39) 0101382
#14 x 7/8"
PHSM



(10) 052608
3/4"W x 5" Hook
& Loop strap



(4) 026022
Shelf Support Clip

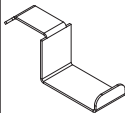

(4) 0163036
Headphone hook



(1) 039622
2" Grommet



(2) 059984
2" Snap-in grommet



(1) 021263
3-1/4" Grommet

Items from (one) of the below options will be included

Caster items

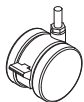

(4) 0105662
Caster

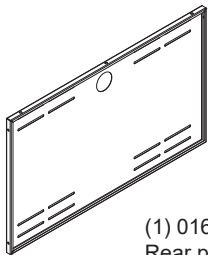

(1) 0162932
Rear panel (full)

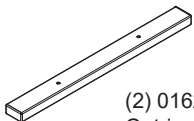

(2) 0162989
Outrigger

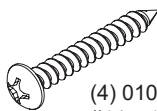

(4) 0101381
#14 x 1-3/4"
PHSM

Glide items



(4) 037779
Glide

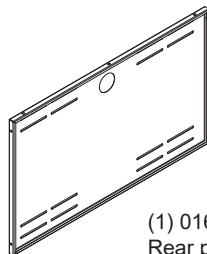

(1) 0162932
Rear panel (full)

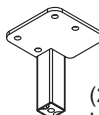

(2) 0162917
Leg for glides

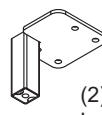

(2) 0163313
Leg for glides

Wall mounting items

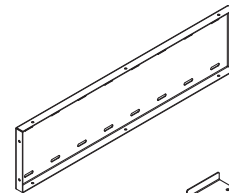

(1) 0162984
Rear panel (half)



(2) 0162987
Bracket

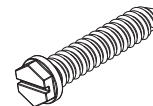

(4) 055699
1/4 x 1-1/4" Tapcon
Hex Slotted



(4) 026059
1/4" Flat Washer



Tools



Assembly tip: Do not tighten component fasteners completely until all have been installed. Keeping them loose will help with alignment between parts during assembly.

1 Attach side panels to base

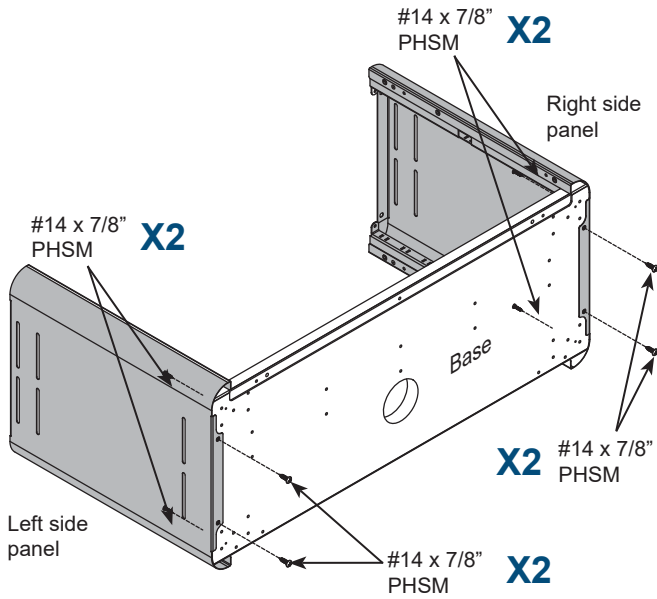

2 Attach lower channel to base

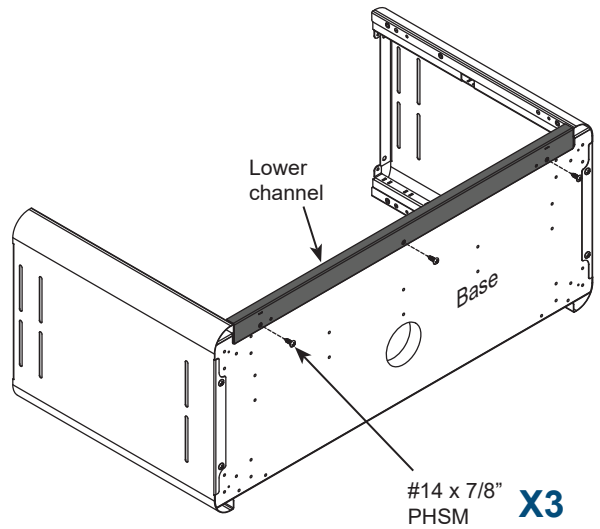

3 Attach back panel

Legs w/ Glides option

Caster option

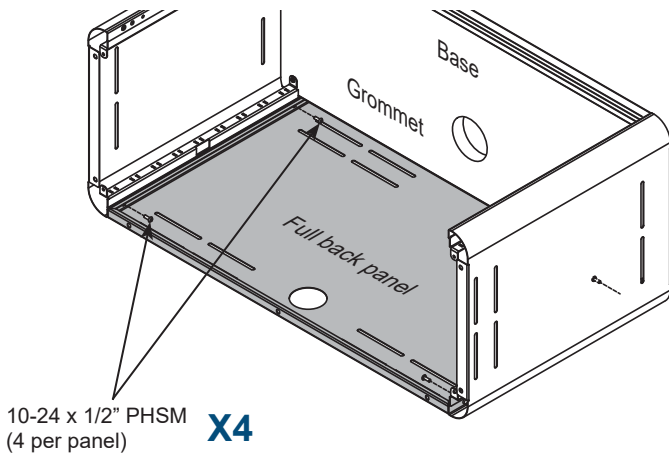

Wall mount option

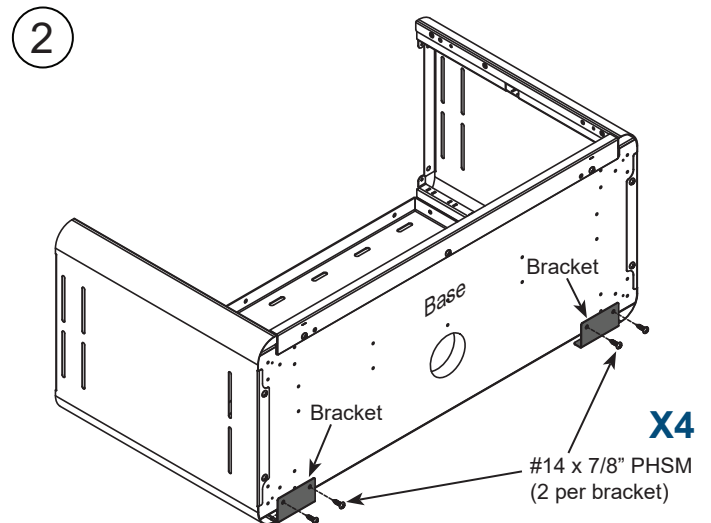
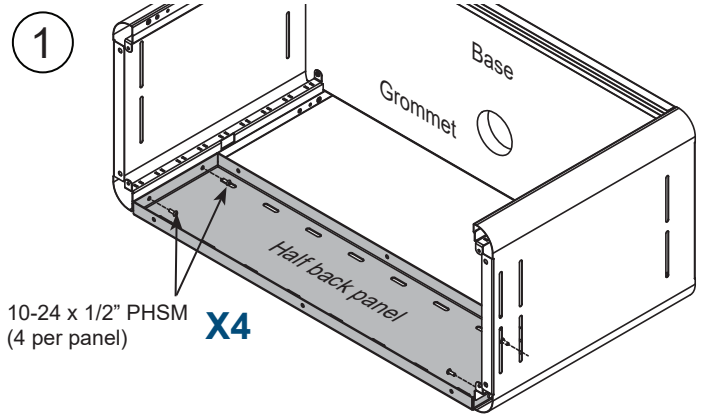

4 Attach worksurface

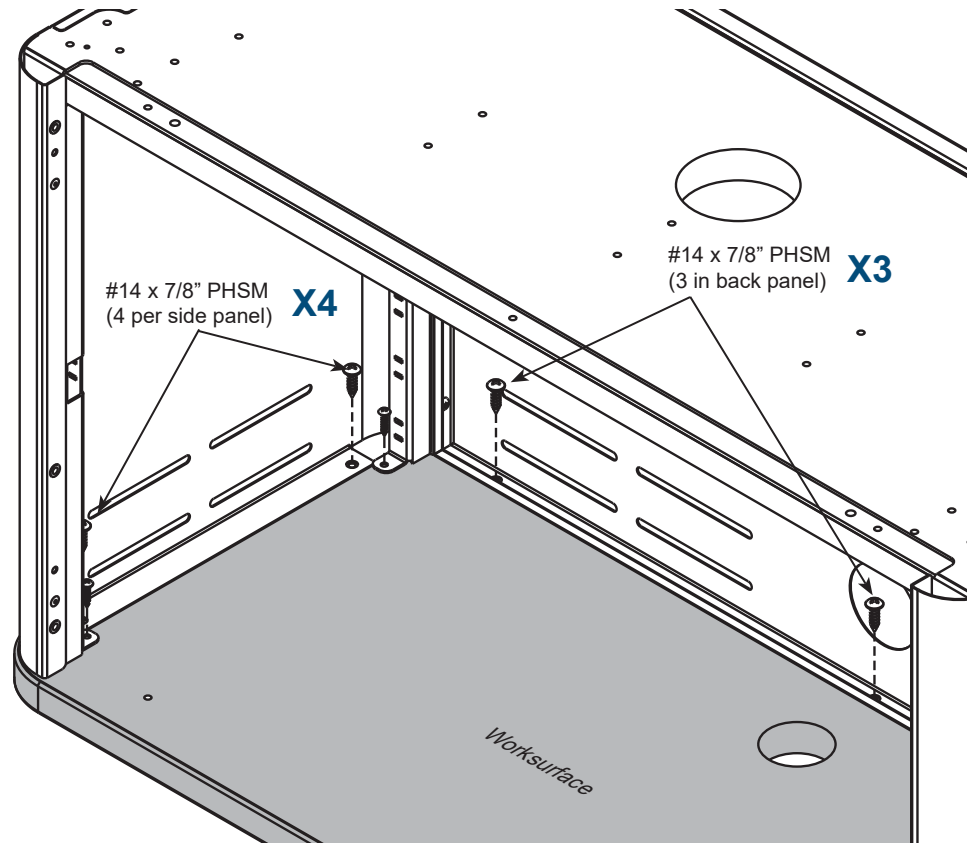

5 Flip unit upright

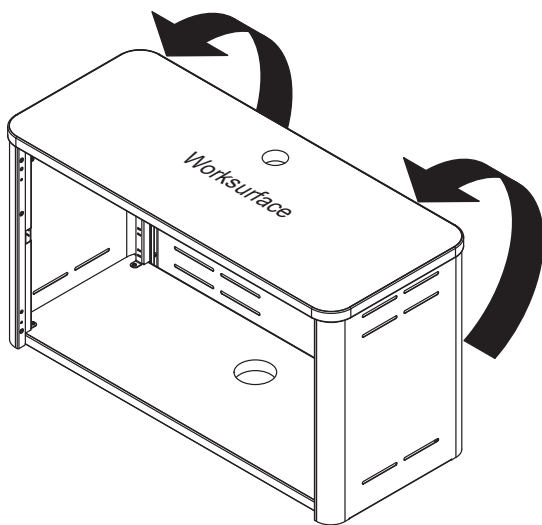

6 Set shelf inside

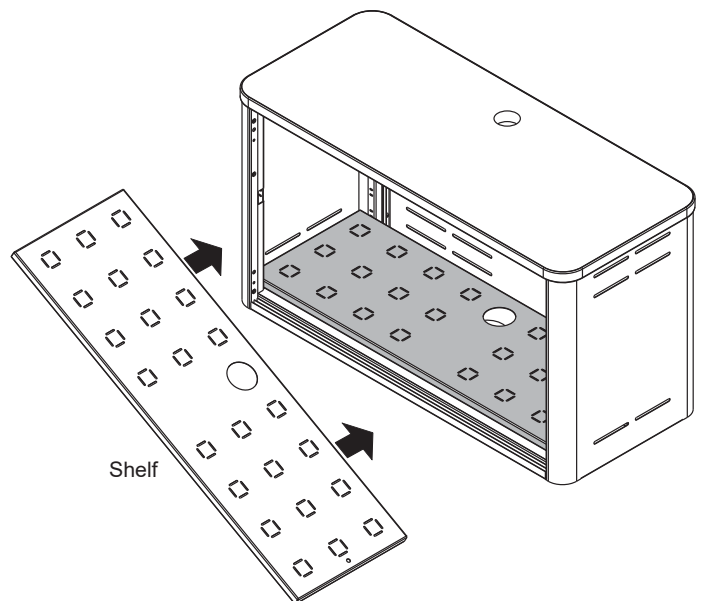

7 Install doors

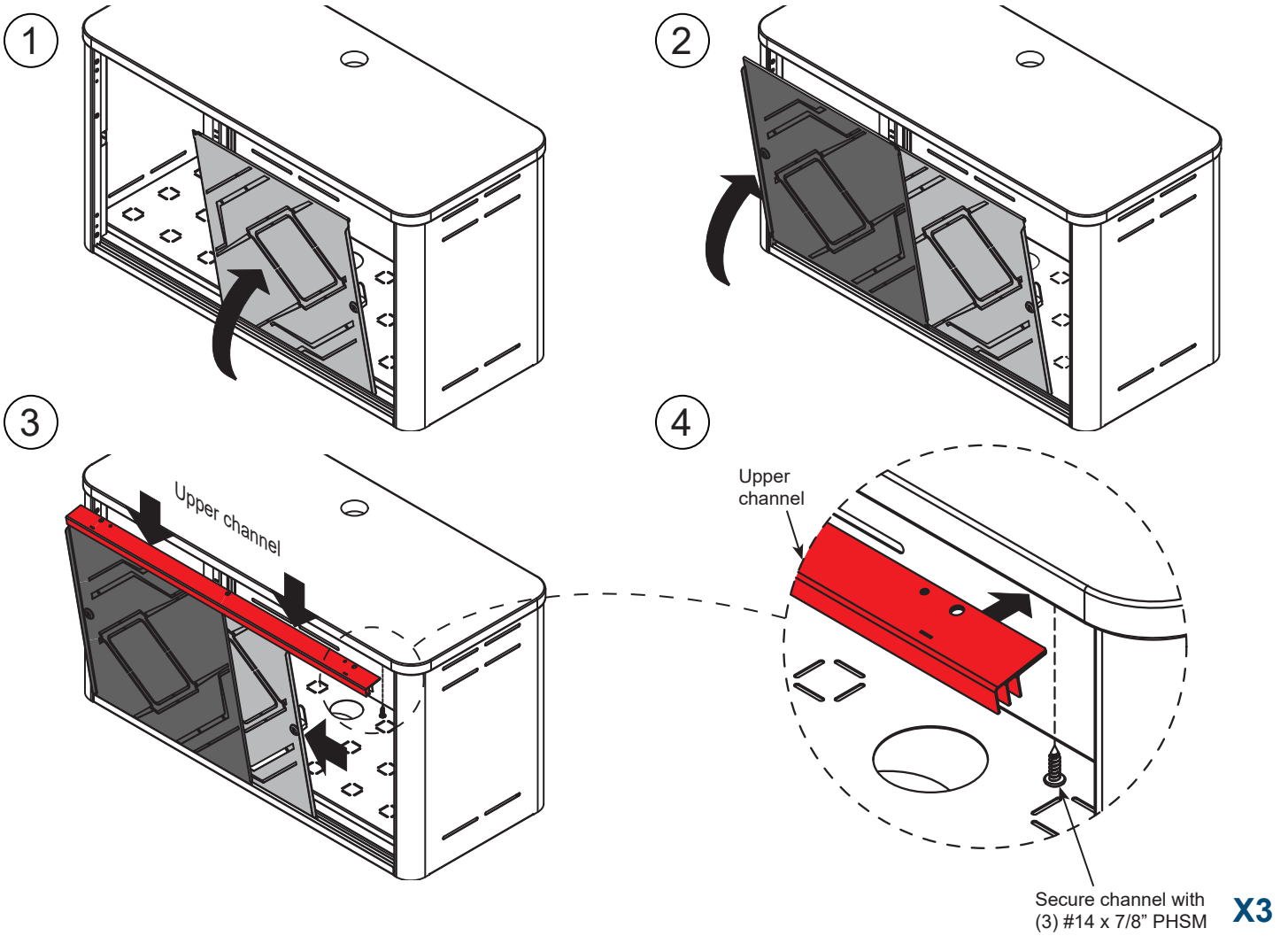

8 Install support brace

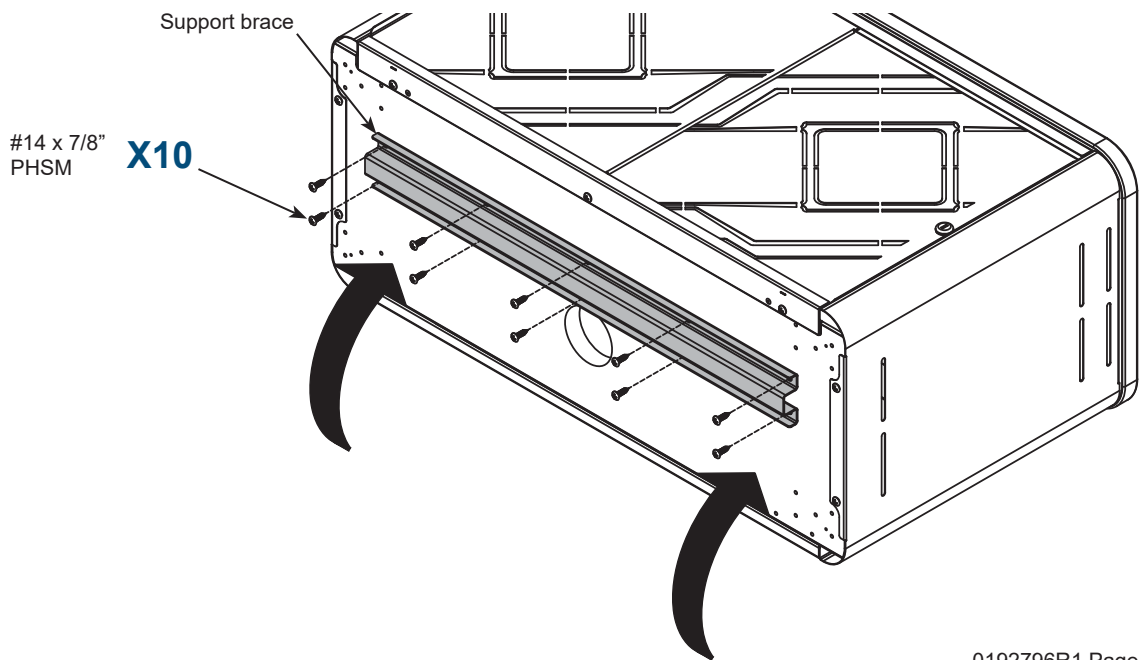

9 Install base option (skip to step 10 with wall-mount)

Legs w/ Glides option

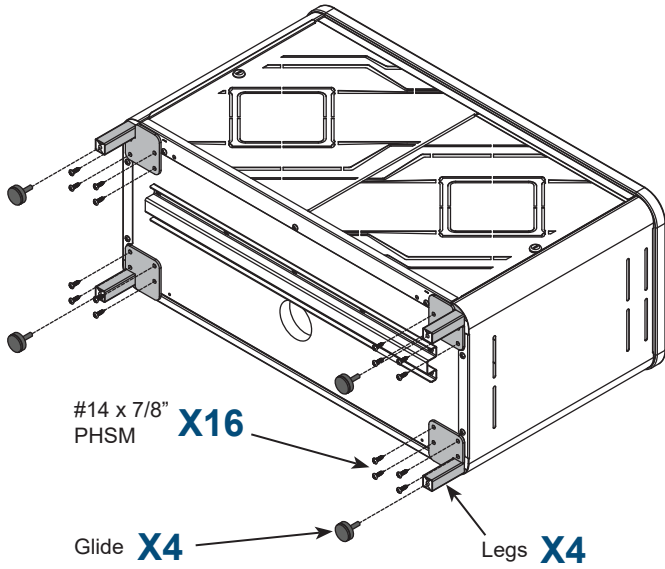

Caster option

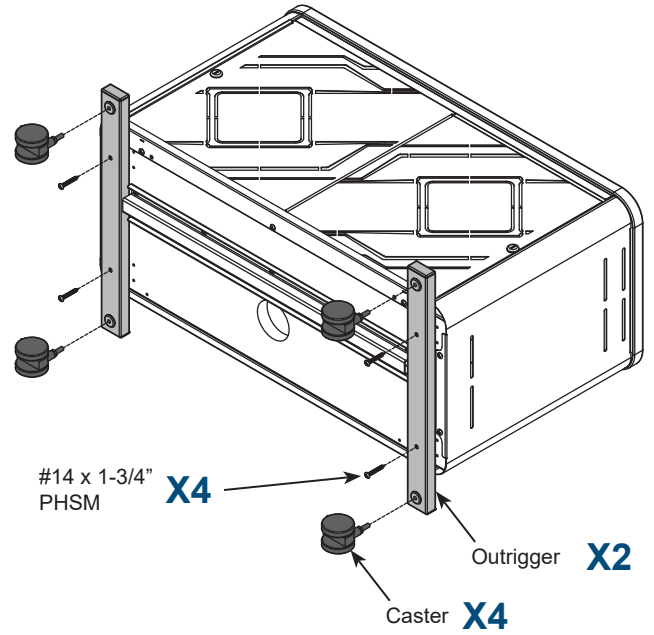

10 Flip unit upright

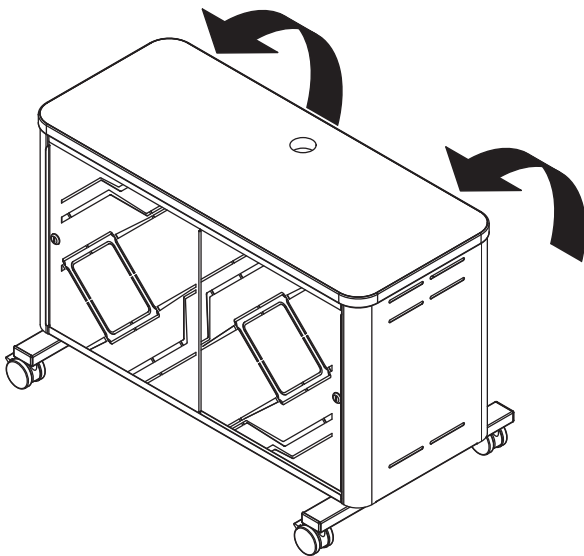

11 Install shelf brackets

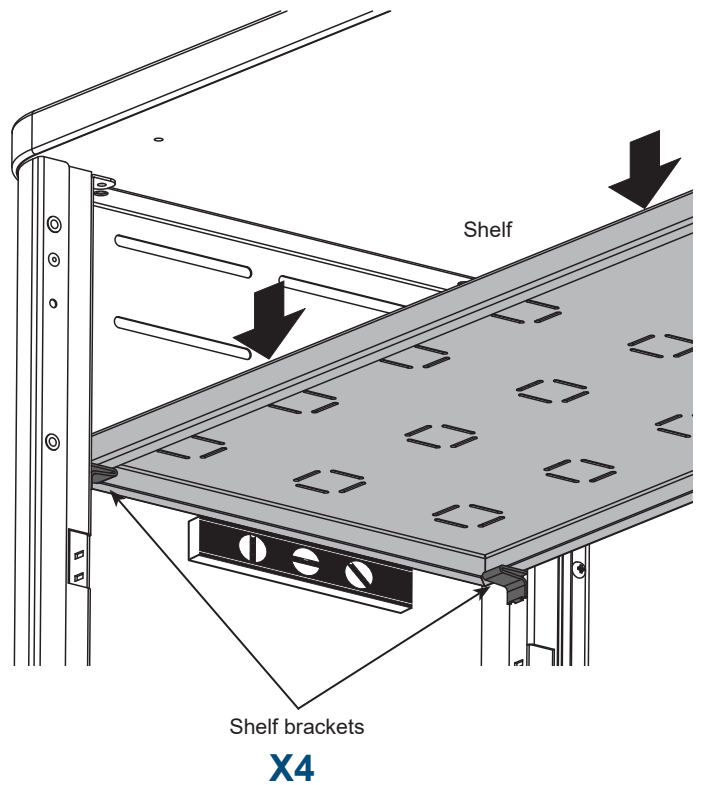

12 Install headphone hooks (optional)

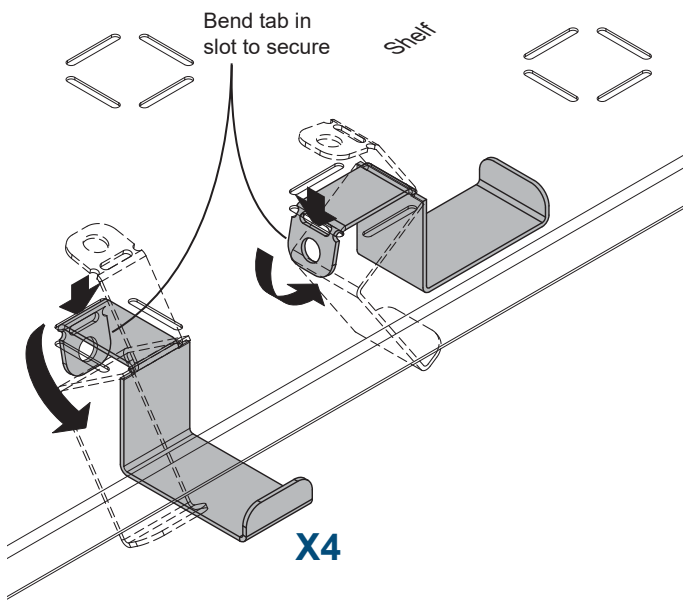

13 Install grommets

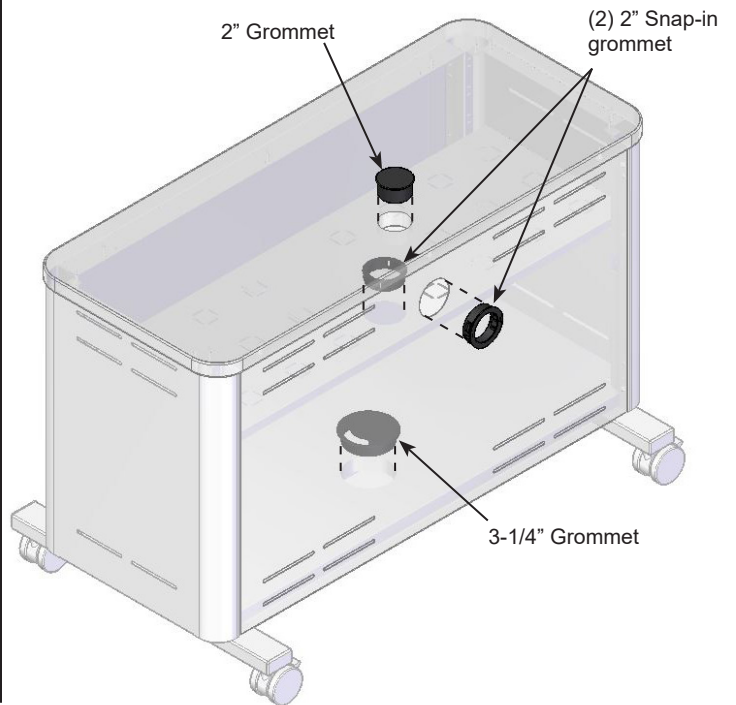

Wall Mounting (Wall-mount units only)

1. Position the Console Hub at the desired location along the wall.
2. Place temporary blocking underneath to raise up the unit to the preferred height. (*blocking not included*)
3. Make sure the Console Hub is level.
4. Using the rear half panel slots as a template, mark (4) mounting hole locations onto the wall. Slots are spaced at 4" on center. If attaching to a stud wall, be sure each hole location aligns on a stud.
5. Move Console Hub away from wall.
6. Using a 3/16" bit, drill into the wall at the (4) marked locations. (Approximately 1-1/4"D). If drilling into concrete, use a hammer drill with a 3/16" masonry bit.
7. Move Console Hub back to wall.
8. Install (4) 1/4" x 1-1/4" Tapcon fasteners with 1/4" washers and tighten securely.
9. Remove blocking.



Electric
hammer
drill

3/16"
masonry
drill bit



Level



Ratcheting
wrench
with 5/16"
socket

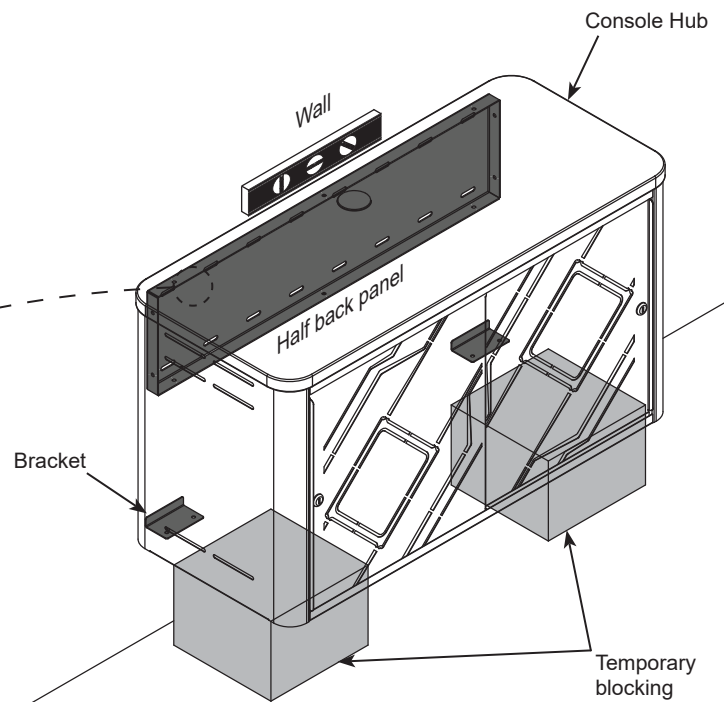
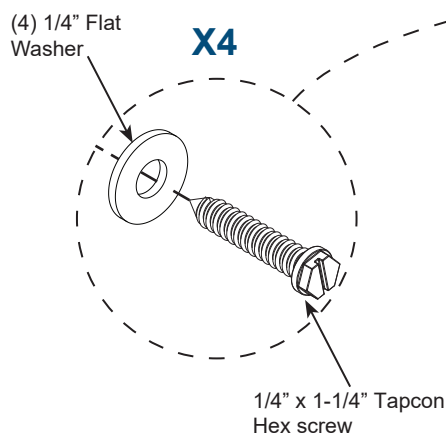



Important Safety and Care Instructions



- Read this owner's manual before assembly or operation.
- Do not allow children to move the cart.
- Proceed slowly and carefully when moving the cart.
- For indoor use only. Do not install or store the cart where it will be exposed to moisture.
- Do not block the ventilation openings.
- Avoid uneven loading of the equipment into the cart. Uneven weight distribution could cause the cart to tip when the cart is moving.
- Do not allow anyone to sit, stand, or climb on the cart.
- Use a damp, soft-cloth, or sponge, with mild soap or detergent solution to clean dirty surfaces. Do not use harsh solvents or abrasives.
- This cart is intended for institutional use. It does not have any user-serviceable parts or user-maintenance requirements. If servicing is necessary, please contact Spectrum Industries for assistance.

Warning - Relocating audio and/or video equipment to furniture not specifically designed to support audio and/or video equipment may result in death or serious injury due to the furnishing collapsing or over turning onto a child.

Warning - Death or serious injury may occur when children climb on audio and/or video equipment furniture. A remote control or toys placed on the furnishing may encourage a child to climb on the furnishing and as a result the furnishing may tip over on to the child.

Electrical Safety:

- Keep the power switch in the OFF position before plugging or unplugging from the wall outlet.
- Turn OFF the devices before plugging them into the cart.
- Ensure total device / equipment load does not exceed 12-amps.
- Do not plug the power cord into an extension cord.
- Inspect the power cords for damage before each use. Do not use power cords that are damaged.
- Unplug power cord from electrical outlet by gripping the plug. Do not unplug the power cord by pulling only on the cord.
- Do not step on, drive over, drag, or place objects on the power cord.
- For added safety, plug the cart into a grounded outlet controlled by a GFI (Ground Fault Interrupter) circuit breaker.
- Damaged electrical components can create significant hazards to users and is not covered by the warranty. Repairs should always be performed by a qualified electrician.
- Electrical devices are not toys. Children are often unaware of the hazards associated with electrical devices. This cart must always be used by adults or with adult supervision.



Consignes importantes de sécurité et d'entretien



- Lire ce guide d'utilisation avant l'assemblage ou l'utilisation.
- Interdire aux enfants de déplacer l'armoire.
- Déplacer l'armoire lentement et prudemment.
- Utilisation à l'intérieur uniquement. Ne pas assembler et ne pas ranger l'armoire dans un endroit humide.
- Ne pas boucher les prises d'air de ventilation.
- Éviter le chargement mal réparti de l'équipement sur l'armoire. Un chargement mal réparti risque de faire basculer l'armoire en déplacement.
- Interdire à quiconque de s'asseoir, de se tenir debout ou de grimper sur l'armoire.
- Passer un chiffon doux ou une éponge, imbibés de solution nettoyante ou de savon liquide doux, sur les surfaces sales. Ne pas utiliser des solvants rudes ou des abrasifs.
- Cette classe mobile est destinée à un usage collectif. Elle ne contient aucune pièce susceptible d'être réparée par l'utilisateur et ne nécessite aucun entretien de la part de celui-ci. Si une maintenance est requise, communiquer avec Spectrum Industries pour obtenir de l'aide.

Avertissement - Reloger un équipement audio ou vidéo sur un meuble non conçu pour supporter cet équipement pourrait entraîner de graves blessures, voire la mort, à la suite de l'effondrement du meuble ou de sa chute sur un enfant.

Avertissement - Un enfant qui grimpe sur un meuble d'équipement audio ou vidéo pourrait subir des blessures graves ou mortelles. Une télécommande ou des jouets placés sur le meuble risquent d'inciter un enfant à y grimper : le meuble pourrait alors basculer et écraser l'enfant.

Consignes de sécurité en électricité

- Mettre d'abord l'interrupteur sur Arrêt avant de brancher ou de débrancher la prise.
- Éteindre les appareils avant de les brancher à l'armoire.
- Assurez-vous que la charge totale appareils / équipements n'excède pas 12 A.
- Ne pas brancher le cordon d'alimentation sur une rallonge.
- Vérifier que les cordons d'alimentation sont intacts avant chaque utilisation. Ne pas les utiliser s'ils sont abîmés.
- Pour débrancher le cordon de la prise murale, saisir son bouton isolant et tirer; ne pas tirer le cordon.
- Ne pas marcher, ne pas rouler et ne pas placer des objets sur le cordon d'alimentation; ne pas le traîner.
- Pour plus de sécurité, brancher l'armoire sur une prise mise à la terre protégée par un disjoncteur de fuite de terre.
- Les composants électriques abîmés risquent d'exposer les utilisateurs à de graves dangers; ils ne sont pas couverts par la garantie. Toujours confier les réparations à un électricien qualifié.
- Les appareils électriques ne sont pas des jouets. Les enfants n'ont souvent pas conscience des dangers associés aux appareils électriques. Cette armoire doit donc être toujours utilisée par un adulte, ou sous la surveillance d'un adulte.



Instrucciones importantes de prevención de accidentes y cuidado



- Lea este manual del propietario antes de la instalación u operación.
- No permita que los niños muevan el carro.
- Proceda lenta y cuidadosamente al mover el carro.
- Solo para uso en interiores. No instale o guarde el carro donde quede expuesto a la humedad.
- No obstruya las rendijas de ventilación.
- Evite cargar el equipo de forma desigual dentro del carro. La distribución asimétrica del peso podría provocar que el carro se vuelque al momento de moverlo.
- No permita que nadie se siente, pare o suba al carro.
- Para limpiar las superficies sucias, utilice un paño, trapo suave o esponja con jabón neutro o una solución de detergente. No utilice solventes o abrasivos ásperos.
- El uso convencional de este carro es institucional. No contiene ninguna parte que pueda ser reparada ni requiere de mantenimiento por parte del usuario. Si fuera necesario darle mantenimiento, póngase en contacto con Spectrum Industries para obtener asistencia.

Advertencia: reubicar equipo de audio y/o video a un mueble que no haya sido diseñado específicamente para tal uso, puede provocar la muerte o lesiones graves debido a que puede colapsarse o volcarse sobre un niño.

Advertencia: existe peligro de muerte o lesiones graves si los niños se suben a un mueble de equipo de audio y/o video. Un control remoto o juguete colocado sobre el mueble puede alentar a un niño a subirse y provocar que el mueble se vuelque sobre el chico.

Prevención de accidentes eléctricos:

- Mantenga el interruptor de alimentación en la posición de OFF [apagado], antes de enchufarlo o desenchufarlo del tomacorriente de pared.
- Apague los dispositivos antes de enchufarlos al carro.
- Revise que la carga total del dispositivo o del equipo no exceda los 12 amperios.
- No enchufe el cable de alimentación a un cable de extensión.
- Revise que el cable de alimentación no tenga ningún daño antes de utilizarlo. No utilice cables de alimentación que estén dañados.
- Desconecte el cable de alimentación de la toma eléctrica sosteniendo firmemente el enchufe. No desconecte el cable de alimentación tirando solamente del cable.
- No se pare, circule, jale o coloque ningún objeto sobre el cable de alimentación.
- Para mayor seguridad, enchufe el carro a una conexión a tierra controlada por un interruptor de circuito GFI (interruptor de fallas de conexión a tierra).
- Los componentes eléctricos dañados pueden implicar riesgos de importancia para los usuarios, que no cubrirá la garantía. Un electricista calificado es quien deberá realizar siempre las reparaciones.
- Los dispositivos eléctricos no son juguetes. Los niños generalmente no están conscientes de los riesgos asociados con los dispositivos eléctricos. Este carro lo deberán utilizar siempre personas adultas o bajo su supervisión.

Warranty

We will make it right for you!

Thanks for choosing Spectrum! Spectrum is committed to provide complete customer satisfaction. Each of our products is manufactured from the best materials available and each product is stringently monitored throughout the production process through our P.A.C.E. program (Product Assurance to meet Customer Expectations).

We expressly warrant that Spectrum products will be of good quality and workmanship and free from defect for the period set out in the warranty from the date of delivery.

For a listing of all product specific warranty terms please visit our website at:

<https://www.spectrumfurniture.com/en/resources/purchasing-terms-warranty>

1-800-235-1262

Toll-free HELPLINE

spectrum@spectrumfurniture.com