

Assembly Instructions

⚠ Important ⚠

Before you begin, read and comply with all safety and operating instructions, and ensure all parts and correct quantities are included.

Any parts damaged during shipment must be reported within 5 days of receipt. To report information regarding missing parts or damage, to purchase parts or accessories, or if you have any questions, please contact us.

www.spectrumfurniture.com
800-235-1262, 715-723-6750

Thank you for purchasing Spectrum products!

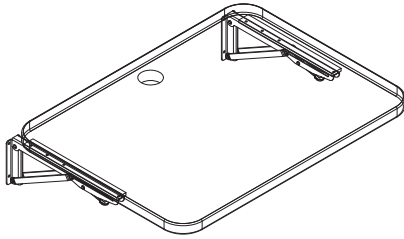

(1) Flip-up shelf assembly



(1) 039622
2" Grommet



(8) 0100167
8-32 x 1/2" PH
Thread-cutting screw

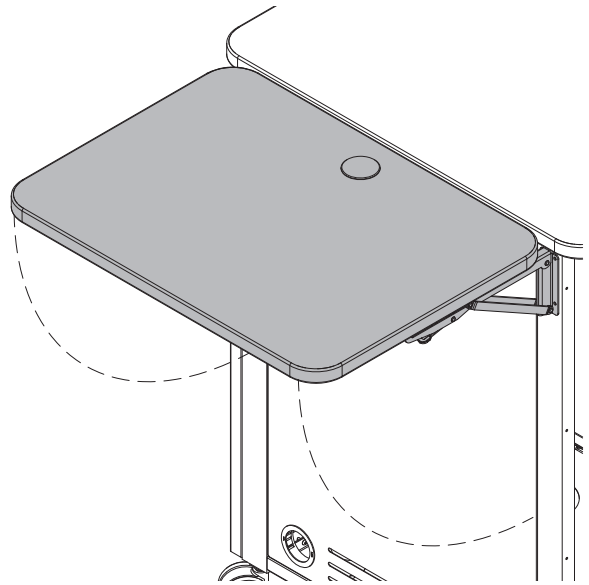

Flip-up Shelf for Freedom One eLift™ 55543



Installation

1. Determine which side of the equipment rack you want the shelf installed. (Left or right).
2. Extend each shelf bracket by depressing the release lever and lifting until it locks into the 90° position. **Figure 1.**
3. Using a second person to support the shelf, install the (8) 8-32 x 1/2" PH thread-cutting screws into the side panel. Do not tighten until all screws have been installed.
4. Tighten all screws securely.
5. Install 2" grommet.

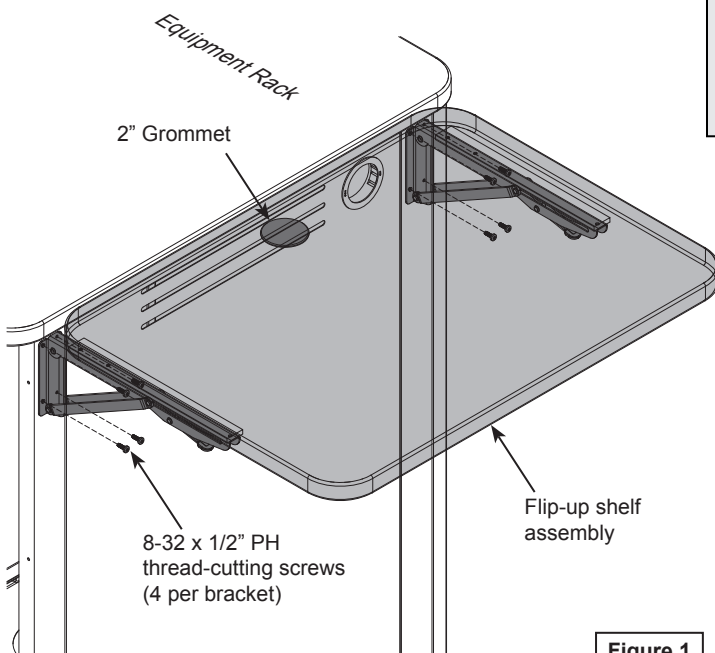

Figure 1

⚠ CAUTION ⚠

Keep clear of pinch points during shelf movement.
Do not exceed 35 lb [15.9 kg] of weight on shelf.
Not for use on stand-alone equipment racks.

Operation

The shelf will automatically lock into place when lifted into the horizontal position with the levers released. **Figure 2.** To lower or flip-up the shelf, press and hold the shelf bracket levers while slowly lowering or raising the shelf. Do not move the lectern while the shelf is in the horizontal position.

Note: Power and communication wiring for document cameras, laptop computers, and / or projectors placed on the flip-up shelf should be routed on top of the audience-side of the shelf. Use of the shelf grommet hole for wiring will result in pinching of the cords when the shelf is folded.

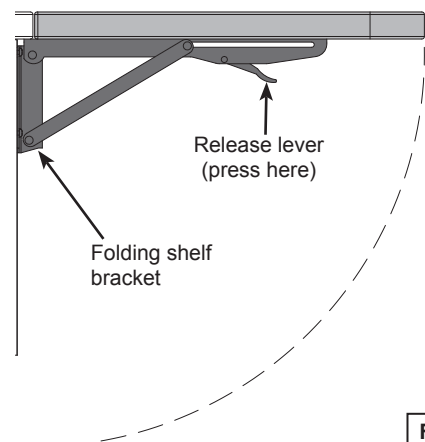

Figure 2