

## Optio Collaboration™ Table

37132

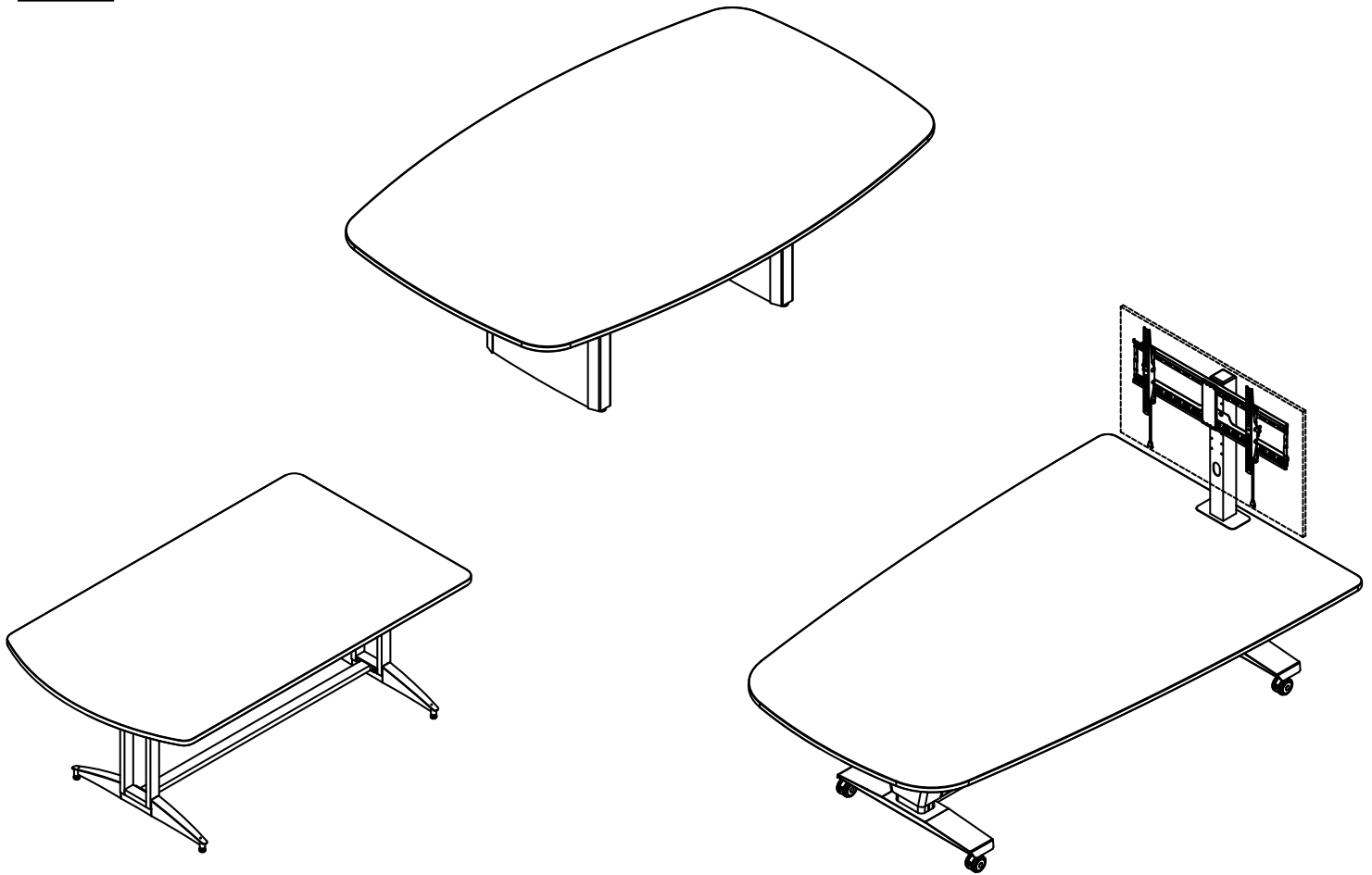

Important	Important	Importante
<p>Before using this product:</p> <ul style="list-style-type: none"> <li>• Read this manual</li> <li>• Comply with all safety and operating instructions</li> <li>• Ensure all parts and correct quantities are included</li> </ul> <p>Any parts damaged during shipment must be reported within 5 days of receipt. To report information regarding missing parts or damage, to purchase parts or accessories, or if you have any questions, please contact us.</p> <p>Thank you for purchasing Spectrum products!</p>	<p>Avant d'utiliser ce produit:</p> <ul style="list-style-type: none"> <li>• Veuillez à lire ce guide</li> <li>• Respectez les consignes de sécurité et d'utilisation</li> <li>• Vérifiez que vous disposez de toutes les pièces nécessaires à l'installation</li> </ul> <p>Les pièces endommagées pendant le transport doivent faire l'objet d'un rapport dans les 5 jours de leur réception. Veuillez prendre contact avec nous si des pièces manquent ou sont abîmées, si vous avez des questions, ou encore pour acheter des pièces ou des accessoires.</p> <p>Merci pour votre achat d'un produit Spectrum!</p>	<p>Antes de utilizar este producto:</p> <ul style="list-style-type: none"> <li>• Lea este manual</li> <li>• Cumpla con todas las instrucciones de prevención de accidentes y operativas</li> <li>• Revise que todas las partes y las cantidades correctas estén incluidas</li> </ul> <p>Si alguna parte se dañó durante el embarque, deberá reportarla en un lapso de 5 días a partir de la recepción. Para reportar cualquier información sobre partes faltantes o dañadas, para adquirirlas o comprar accesorios, o bien, si tiene alguna duda, póngase en contacto con nosotros.</p> <p>¡Gracias por adquirir productos Spectrum!</p>



[www.spectrumfurniture.com/en/products/optio-collaboration-table](http://www.spectrumfurniture.com/en/products/optio-collaboration-table)

Owner's Manual Le manuel du propriétaire El manual del propietario	Specs Spécifications Especificaciones	Video Vidéo Vídeo
--	---	-------------------------



800-235-1262

1

# Remove from pallet



X 4



## Tables with eLift legs

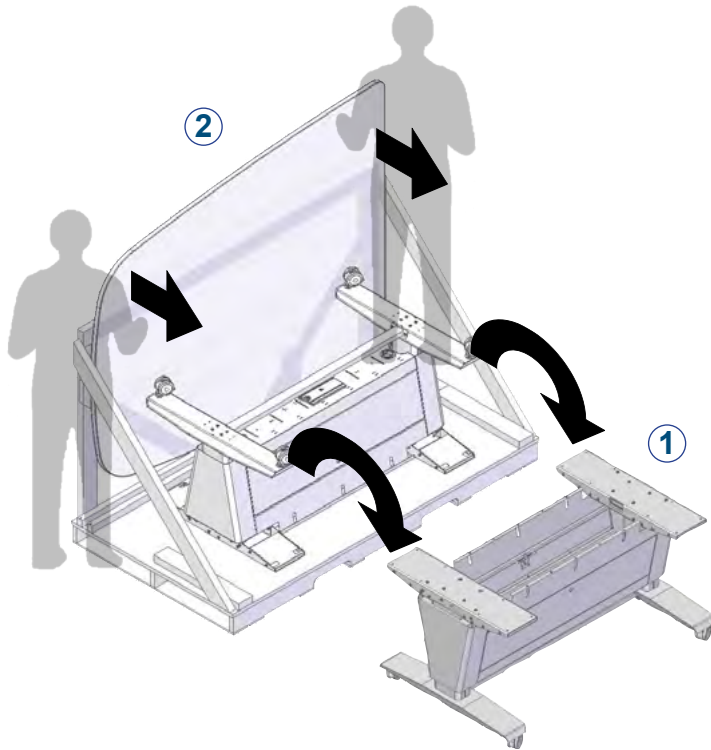

## Tables with slab or T-legs

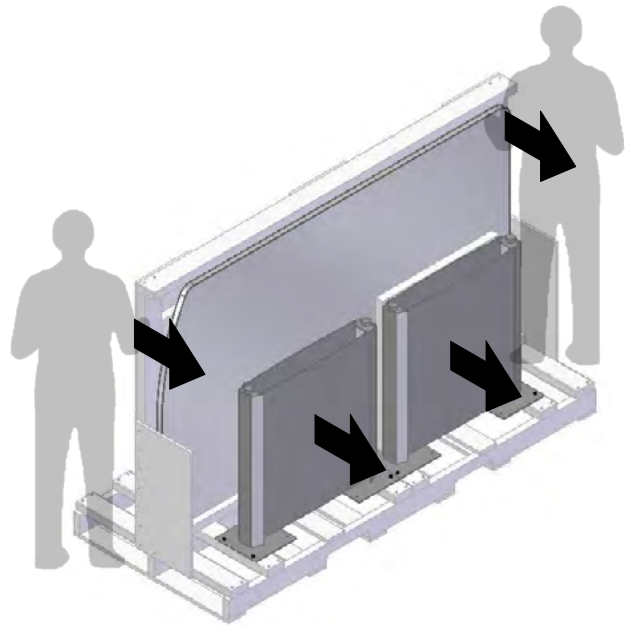

## 2 Set work surface on base

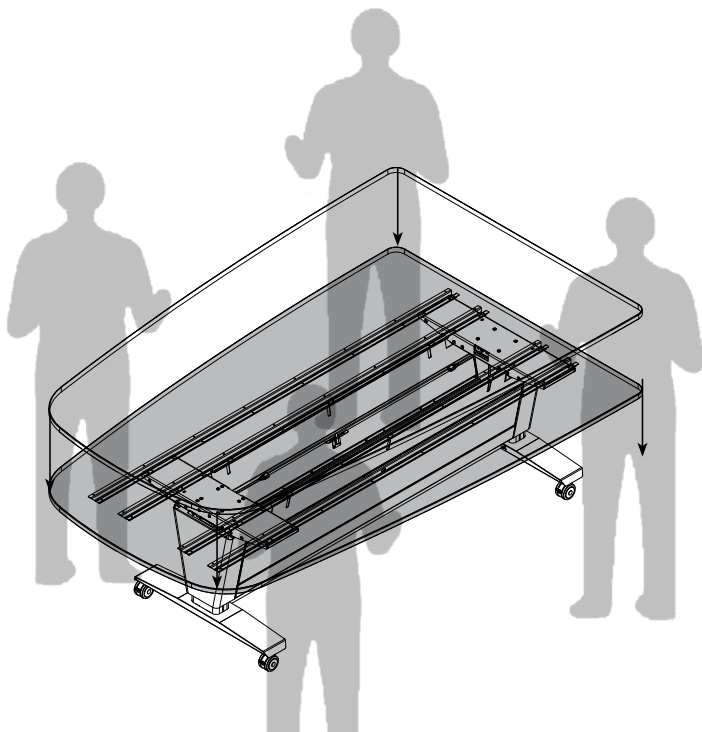

## 2 Attach legs to work surface braces

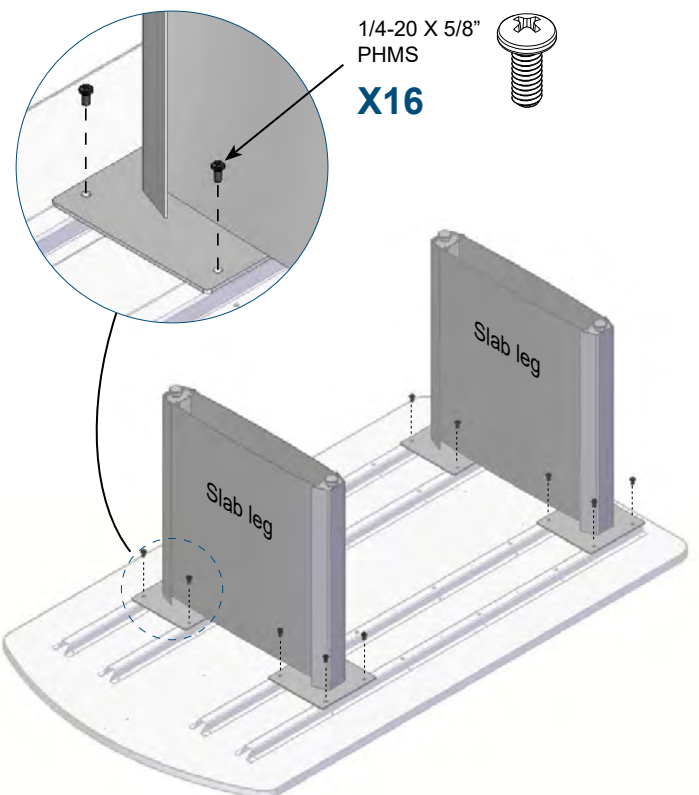

**⚠** Note: If installing a display stand, do not secure work surface to the base yet. The work surface will be aligned and secured after the display stand is attached.

3 Attach cord channel (if equipped)

4 Flip slab / T-leg table upright

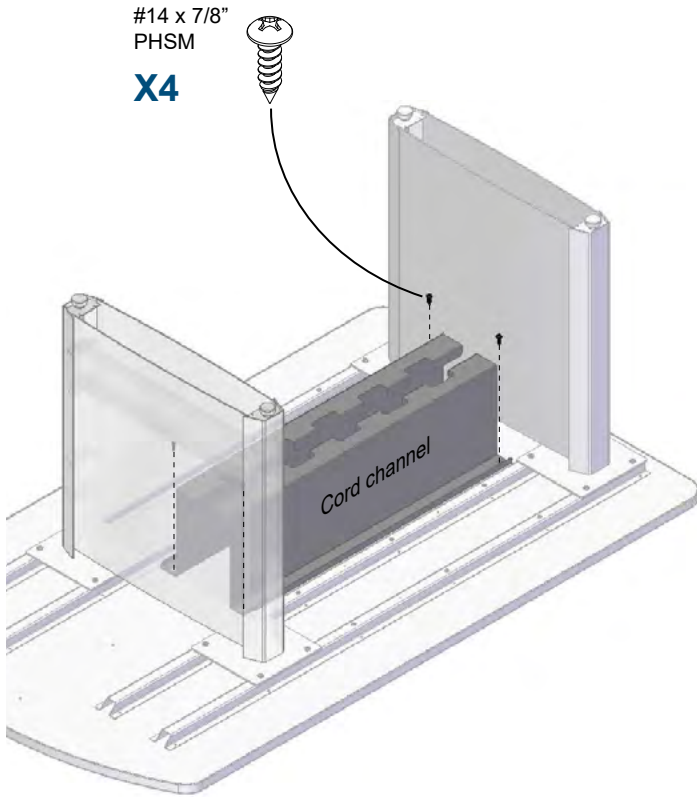

⚠ CAUTION

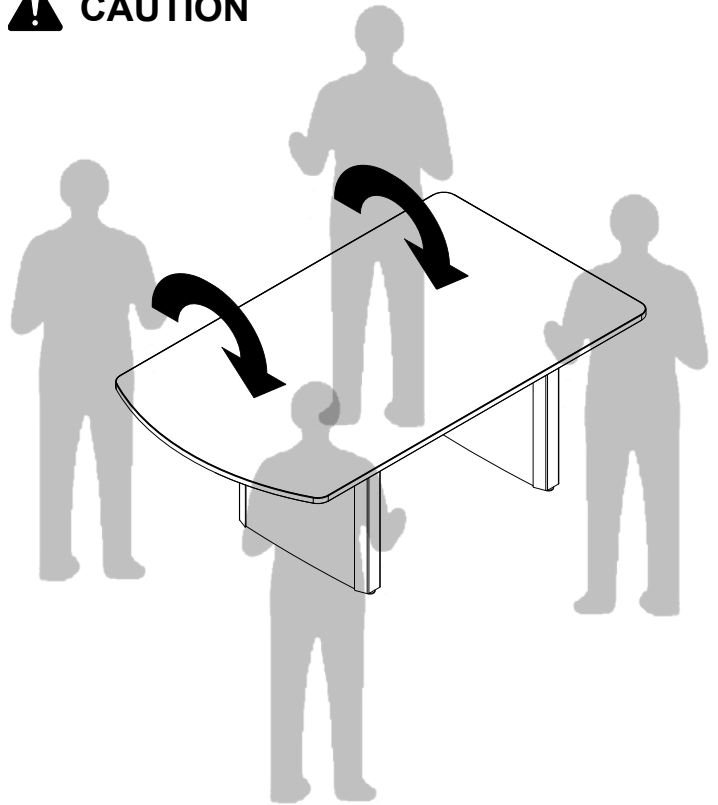

5 Install display stand (if equipped)

6 Install filler panel (if included)

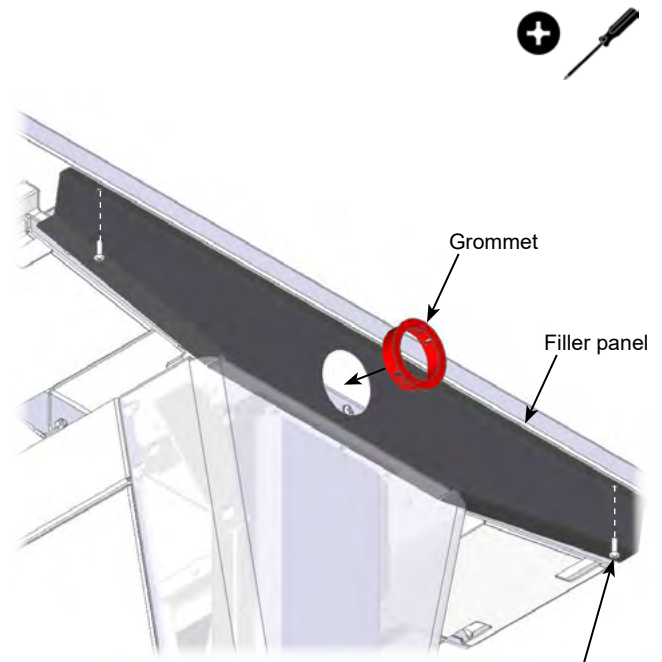
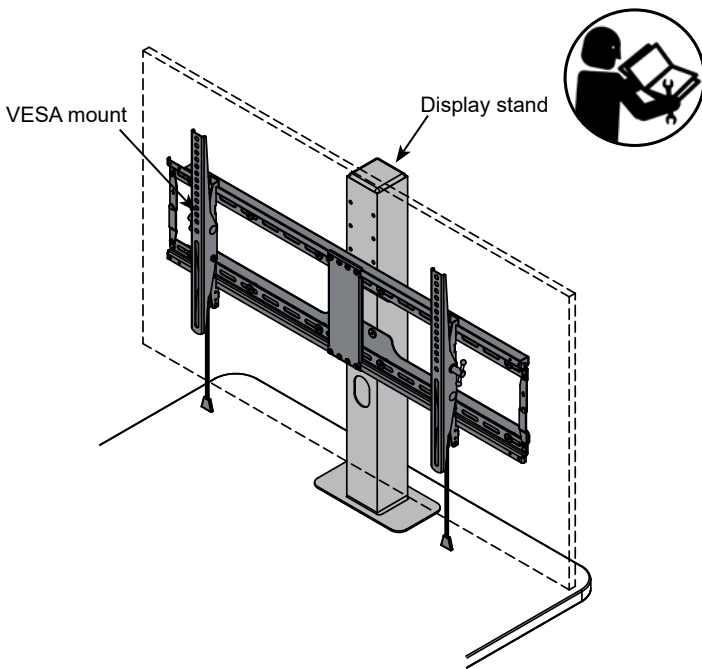

⚠ Tables with eLift legs only:  
After the display stand is secured to the worksurface, align and secure the worksurface assembly to the eLift base.

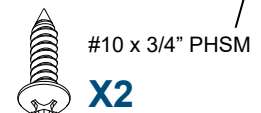

## 7 Route wiring (if equipped with modules)

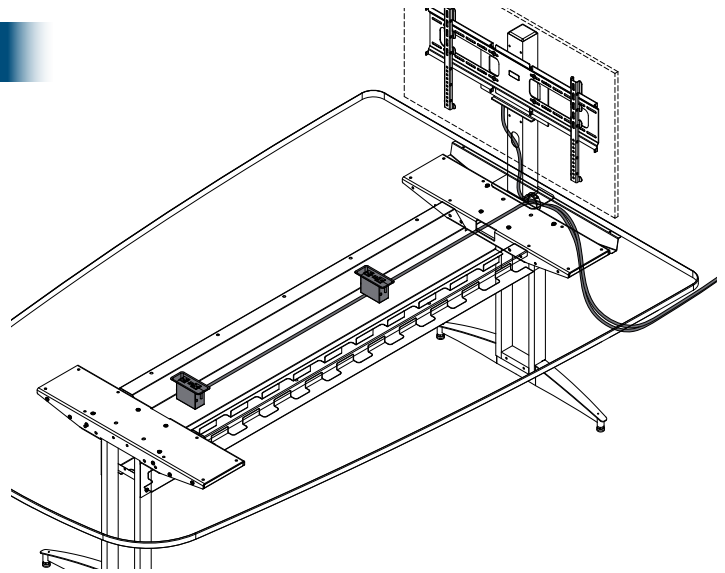

## 8 Install control button (eLift legs only)

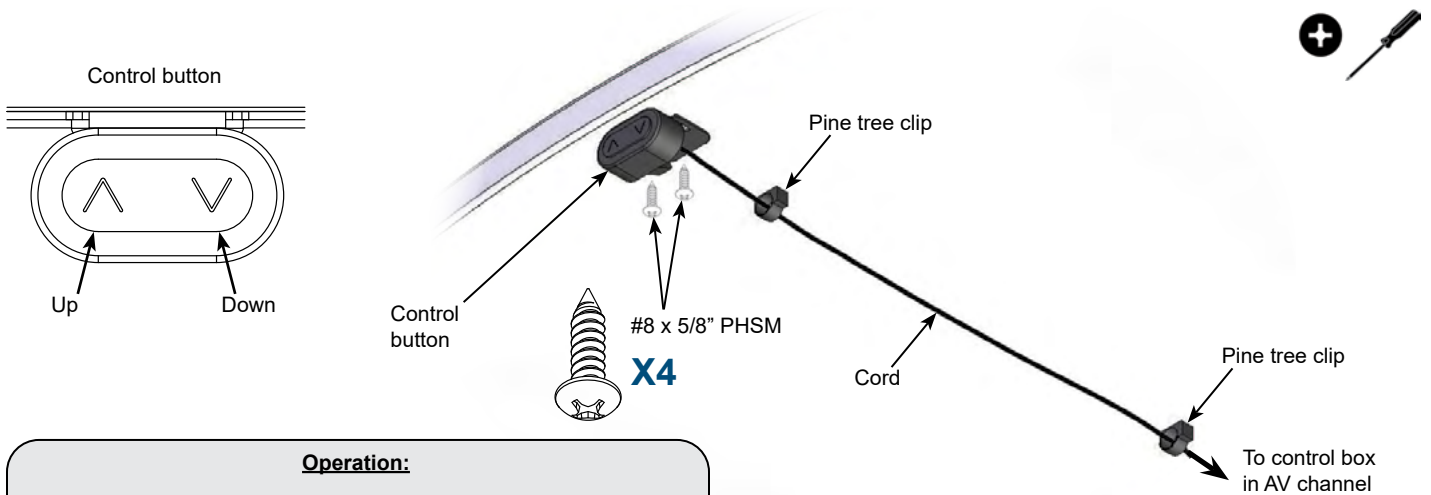

### Operation:

1. Plug the 15-amp power cord into a wall outlet.
2. Locate the "Up" and "Down" buttons on the control pad.
3. To raise or lower the worksurface, press and hold the "up" or "down" arrow keys on the control pad until the worksurface reaches the desired height. The worksurface maximum height is 42", minimum height is 29".

Keep clear of pinch points during worksurface movement.

### Reset Procedure:

1. Unplug, then re-plug the power cord into a wall outlet.
2. Make sure all lift mechanism wire connections are in place and secure.
3. Remove anything located under the worksurface.
4. Press and hold the "Down" button to lower the worksurface to the lowest "work" position until it stops moving.
5. Release the "Down" button.
6. Press and hold the "Down" button again until the worksurface bottoms-out, slightly rises, and stops moving. The worksurface must be completely lowered before resuming operation.

**Note: If the worksurface does not lower when doing this step, release the "Down" button, and retry step 6.**

7. Release the "Down" button. The lift mechanism has now been reset and the worksurface can be adjusted normally.

Note: Additional sets of pre-drilled mounting holes are also available under the worksurface for control button mounting.



**CAUTION**

Keep clear of pinch points during worksurface movement.  
Note: The lift actuators are rated at a maximum capacity of 180 lb each.



**CAUTION**

**Always unplug the eLift before working under the worksurface.**

Although this table utilizes an anti-collision feature that briefly stops and reverses the motion of the table in the event of an obstruction, **Use caution when raising or lowering the worksurface! Do not** sit at, under, or on the worksurface when operating the lift mechanism and be sure table movement does not interfere with objects or people.



**CAUTION**

**USE CAUTION WHEN RAISING OR LOWERING TABLE!**

# eLift Leg Troubleshooting Guide

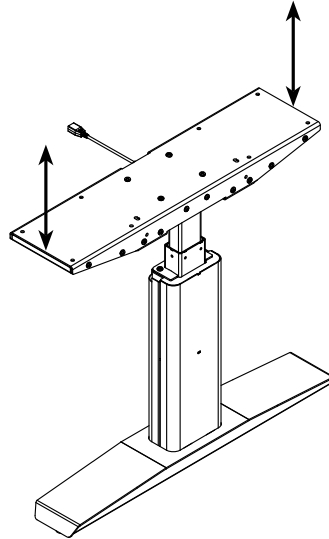

Symptom	Problem	Solution
eLift legs will not operate	Loss of power	Be sure unit is plugged into a live circuit.
	Loose electrical connections	Make sure all electrical connections are securely plugged into the control box.
	Object encountered under work surface	<ol style="list-style-type: none"> <li>1. Raise the work surface by pressing the "Up" button.</li> <li>2. Remove any items sitting below the work surface.</li> <li>3. Reset the lift mechanism (see below for procedure.)</li> </ol>
	Misaligned actuators	<p style="text-align: center;"><b><u>Reset Procedure:</u></b></p> <p>This table has a load-sensing, anti-collision feature in the controller that actively locks out the lift mechanism when unbalanced loads are encountered; i.e. weight from a person sitting on one side of the table. The following reset procedure should be performed if the lift mechanism becomes locked out and the table does not extend or retract.</p> <p style="text-align: center;"><b>⚠ WARNING ⚠</b></p> <p><b><u>The anti-collision feature does not function in RESET MODE.</u></b> Do not sit at, under, or on the work surface while resetting the lift mechanism. Be sure the table movement does not interfere with objects or people. Do not place <u>any</u> items under the work surface.</p> <ol style="list-style-type: none"> <li>1. Unplug, then re-plug the power cord into a wall outlet.</li> <li>2. Make sure all lift mechanism wire connections are in place and secure.</li> <li>3. Remove <u>anything</u> located under the work surface.</li> <li>4. Press and hold the "Down" button to lower the work surface to the lowest "work" position until it stops moving.</li> <li>5. Release the "Down" button.</li> <li>6. Press and hold the "Down" button for 30 seconds. The work surface will lower, bottom-out, slightly rises, then stop moving. The work surface must be completely lowered before resuming operation.</li> </ol> <p><b>Note: If the work surface does not lower when doing this step, release the "Down" button, and retry step 6.</b></p> <ol style="list-style-type: none"> <li>7. Release the "Down" button. The lift mechanism has now been reset and the work surface can be adjusted normally.</li> </ol>



## Important Safety and Care Instructions



- Read these instructions before assembly or operation.
- Do not allow children to move the table.
- Proceed slowly and carefully when moving the table.
- For indoor use only. Do not install or store the table where it will be exposed to moisture.
- Do not block the ventilation openings.
- Avoid uneven loading of the equipment into the table. Uneven weight distribution could cause the table to tip when the table is moving.
- Do not allow anyone to sit, stand, or climb on the table.
- Use a damp, soft-cloth, or sponge, with mild soap or detergent solution to clean dirty surfaces. Do not use harsh solvents or abrasives.
- This table is intended for institutional use. It does not have any user-serviceable parts or user-maintenance requirements. If servicing is necessary, please contact Spectrum Industries for assistance.

**Warning** - Relocating audio and/or video equipment to furniture not specifically designed to support audio and/or video equipment may result in death or serious injury due to the furnishing collapsing or over turning onto a child.

### Electrical Safety:

- Do not plug the power cord into an extension cord.
- Inspect power cords for damage before each use. Do not use power cords that are damaged.
- Unplug power cord from electrical outlet by gripping the cord. Do not unplug the power cord by pulling only on the cord.
- Do not step on, drive over, drag, or place objects on the power cord.
- For added safety, plug the table into a grounded outlet controlled by a GFI (Ground Fault Interrupter) circuit breaker.
- Electrical devices are not toys. Children are often unaware of the hazards associated with electrical devices. This table must always be used by adults or with adult supervision.

**Warning** - Death or serious injury may occur when children climb on audio and/or video equipment furniture. A remote control or toys placed on the furnishing may encourage a child to climb on the furnishing and as a result the furnishing may tip over on to the child.



## Consignes importantes de sécurité et d'entretien



- Lire ce guide d'utilisation avant l'assemblage ou l'utilisation.
- Interdire aux enfants de déplacer le tableau.
- Déplacer le tableau lentement et prudemment.
- Utilisation à l'intérieur uniquement. Ne pas assembler et ne pas ranger le tableau dans un endroit humide.
- Ne pas boucher les prises d'air de ventilation.
- Éviter le chargement mal réparti de l'équipement sur le tableau. Un chargement mal réparti risque de faire basculer le tableau en déplacement.
- Interdire à quiconque de s'asseoir, de se tenir debout ou de grimper sur le tableau.
- Passer un chiffon doux ou une éponge, imbibés de solution nettoyante ou de savon liquide doux, sur les surfaces sales. Ne pas utiliser des solvants rudes ou des abrasifs.
- Ce tableau est destiné à un usage institutionnel. Il ne contient aucune pièce susceptible d'être réparée par l'utilisateur et ne nécessite aucun entretien de la part de celui-ci. Si une maintenance est requise, communiquer avec Spectrum Industries pour obtenir de l'aide.

**Avertissement** - Reloger un équipement audio ou vidéo sur un meuble non conçu pour supporter cet équipement pourrait entraîner de graves blessures, voire la mort, à la suite de l'effondrement du meuble ou de sa chute sur un enfant.

### Consignes de sécurité en électricité

- Ne pas brancher le cordon d'alimentation sur une rallonge.
- Vérifier que les cordons d'alimentation sont intacts avant chaque utilisation. Ne pas les utiliser s'il sont abîmés.
- Pour débrancher le cordon de la prise murale, saisir son bouton isolant et tirer; ne pas tirer le cordon.
- Ne pas marcher, ne pas rouler et ne pas placer des objets sur le cordon d'alimentation; ne pas le traîner.
- Pour plus de sécurité, brancher le tableau sur une prise mise à la terre protégée par un disjoncteur de fuite de terre.
- Les appareils électriques ne sont pas des jouets. Les enfants n'ont souvent pas conscience des dangers associés aux appareils électriques. Ce le tableau doit donc être toujours utilisé par un adulte, ou sous la surveillance d'un adulte.

**Avertissement** - Un enfant qui grimpe sur un meuble d'équipement audio ou vidéo pourrait subir des blessures graves ou mortelles. Une télécommande ou des jouets placés sur le meuble risquent d'inciter un enfant à y grimper : le meuble pourrait alors basculer et écraser l'enfant.



## Instrucciones importantes de prevención de accidentes y cuidado



- Lea este manual del propietario antes de la instalación u operación.
- No permita que los niños muevan el mesa.
- Proceda lenta y cuidadosamente al mover el mesa.
- Solo para uso en interiores. No instale o guarde el mesa donde quede expuesto a la humedad.
- No obstruya las rendijas de ventilación.
- Evite cargar el equipo de forma desigual dentro del mesa. La distribución asimétrica del peso podría provocar que el mesa se vuelque al momento de moverlo.
- No permita que nadie se siente, pare o suba al mesa.
- Para limpiar las superficies sucias, utilice un paño, trapo suave o esponja con jabón neutro o una solución de detergente. No utilice solventes o abrasivos ásperos.
- El uso convencional de este mesa es institucional. No contiene ninguna parte que pueda ser reparada por el usuario ni requiere de mantenimiento por parte de éste. Si fuera necesario darle mantenimiento, póngase en contacto con Spectrum Industries para obtener asistencia.

**Advertencia:** reubicar equipo de audio y/o video a un mueble que no haya sido diseñado específicamente para tal uso, puede provocar la muerte o lesiones graves debido a que puede colapsarse o volcarse sobre un niño.

### Prevención de accidentes eléctricos:

- No enchufe el cable de alimentación a un cable de extensión.
- Revise que los cables de alimentación no tengan ningún daño antes de cada uso. No utilice cables de alimentación que estén dañados.
- Desenchufe el cable de alimentación del tomacorriente eléctrico sosteniendo el cable firmemente. No desenchufe el cable de alimentación jalando únicamente del cable.
- No se pare, circule, jale o coloque ningún objeto sobre el cable de alimentación.
- Para mayor seguridad, enchufe el mesa a una conexión a tierra controlada por un interruptor de circuito GFI (interruptor de fallas de conexión a tierra).
- Los dispositivos eléctricos no son juguetes. Los niños generalmente no están conscientes de los riesgos asociados con los dispositivos eléctricos. Este mesa lo deberán utilizar siempre personas adultas o bajo su supervisión.

**Advertencia:** existe peligro de muerte o lesiones graves si los niños se suben a un mueble de equipo de audio y/o video. Un control remoto o juguete colocado sobre el mueble puede alentar a un niño a subirse y provocar que el mueble se vuelque sobre el chico.

## Warranty

### **We will make it right for you!**

Thanks for choosing Spectrum! Spectrum is committed to provide complete customer satisfaction. Each of our products is manufactured from the best materials available and each product is stringently monitored throughout the production process through our P.A.C.E. program (Product Assurance to meet Customer Expectations).

We expressly warrant that Spectrum products will be of good quality and workmanship and free from defect for the period set out in the warranty from the date of delivery.

**For a listing of all product specific warranty terms please visit our website at:**

<https://www.spectrumfurniture.com/en/resources/purchasing-terms-warranty>

**1-800-235-1262**

Toll-free HELPLINE

**[spectrum@spectrumfurniture.com](mailto:spectrum@spectrumfurniture.com)**