

Technical Specifications

55552

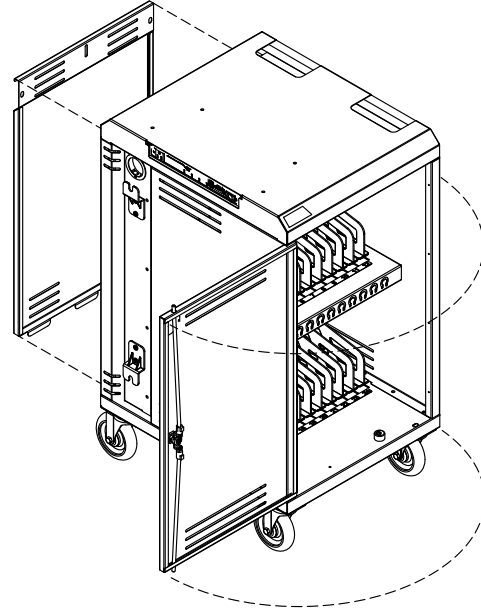

Use the Connect24 Cart to store, transport, and charge up to 24 devices. Three charging options are available. Flexible dividers protect the devices. The overhead wire management aids the wiring integration and allows the charging plugs to hang in front of each device. The cart's compact footprint and top handles provide easy mobility. The economical Connect24 Cart is made with heavy-gauge steel for security and powder-coated for a durable, long-lasting finish. Locking door and panel increase security.

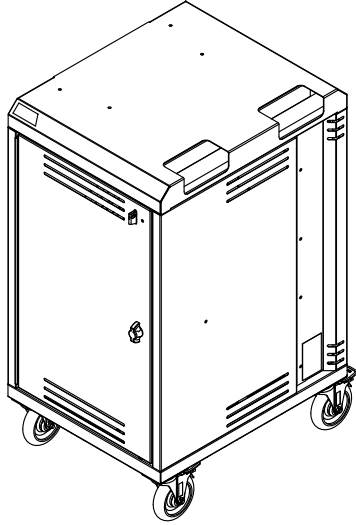

Features and Benefits

- Stores, charges, and transports up to 24 devices (most Chromebooks, tablets*, and notebooks up to 15.6" diagonal)
- 1.3"W x 17.65"D x 13"H storage bay
- Numbered storage bays
- Small cart footprint (20.4"W x 25"D) saves valuable space
- Durable ABS plastic dividers protect devices from scratching (dividers are removable to provide storage space for thicker devices)
- Recessed cord wrap design eliminates damage through doorways
- Heavy gauge student-side door features a recessed dual-bolt steel lock with padlock hasp. (Padlock not included).
- Heavy gauge instructor-side panel has a recessed padlock hasp for security. (Padlock not included).
- Devices and students are separated from AC line voltage
- Superior, all-metal overhead cord management system keeps charge cords organized above each bay
- Replaceable, IEC (quick-release) 8' nominal 14 AWG, 3-wire power cord and external recessed cord wrap brackets provide easy power access
- Four inboard 5" balloon wheel plate casters (two locking, two non-locking) with metal construction and non-marring rubber provide easy rolling, and quiet transport (rated for 300 lb each)
- Integrated handles in top panel provides control and maneuverability
- Cart ships fully-assembled for quick, simple integration and deployment
- Durable powder coated steel chassis provides a long-lasting finish
- ETL listed in the US and Canada for cart, electrical, and timers
- Warranted to be free of all defects in materials and workmanship for 10 years, electrical system 2 years
- Designed and assembled in Chippewa Falls, WI, USA

Connect24 available with:

- Power switch provides continuous power to both power units (non current-sensing) ***For most power adapters up to 60W**
- eLogix™ timer provides cycling power to both power units (non current-sensing) ***For most power adapters up to 120W**
- PowerProdigy™ timer that senses current from both power units and distributes power (up to 10A) to the least-charged devices first (where charging is needed most) ***For most power adapters up to 120W**
- Cart is available prewired with USB-C PD chargers

- Two vertically adjustable (125V~/12A, 60Hz) 12-outlet universal power units work with most inline adapters
- External power switch provides easy-access for safe power connection / disconnection
- External LED illumination on timers indicate charge status while doors are closed
- Ventilated doors and side panels keep devices and chargers cool, preventing overheating, and extending device life

55552-DBW - Connect24 w/ Power Switch

55552-DBX - Connect24 w/ eLogix™ timer

55552-DBV - Connect24 w/ PowerProdigy™ timer

55552-USBC - Connect24 w/ USB-C PD charging / Power Switch (prewired)

This cart is designed to hold up to 24 Chromebooks, tablets, or notebooks.

Color Options

Warm Gray



Black
(top panel)

*Accessory power plug may be needed
revised 9/19/22

Construction

- 16-gauge top cover
- 20-gauge doors, side panels, power-side panel, and base
- All metal components are finished with a scratch-resistant powder coat epoxy
- ABS plastic dividers
- This cart is factory-assembled, packaged, and shipped on its own skid

Specifications

Capacity	24 devices. (Most Chromebooks, tablets*, or notebooks) <i>*Accessory power plug may be needed</i>	
Storage bays (nominal)	1.3"W [3.3 cm] x 17.65"D [44.84 cm] x 13"H [33 cm]	
Electrical	<ul style="list-style-type: none"> • Two 12-outlet power units • 125V~/12A, 60Hz • 15-amp breaker 	<ul style="list-style-type: none"> • IEC quick-release (replaceable) 8' nominal, 14 AWG, 3-wire power cord • Locking power-side panel isolates and separates electrical line voltage from students
Charging options (See p.4 for specs)	<p>⚠ Note: The customer should be aware of the amp draw of the devices used with this cart-especially when maxing out the storage and charging capacity. Exceeding 15 amps will trip the circuit breaker. Please consult the owners manual of your specific device for power consumption information.</p>	
5" Balloon Wheels	Weight capacity 300 lb [136.2 kg] each (two locking, two non-locking)	
Certifications / Compliance	<ul style="list-style-type: none"> • ETL listed in US and Canada Cart (62368-1), Power strips (962A), Timers (60950-1) 	<ul style="list-style-type: none"> • Meets or exceeds applicable ANSI-BIFMA test standards
Unit weight (nominal)	105 lb [47.7 kg]	
Shipping weight (nominal)	135 lb [61.3 kg]	

Specifications subject to change without notice

Numbered storage bays

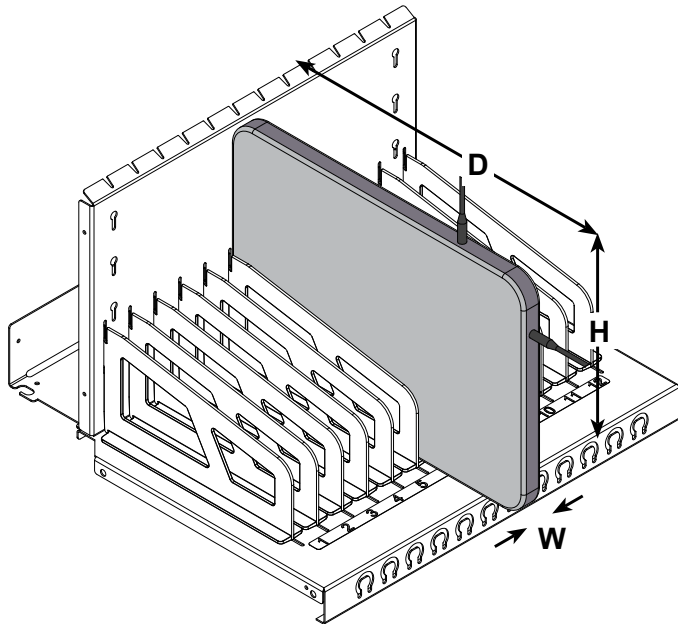

Devices must be placed in the bays with the charge plug on one of the two exposed edges shown.

Note: Do not place items weighing more than 50 lb [22.7 kg] on the top surface. Please remove or secure items before moving cart.

USB-C PD Charger
(USB-C PD prewired cart only)



- Specifications:
- Model: HA712
 - Input: 100-240V ~ 50/60Hz 1.5A
 - Output (USB-C PD): 5V~3A, 9V~3A, 12V~3A, 15V~3A, 20V~3.25A
 - Dimensions: 1.97" x 1.97" x 1.10" (50mm x 50mm x 28mm)
 - Net Weight: 3.42 oz [97 g]

5" Balloon Wheel

Note: (2) locking, and (2) non-locking casters are included on each cart.

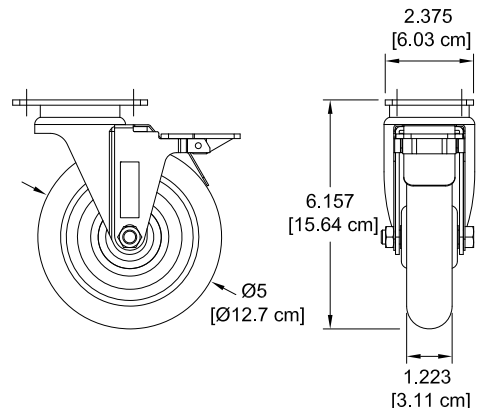

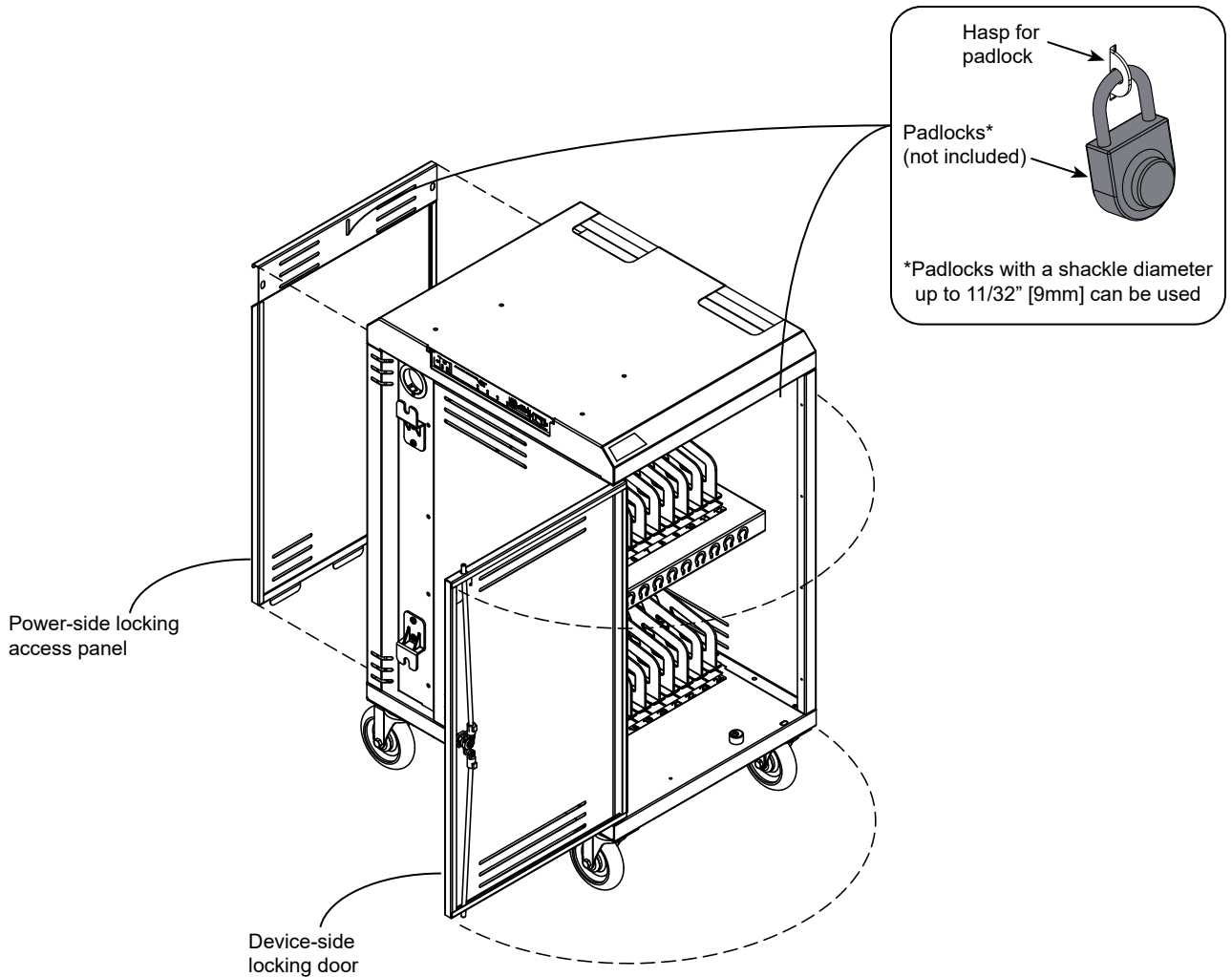

Electrical Options

Connect24™ Electrical comparison			
PowerProdigy™ Timer	eLogix™ Timer	Power Switch	
✓		✓	External auxiliary outlet
✓	✓	✓	Internal auxiliary outlet
✓	✓	✓	External on/off switch
✓			Load-sensing technology
	✓		2 bank
✓		✓	4 bank
✓	✓		Max charging capacity: 2,880 watts (on Connect24, most power adapters up to 120W)
		✓	Max charging capacity: 1,440 watts (on Connect24, most power adapters up to 60W)
✓	✓		LED lights indicate charging status
✓	✓	✓	ETL certified to 60950-1

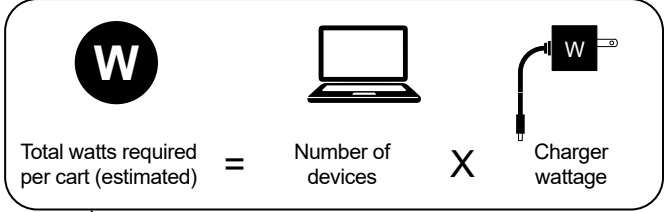

Power Switch (W)

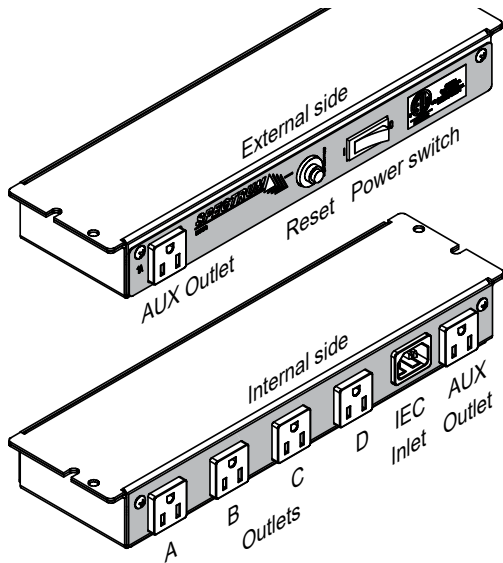

The Power Switch provides continuous power to all power units. Use with lower amp-draw devices. Maximum charging capacity: 1,440 watts.

- Four continuous power-unit dedicated outlets (labeled A, B, C, D)
- Two auxiliary outlets (1 external, 1 internal)
- ETL recognized (certified to 60950-1)

Input:	125V~/12A, 60Hz
Breaker:	20A, 250 VAC
Outlets:	(A, B, C, D) up to 12A
Auxiliary outlets:	1A each (controlled by main power switch)
Power Cord:	IEC quick-release (replaceable) 8' nominal, 14 AWG, 3-wire
Power switch:	20A (externally accessible)

eLogix™ Timer (X)

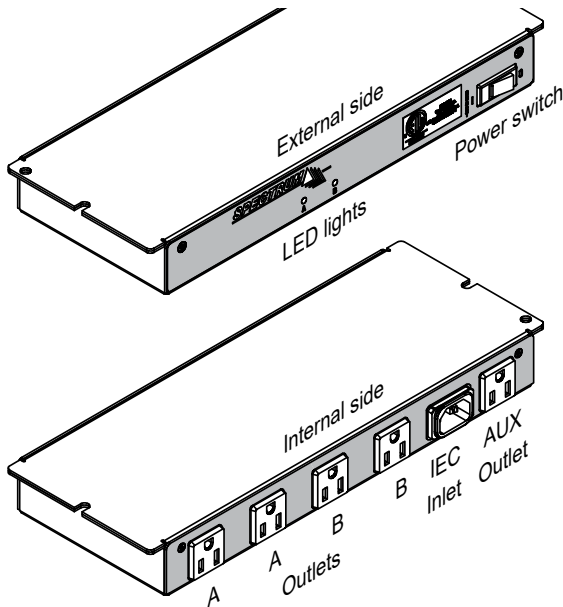

The eLogix™ timer charges one half of the devices for 15 minutes, then charges the second half of the devices for another 15 minutes. This cycling occurs automatically and is not adjustable. Maximum charging capacity: 2,880 watts on Connect24.

- Two timed power-unit dedicated outlets (labeled A, B) (up to 12A power output)
- Two green LED lights indicate charging activity status
- One auxiliary outlet (internal)
- ETL recognized (certified to 60950-1)

Input:	125V~/12A, 60Hz
Breaker:	20A, 250 VAC
Cycling interval:	15 minutes
Cycling outlets:	2 timed (A, B) up to 12A
Auxiliary outlet:	1A (controlled by main power switch)
Power Cord:	IEC quick-release (replaceable) 8' nominal, 14 AWG, 3-wire
Power switch:	20A (externally accessible)

PowerProdigy™ Timer (V)

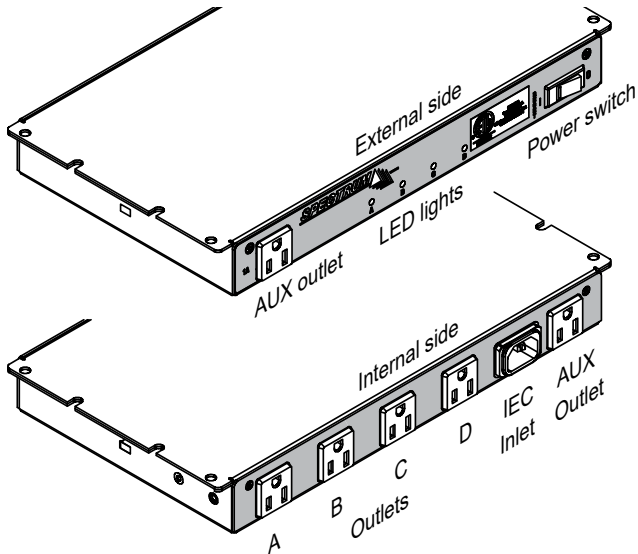

Use with higher amp-draw devices. Maximum charging capacity: 4,800 watts on Connect24.

- Smart charging senses current and distributes power to the power units requiring it most
- Four green LED lights indicate charging activity status of each power unit
- Four timed power unit-dedicated outlets (labeled A, B, C, D) controlled by logic board
- Two auxiliary outlets (1 external, 1 internal)
- ETL recognized (certified to 60950-1)

Input:	125V~/12A, 60Hz
Breaker:	20A, 250 VAC
Cycling interval:	15 minutes
Cycling outlets:	4 timed (A, B, C, D) up to 10A
Auxiliary outlets:	1A each (controlled by main power switch)
Power Cord:	IEC quick-release (replaceable) 8' nominal, 14 AWG, 3-wire
Power switch:	20A (externally accessible)

Connect24 Cart

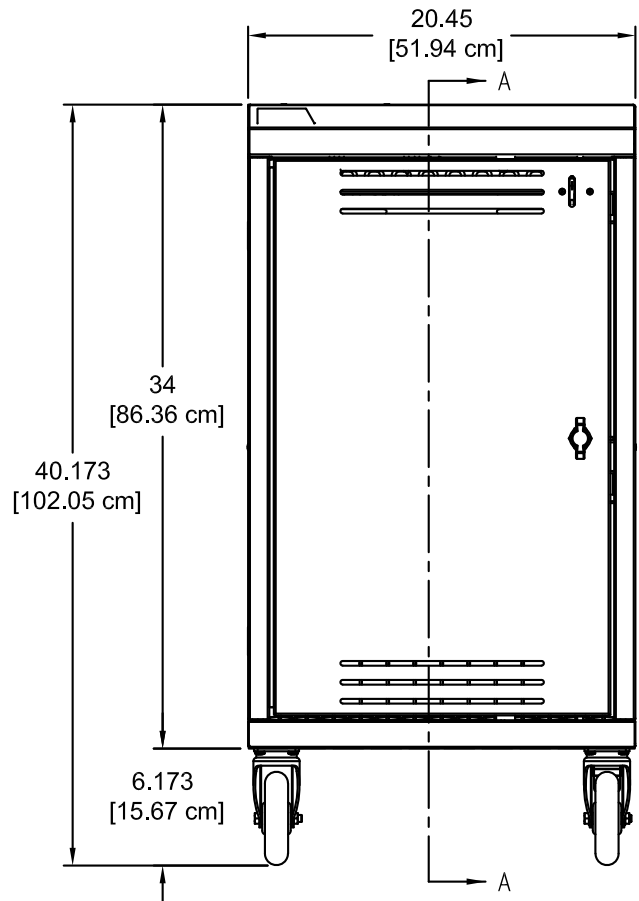
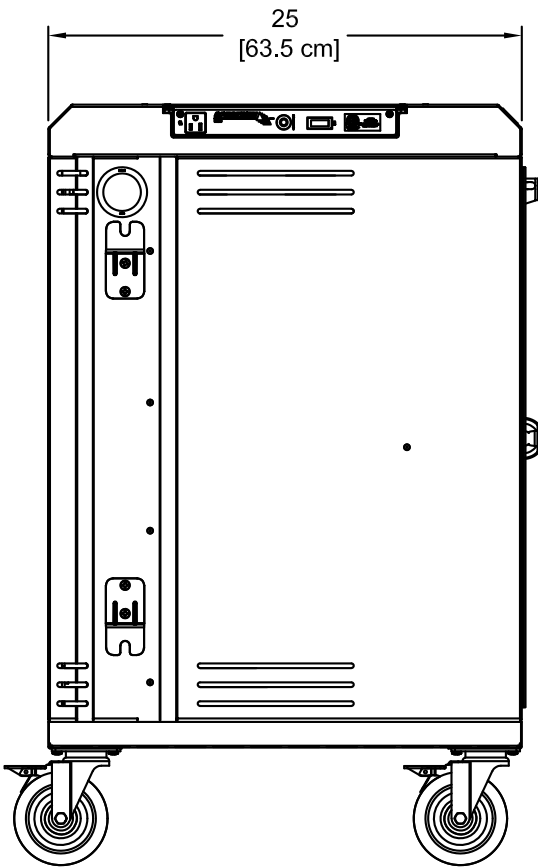
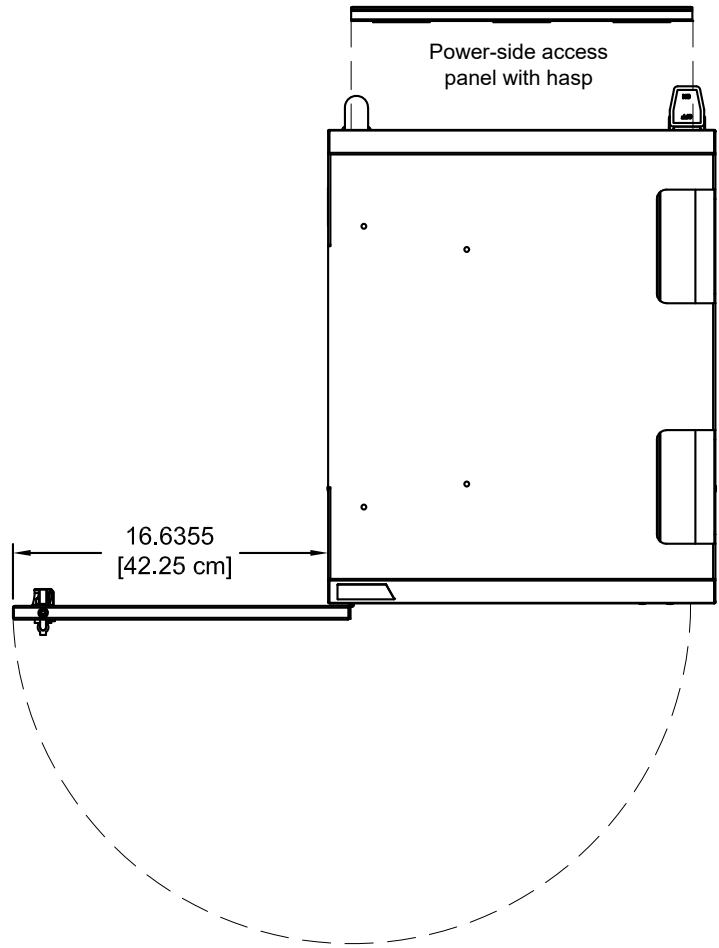
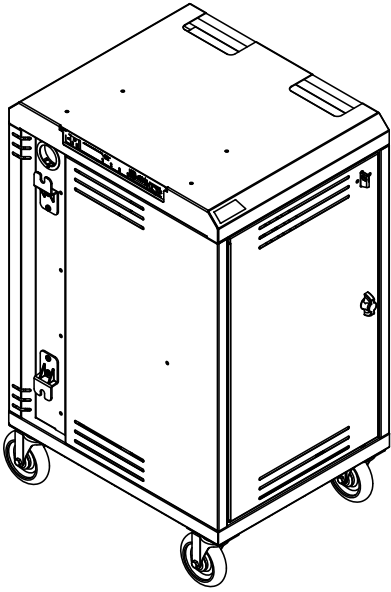

Connect24
Section view A-A

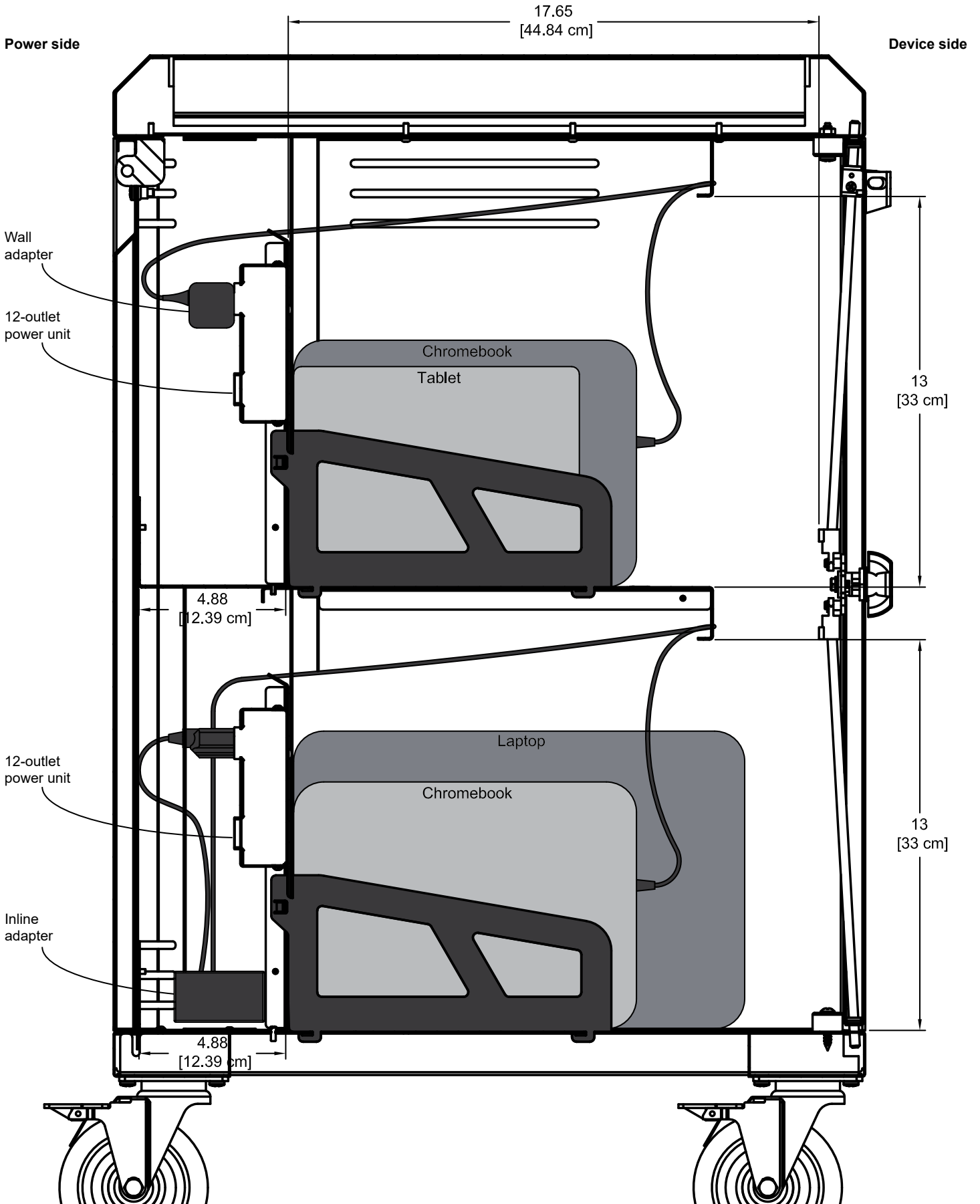

Connect24
Device side view wiring diagram
(shown without door)

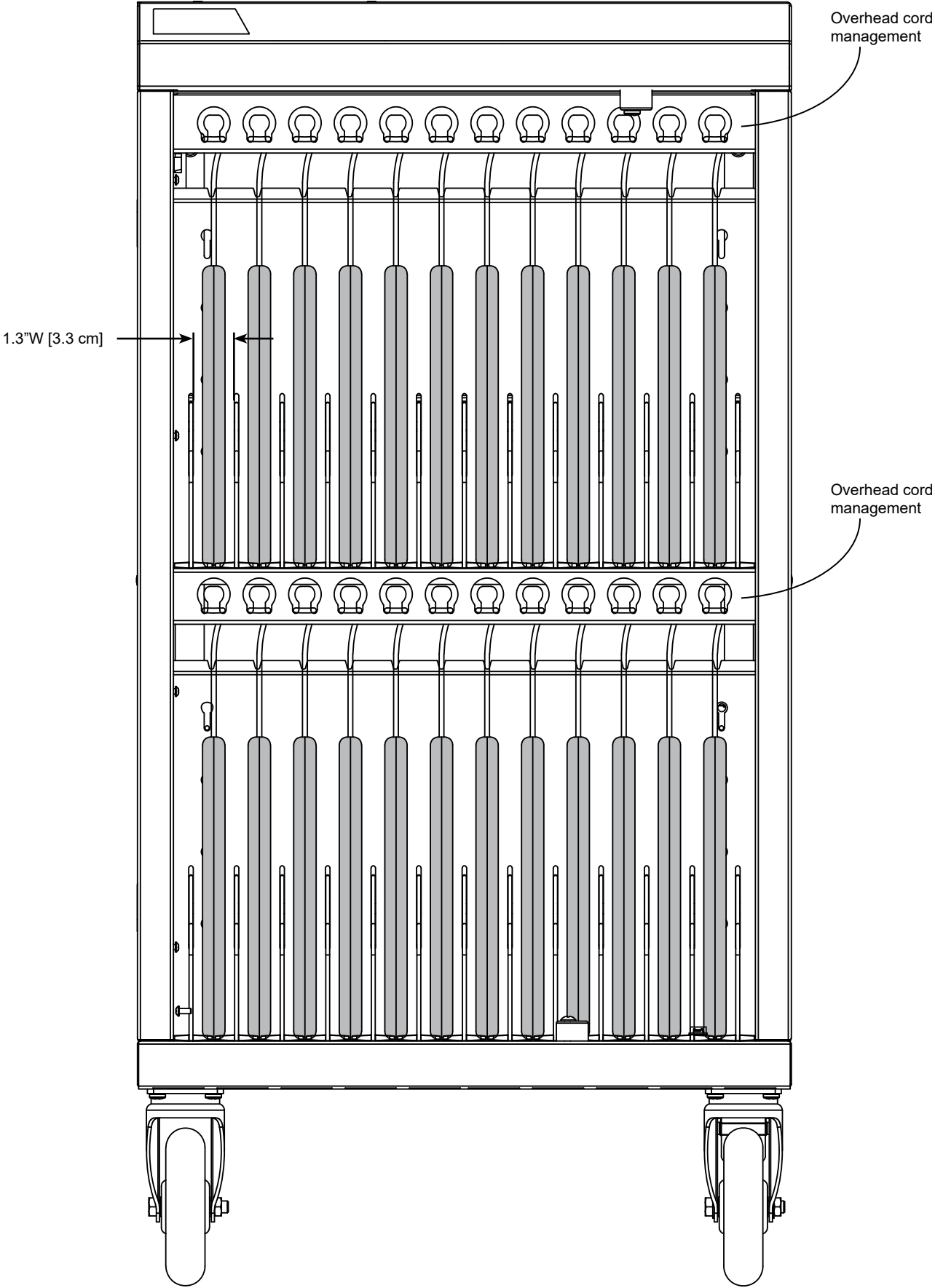

Connect24
Power side wiring diagram
(shown with standard outlets, and locking panel removed)

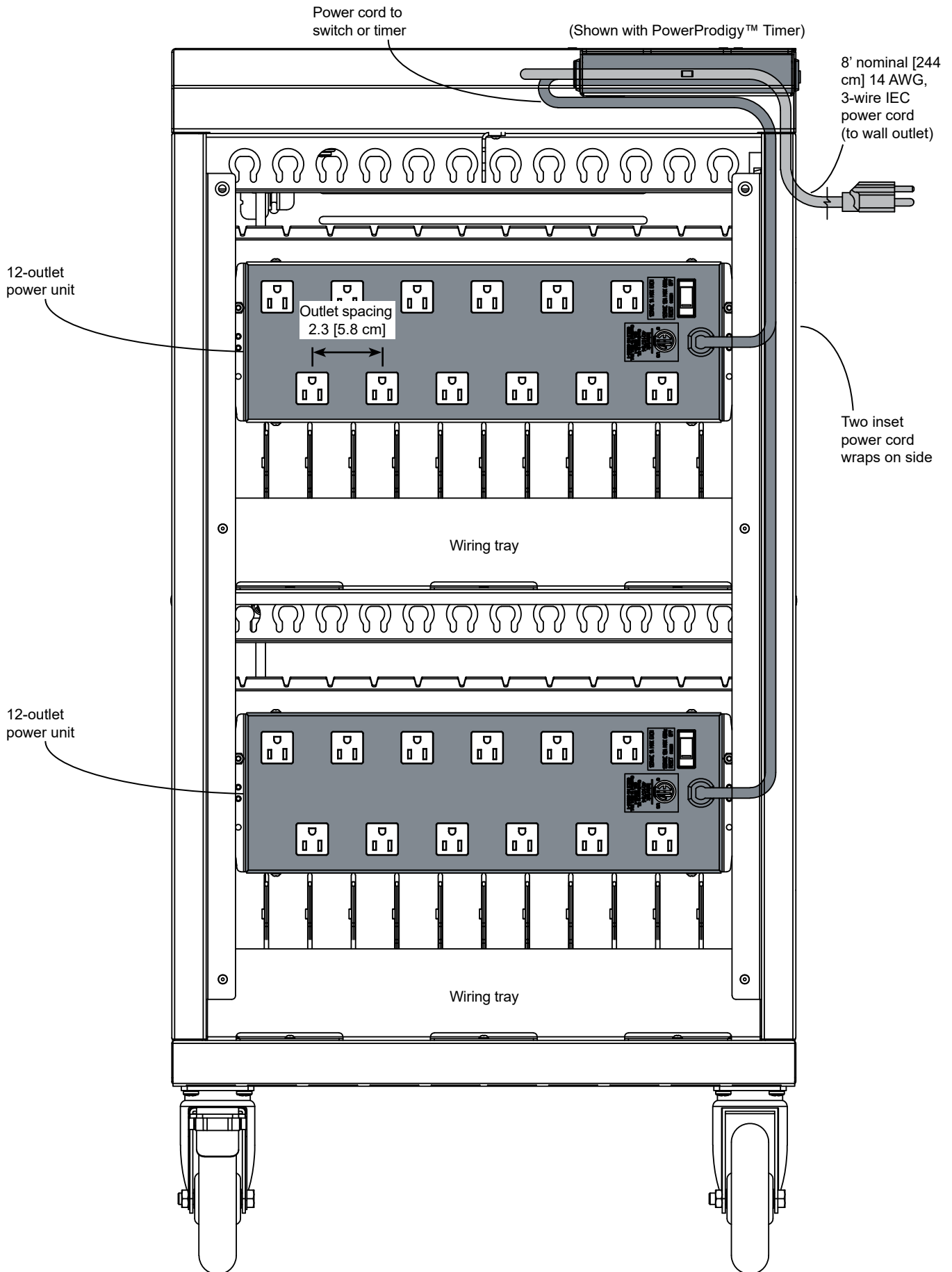

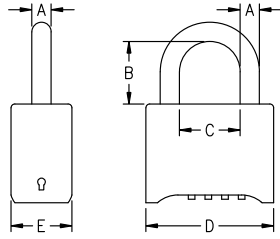

A	.3125" [7.9 mm]
B	1" [25.4 mm]
C	.983" [25 mm]
D	2.07" [52.5 mm]
E	.987" [25.1 mm]



Re-programmable 4-digit Combination Lock - 95536

- Set your own 4-digit personalized combination (up to 10,000 options)
- 5/16" hardened steel shackle for cut-resistance
- Black powdercoated die-cast body for durability
- Change key included
- Unit weight: .55 lb [.25 kg]

Hook-and-loop Strap Kit - 95004

(16) .75" [1.91 cm] x 12" [30.48 cm],
and (32) .75" [1.91 cm] x 5" [12.7 cm]

Warranty

We will make it right for you!

Thanks for choosing Spectrum! Spectrum is committed to provide complete customer satisfaction. Each of our products is manufactured from the best materials available and each product is stringently monitored throughout the production process through our P.A.C.E. program (Product Assurance to meet Customer Expectations).

We expressly warrant that Spectrum products will be of good quality and workmanship and free from defect for the period set out in the warranty from the date of delivery.

For a listing of all product specific warranty terms please visit our website at:

<https://www.spectrumfurniture.com/en/resources/purchasing-terms-warranty>

1-800-235-1262

Toll-free HELPLINE

spectrum@spectrumfurniture.com