

Assembly Instructions

⚠ Important ⚠

Before you begin, read and comply with all safety and operating instructions, and ensure all parts and correct quantities are included.

Any parts damaged during shipment must be reported within 5 days of receipt. To report information regarding missing parts or damage, to purchase parts or accessories, or if you have any questions, please contact us.

www.spectrumfurniture.com
800-235-1262, 715-723-6750

Thank you for purchasing Spectrum products!

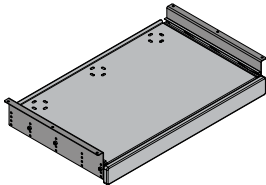

(1) 0118082
Keyboard Tray

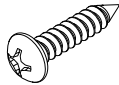

(6) 026073
#8 x 3/4" PHSM

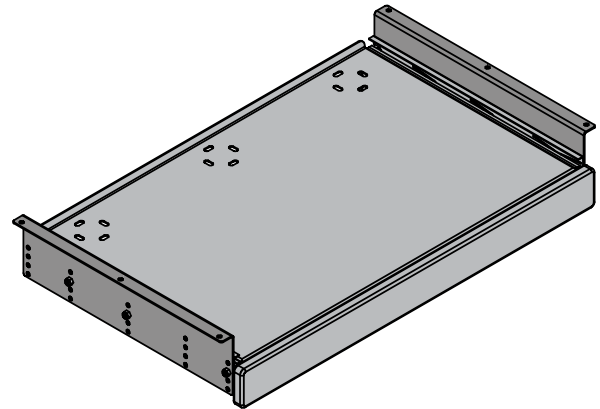

Keyboard Tray
#55379

1. Installation

1. Align the keyboard tray assembly with the (6) pre-drilled mounting holes under the worksurface. **Figure 1.** (2 people may be needed to install.)
2. Install (6) #8 x 3/4" PHSM screws to secure to the worksurface. Tighten securely. (If using an electric drill, be sure to use a low torque setting to avoid stripping the worksurface holes.)
3. Use the tray slots and zip ties or hook and loop straps (not included) to secure cords.

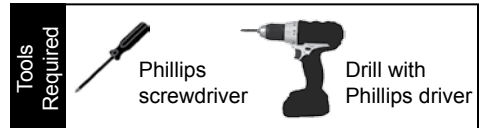

2. Tray / Drawer

Note: The dual-use tray can be used as a keyboard tray, or easily flipped and used as a drawer.

1. To flip, pull out the tray and locate the black plastic lever on each slide.
2. Release the levers (left-down, right-up) while pulling the tray out of the slides.
3. Flip the tray, re-align the slides, and push back in.

3. Height adjustment (optional)

1. The tray height can be adjusted by repositioning the slides using 8-32 screws, locknuts, and height-adjustment holes. **Figure 2.**
2. To adjust the height, remove the (3) 8-32 screws and locknuts (with 11/32" wrench) from each side. (Slide the tray to access each screw).
3. At the new height, replace the screws and locknuts and tighten securely.

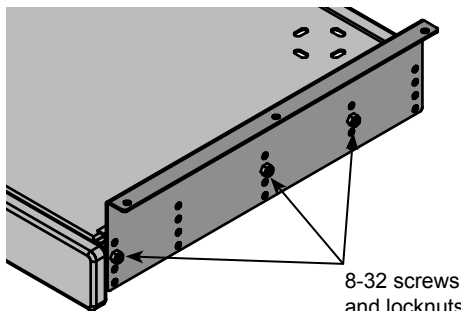

8-32 screws
and locknuts

Figure 2

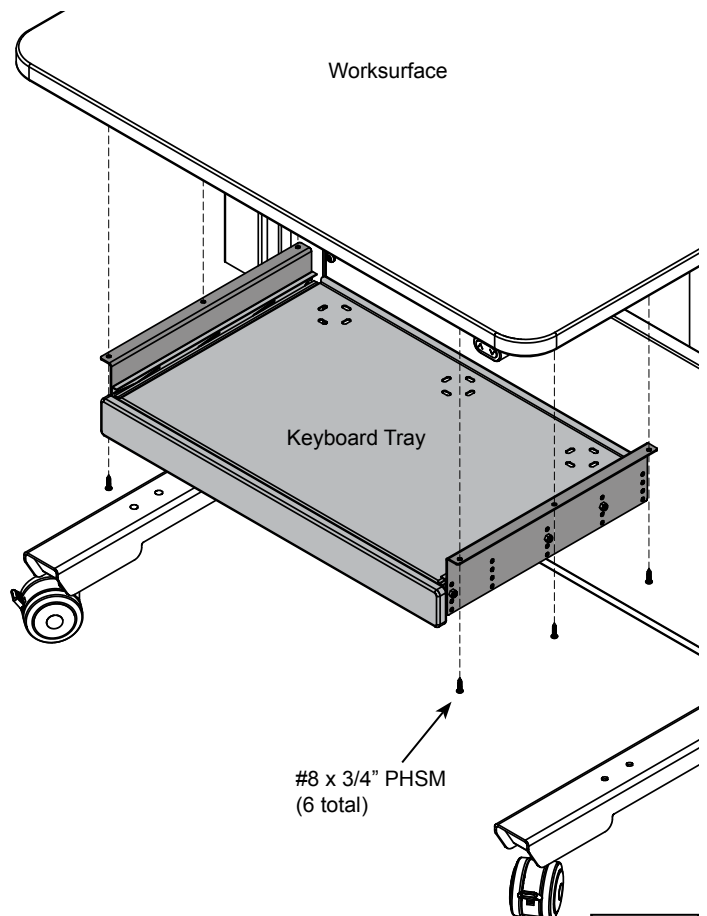

#8 x 3/4" PHSM
(6 total)

Figure 1