

Technical Specifications

55559

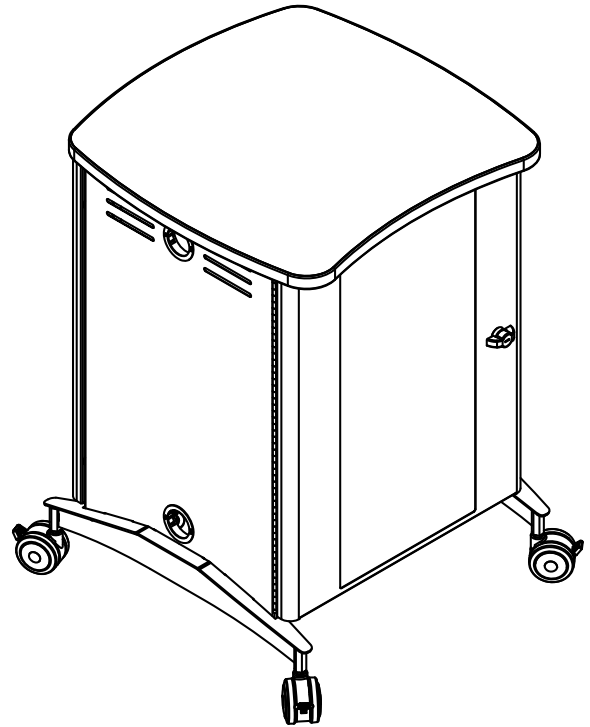
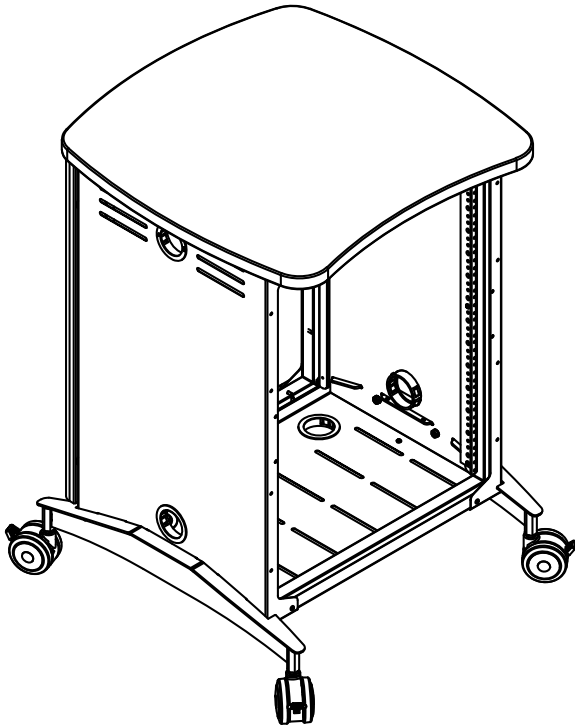

Shown with optional instructor-side door

Take your AV with you with the Companion Equipment Rack. This portable AV solution was designed to pair perfectly with the Pivot Premier workstation (or used by itself) and can go where you go. It provides 14RU for the instructor-side and can be doubled by adding the optional Rear Rack Rail Kit (68100). Add the Acrylic Instructor-Side Door for additional security for your equipment.

Features and Benefits

- Freestanding rack provides 14RU on instructor-side
- The optional Rear Rack Rail Kit (68100) provides an additional 14RU
- Locking casters provide mobility
- Standard audience-side door with matching laminate insert panel makes rear AV access simple
- Optional Acrylic instructor-side door (55560) provides additional security for expensive equipment
- 2" side grommets provide easy cord routing
- Ventilated side and bottom panels keep equipment cool
- Warranted to be free of all defects in materials and workmanship for 10 years
- Designed and assembled in Chippewa Falls, WI, USA

Color Options

Available in Spectrum Expressions colors.
See spectrumfurniture.com for complete color information.

Ordering Instructions

Spectrum has designed this product to receive the useful options shown here.
To ensure your options are ordered correctly please call 1-800-235-1262.

Construction

- The worksurface is constructed from 1" thick composite board with .030" high-pressure laminate on one face, and a balancing phenolic backer on the opposing face
- Leg components consist of 7-gauge steel
- Worksurface edges are covered with 3mm vinyl
- All metal components are finished with a scratch-resistant powder coat epoxy
- Each Companion Equipment Rack is shipped KD (Knocked-Down) and requires assembly

Specifications

Overall Dimensions:	24"W [61 cm] x 24"D [61 cm] x 33.9"H [86.1 cm]
Rack Units:	14RU
Rack Unit depth:	16" (without optional rear rack rails)
Twin-wheel casters	<ul style="list-style-type: none"> • Diameter: 3" • Locking: all 4 casters • Weight capacity: 165 lb [75 kg] each
Certifications / Compliance	Meets or exceeds applicable ANSI-BIFMA test standards
Unit weight:	64.4 lb [29.2 kg]
Shipping weight:	94.4 lb [42.9 kg]

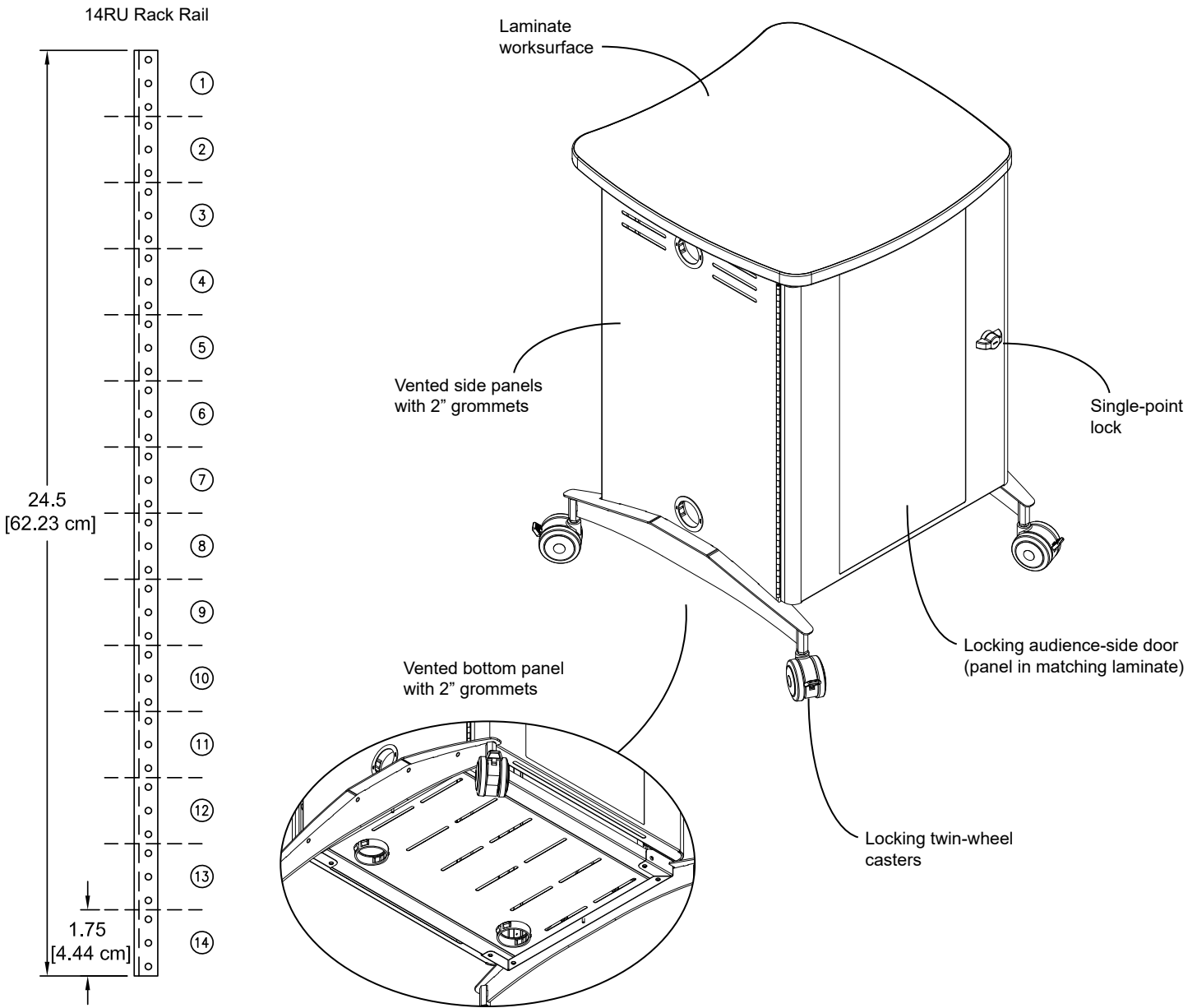

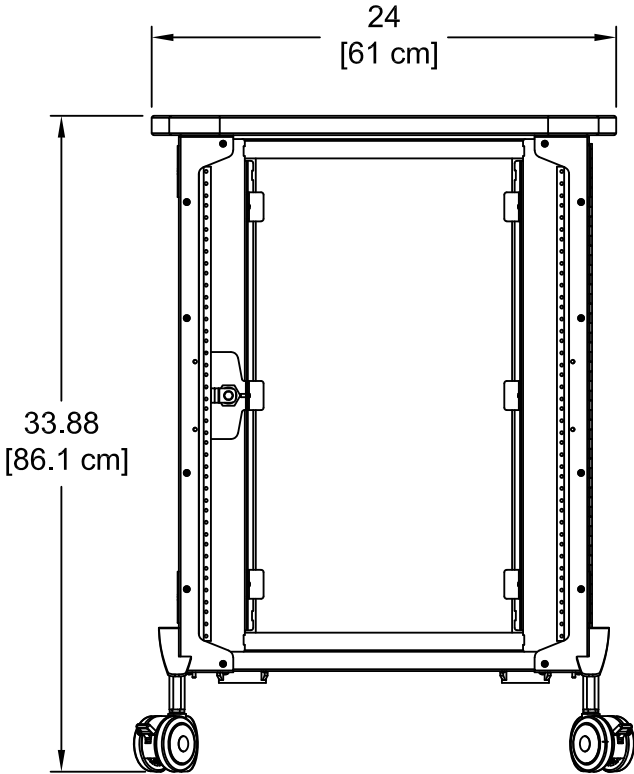
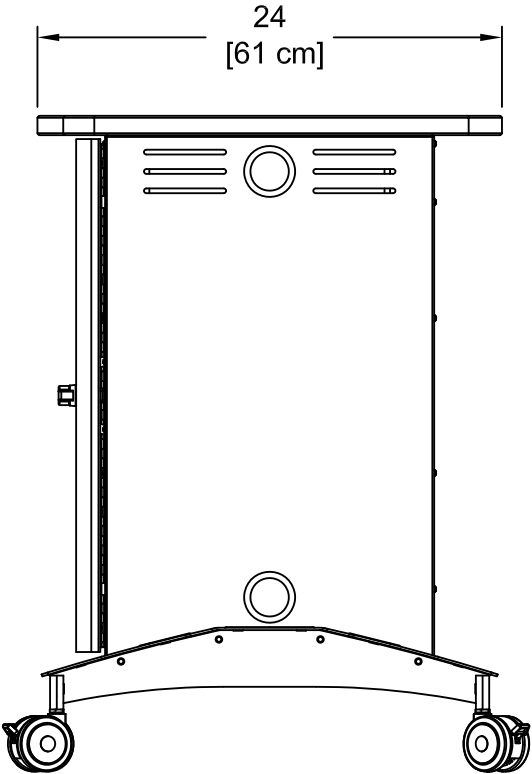
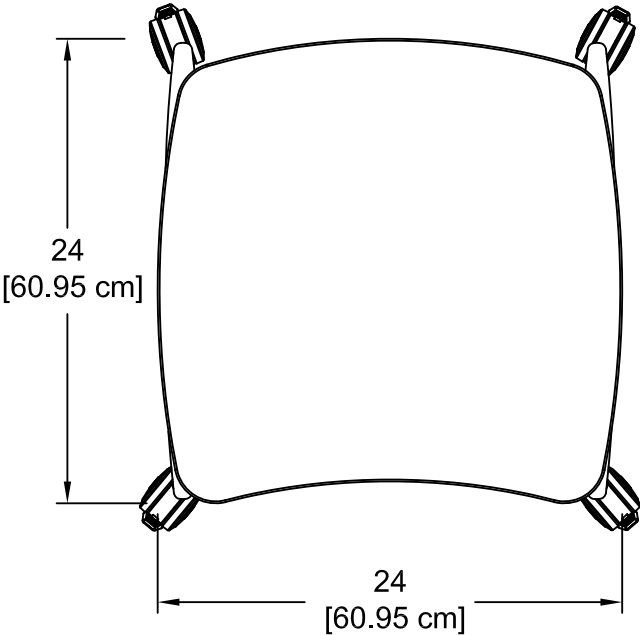
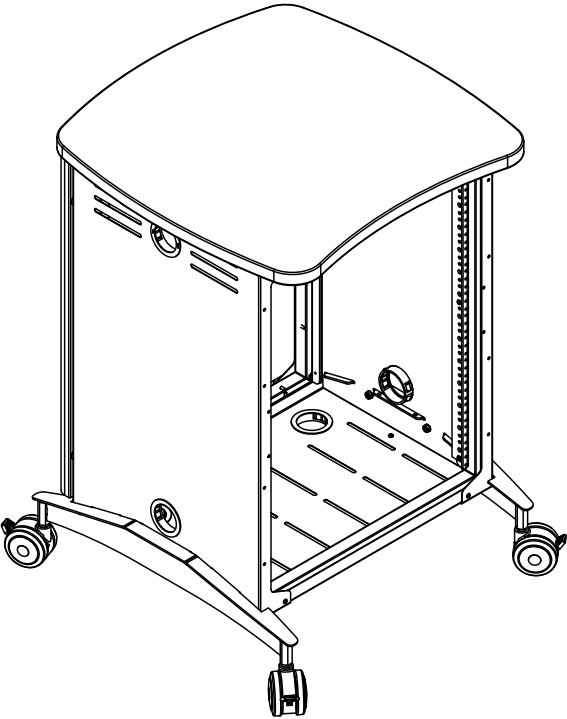

Companion Equipment Rack
Section view A-A

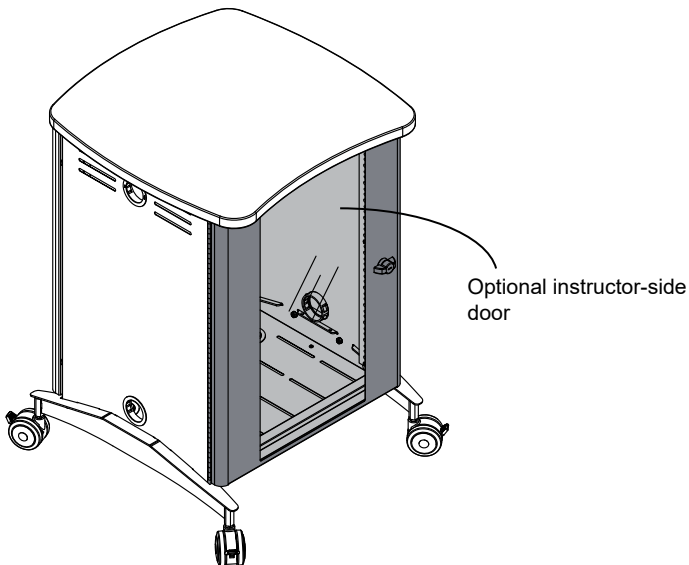
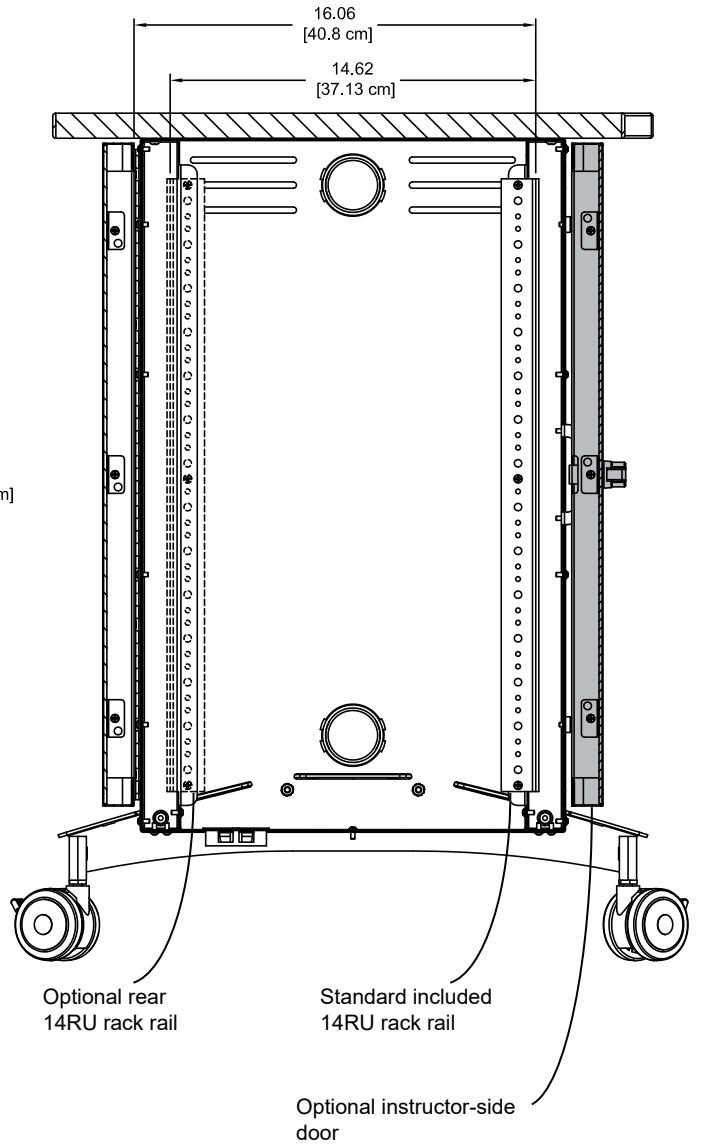
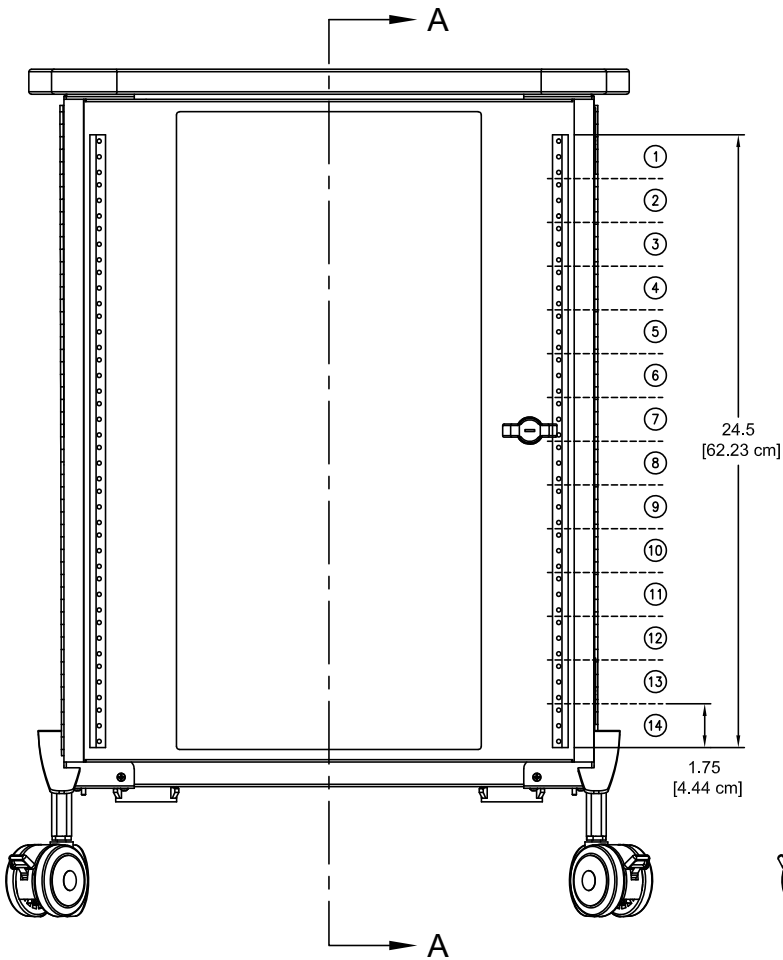

Accessories

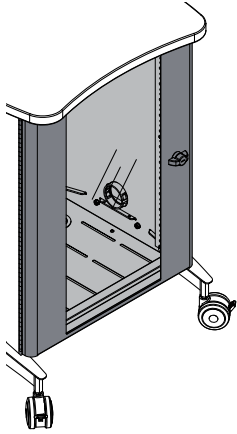

Acrylic Instructor-Side Door - 55560

- Installs on Companion Equipment Rack
- Single-point lock provides security
- Acrylic panel provides ability to monitor internal components
- Door can be installed to be hinged from the left or right
- Ventilation slots on top and bottom edges
- Customer-installed
- Shipping weight: 10 lb [4.5 kg]



Rear Rack Rail Kit - 68100

- Adds 14RU to student-side of Companion Equipment Rack
- Set of 2
- Shipping weight: 3.2 lb [1.5 kg]

Rack-mount Accessories

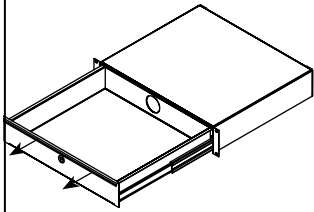

Locking Drawer - 2RU - 97527

- 16ga steel
- Drawer: 15.97"W [40.56 cm] x 14.56"D [36.98 cm] x 3"H [7.63 cm]
- Weight capacity: 50 lb [22.7 kg]
- Shipping weight: 15.85 lb [7.2 kg]

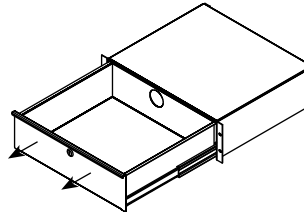

Locking Drawer - 3RU - 97526

- 16ga steel
- Drawer: 15.97"W [40.56 cm] x 14.56"D [36.98 cm] x 5.25"H [13.33 cm]
- Weight capacity: 50 lb [22.7 kg]
- Shipping weight: 18.5 lb [8.4 kg]

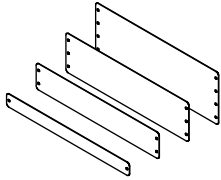

Rack-Mount Blanks

1RU - 97510 3RU - 97512
2RU - 97511 4RU - 97513

- Fills rack spaces where components are not needed
- 16 ga steel
- Shipping weight: <1 lb [0.45 kg]

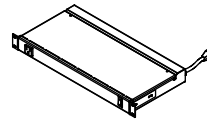

9-Outlet Power Strip - 1RU - 99021

- 8 outlets rear (breaker-protected)
- 1 convenience outlet front
- 115VAC, 60 Hz, 15 amps max
- 9' power cord
- Front LED power switch
- Enhanced surge protection
- ETL-listed, UL-listed
- 19"W [48.27 cm] x 9.25"D [23.5 cm] x 1.74"H [4.41 cm]
- Shipping weight: 8.7 lb [3.9 kg]

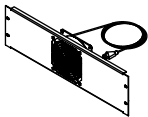

Single Fan - 3RU - 97507

- 50 cfm
- 120V~50/60 Hz, 15/13W
- RoHS
- 19"W [48.27 cm] x 1.56"D [3.97 cm] x 5.25"H [13.33 cm]
- Shipping weight: 3.78 lb [1.7 kg]

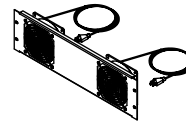

Double Fan - 3RU - 97506

- 100 cfm
- 120V~50/60 Hz, 15/13W
- RoHS
- 19"W [48.27 cm] x 1.56"D [3.97 cm] x 5.25"H [13.33 cm]
- Shipping weight: 5.47 lb [2.5 kg]

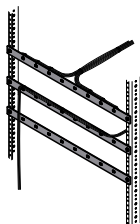

Wire Lace Kit - 95517

- Provides wire management
- Mounts to standard rack rails
- Includes (3) lace straps and mounting screws
- Includes (12) 5.5" zip ties
- Shipping weight: 1.25 lb [0.57 kg]

See spectrumfurniture.com for the latest accessories and detailed warranty information.

Warranty

We will make it right for you!

Thanks for choosing Spectrum! Spectrum is committed to provide complete customer satisfaction. Each of our products is manufactured from the best materials available and each product is stringently monitored throughout the production process through our P.A.C.E. program (Product Assurance to meet Customer Expectations).

We expressly warrant that Spectrum products will be of good quality and workmanship and free from defect for the period set out in the warranty from the date of delivery.

For a listing of all product specific warranty terms please visit our website at:

<https://www.spectrumfurniture.com/en/resources/purchasing-terms-warranty>

1-800-235-1262

Toll-free HELPLINE

spectrum@spectrumfurniture.com