

## Technical Specifications

	Product #
60"W - Single Station	37420
76"W - Double Station	37419

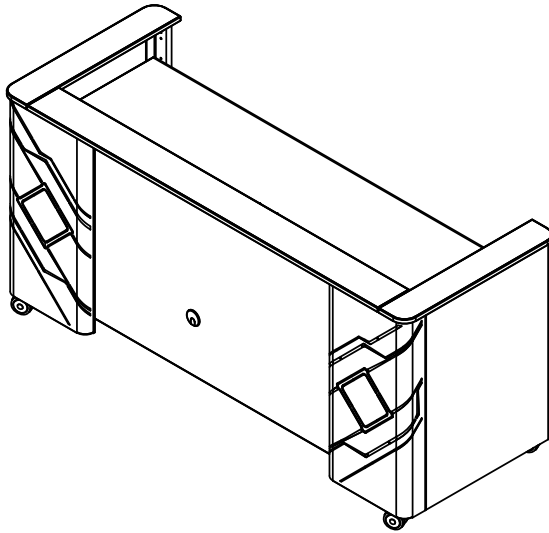

76"W Double Station - 37419

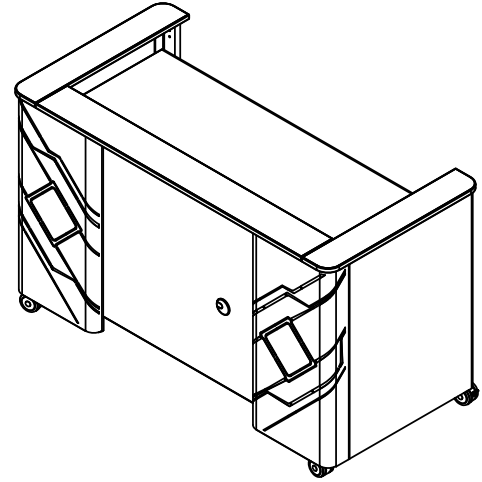

60"W Single Station - 37420

The Esports Shoutcaster Station is the ultimate command center for gaming competitions! Ample configurations provide the ideal media station to capture the attention of your audience. Multiple monitor mounting options are available including monitor arms, worksurface mount, or audience-facing to customize your station for optimal performance. The Esports Shoutcaster Station is available in two sizes and has ample space for mixers, keyboards, stream decks or whatever technology it takes to stay on top of the game. Couple that with exciting color options and smooth movement casters, and you can take the strength and energy of your team anywhere! With "Made In The USA" quality built in Chippewa Falls, WI; Spectrum Esports Shoutcaster / Broadcast Station offers effective ergonomics, ADA compliance, and a wide array of useful accessories!



Spectrum also has the capability to outfit your campus esports furniture in our Expressions colors to promote your team identity! Want a custom or team logo on your classroom esports furniture? We can do that too. No matter your budget or requirements, Spectrum has your Esports furniture solution.

## Features and Benefits

- Available in 60" and 76" wide versions
- Accommodates multiple display mounting options
- The worksurface can be adjusted between 27-30"H (during assembly)
- Twin wheel casters for easy mobility (2 locking, 2 non-locking)
- Scratch and impact-resistant high-pressure laminate worksurface
- Grommets throughout unit provide easy cord access
- Pre-drilled monitor mounting holes
- User-friendly, bullnose radiused front edge on worksurface
- Black and Steel Mesh laminates minimize glare and player distraction
- Color accents match chairs and arena / team branding
- Optional VESA mount provides flat panel monitor mounting on worksurface
- Optional monitor mount provides ability to install a large monitor on audience-side (76"W only).
- Optional audience-side logo panel is easily swappable for different teams or competitions
- Optional tray or sling provides CPU tower storage under worksurface
- Optional LED lighting kit provides custom backlighting options for corner columns
- Unit ships "knocked-down" for lower shipping costs and can be easily assembled at the final location
- Warranted to be free of all defects in materials and workmanship for 10 years
- Designed and assembled in Chippewa Falls, WI, USA

### Color Options

See p.3 and [spectrumfurniture.com](http://spectrumfurniture.com) for complete color information.

### Ordering Instructions

Spectrum has designed this product to receive the useful options shown here. To ensure your options are ordered correctly please call 1-800-235-1262.

## Construction

- The worksurfaces are constructed from 1" thick NAF (no added formaldehyde) composite board with .030" [.762mm] high-pressure laminate on one face, and a balancing backer on the opposing face
- Worksurface edges are covered with vinyl edgeband
- All metal components are finished with a scratch-resistant powder coat epoxy
- All units are shipped knocked-down (KD) in 3 boxes and require assembly

## Specifications

Worksurface heights (set during assembly)	30"H [76.25 cm] 29"H [73.7 cm] 28"H [71.16 cm] 27"H [68.63 cm]	(3" of adjustability in 1" increments)
Cord channel dimensions	See p.7	
Twin-wheel casters	<ul style="list-style-type: none"> <li>• Diameter: 2.88" [7.31 cm]</li> <li>• 2 locking on student-side, 2 non-locking on audience-side</li> <li>• Weight capacity: 165 lb [74.9 kg] each</li> </ul>	
ADA-compliance*		(1) ADA seat per table ( <i>with or without CPU slings or trays</i> ) <i>*Minimum ADA guidelines for knee clearances are 30"W x 19"D x 27"H</i>
Certifications / Compliance	Meets or exceeds applicable ANSI-BIFMA test standards	
Shipping	3 boxes	
Unit weight (nominal)	185 lb [84 kg] - 60"W Shoutcaster - 37420 227 lb [103 kg] - 76"W Shoutcaster - 37419	
Shipping weight (nominal)	200 lb [91 kg] - 60"W Shoutcaster - 37420 257 lb [117 kg] - 76"W Shoutcaster - 37419	

Specifications subject to change without notice

### Twin-wheel casters

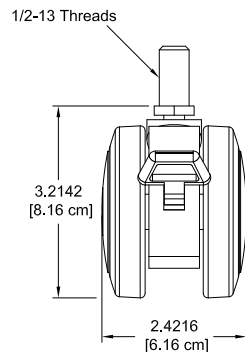
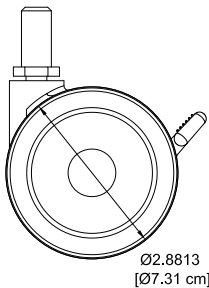
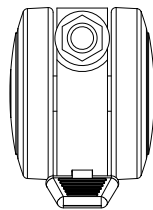
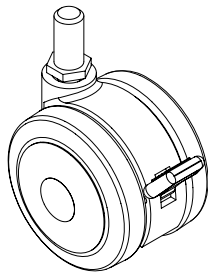

### Worksurface edge

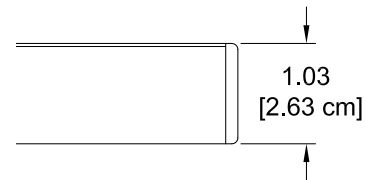

# Color options

\*See [Spectrumfurniture.com](http://Spectrumfurniture.com) for color examples

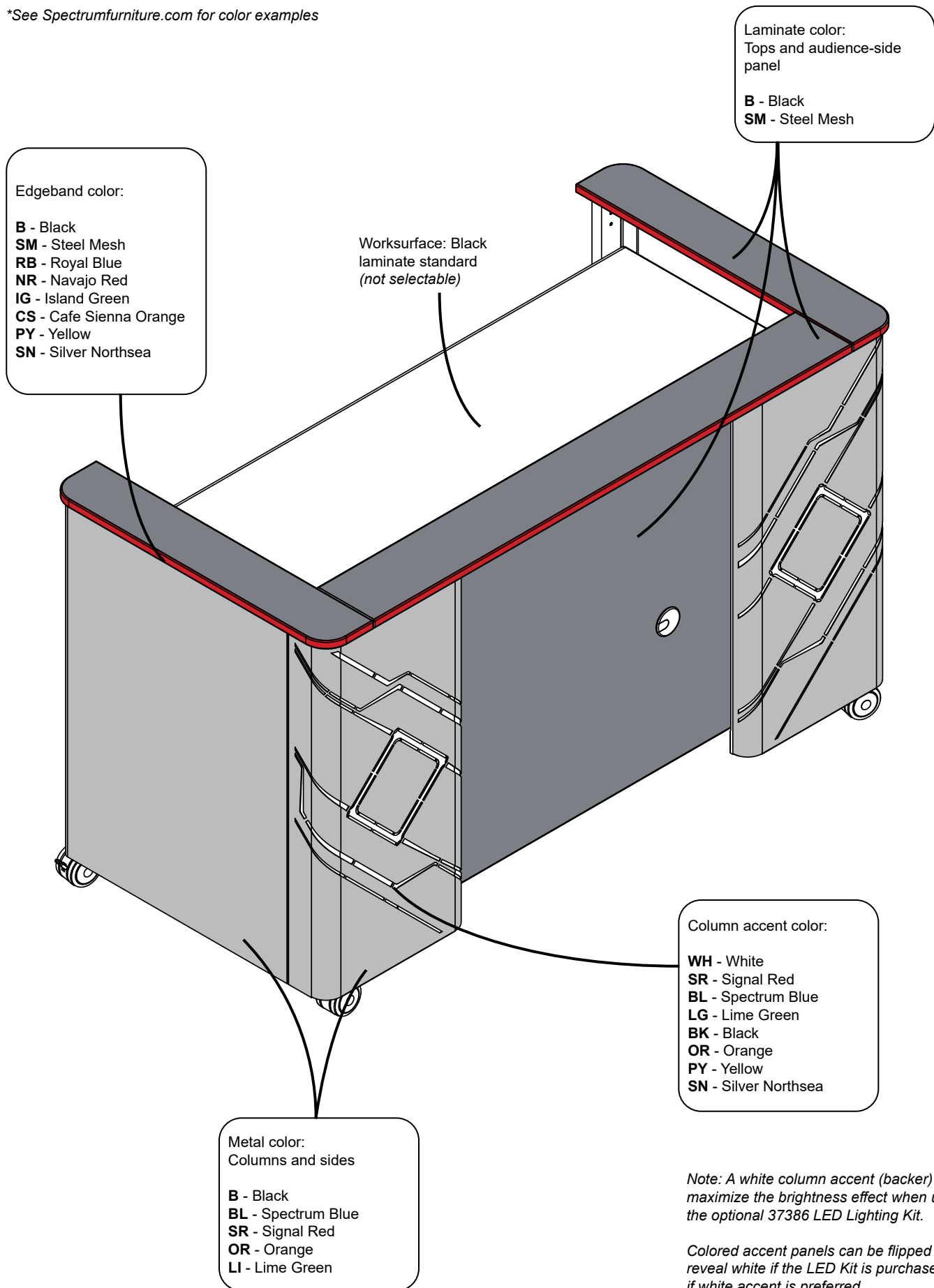

*Note: A white column accent (backer) will maximize the brightness effect when used with the optional 37386 LED Lighting Kit.*

*Colored accent panels can be flipped over to reveal white if the LED Kit is purchased later or if white accent is preferred.*

# 37420 - 60"W Single Station

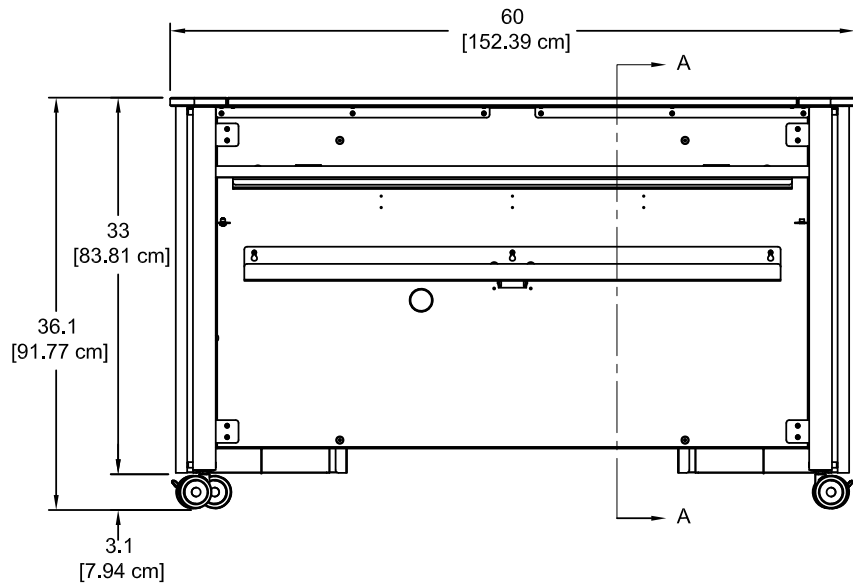
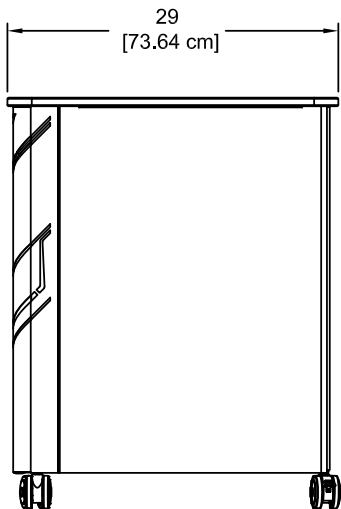
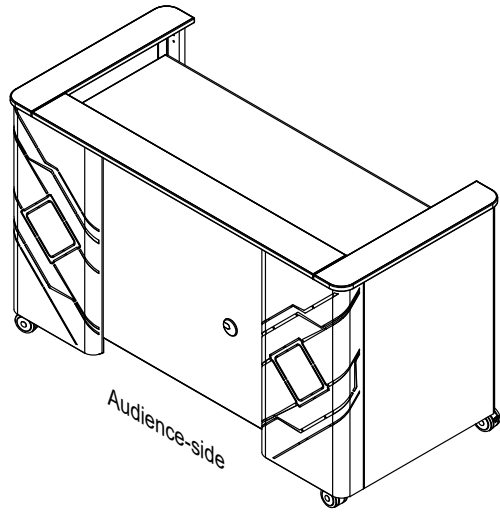
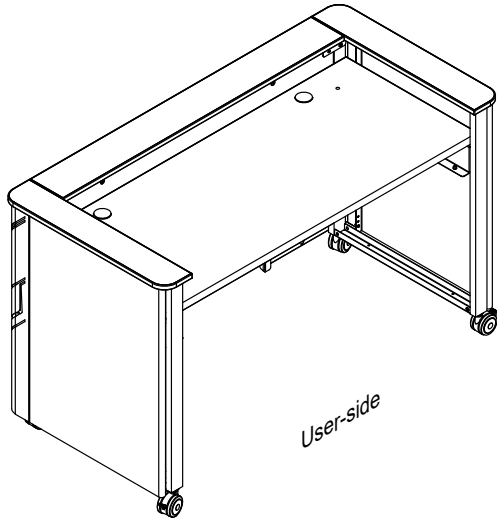

# 37419 - 76"W Double Station

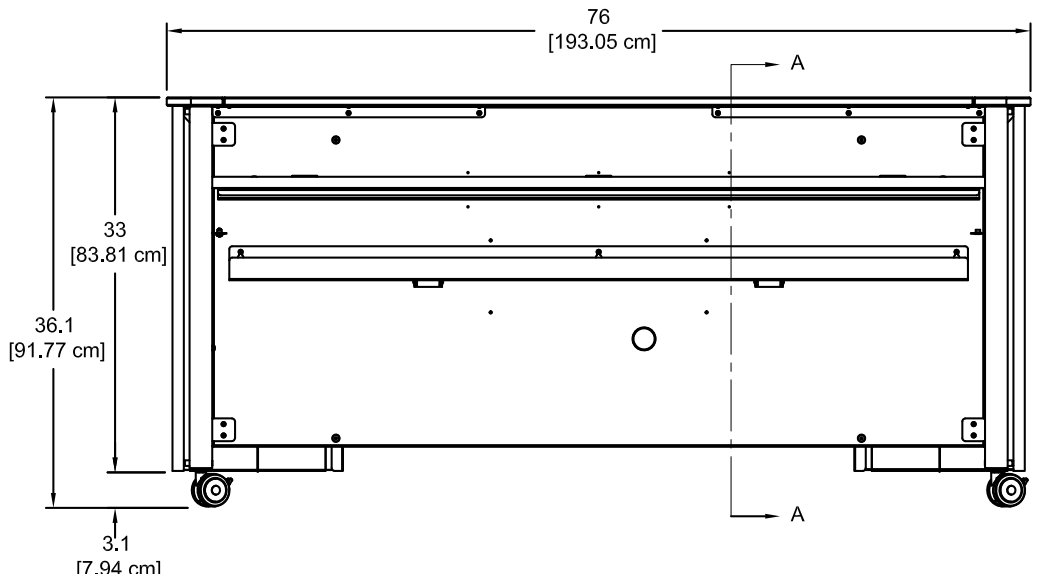
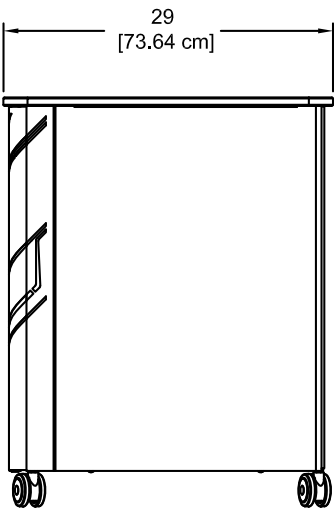
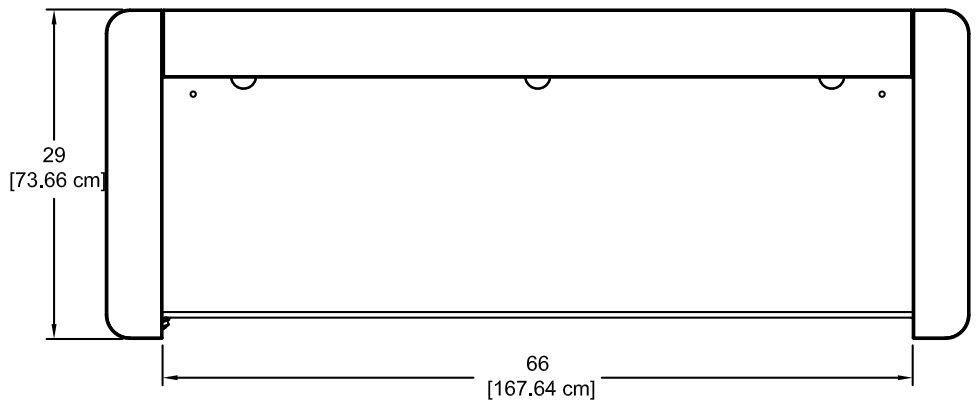
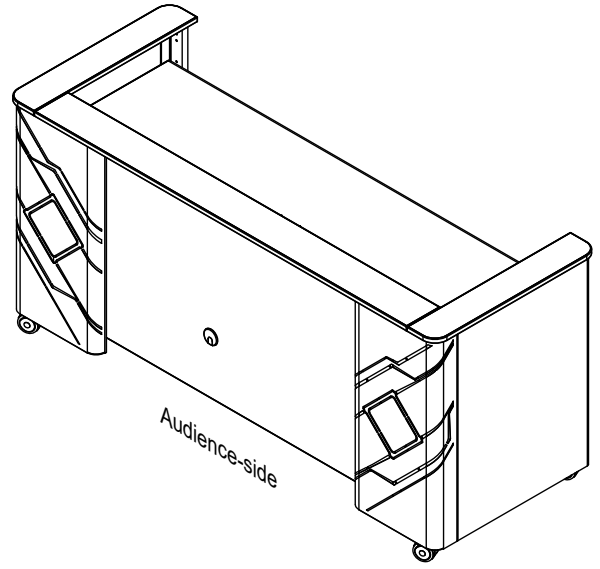
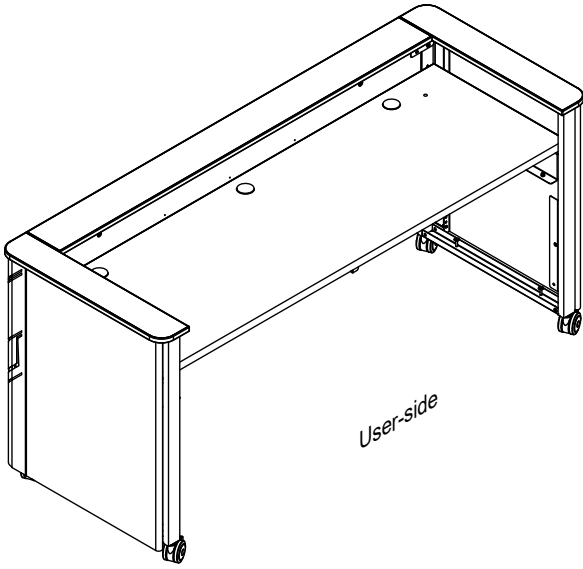

Audience-side

60"W Single Station - 37420

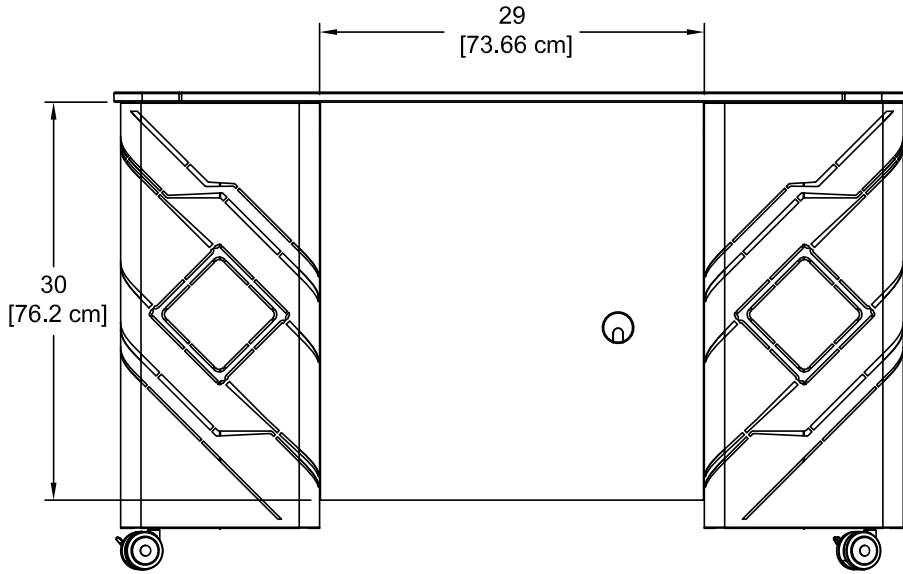

Using the optional **37388 - Swivel VESA Monitor Mount** accommodates most monitors up to 32" diagonal. (29" width available).

76"W Double Station - 37419

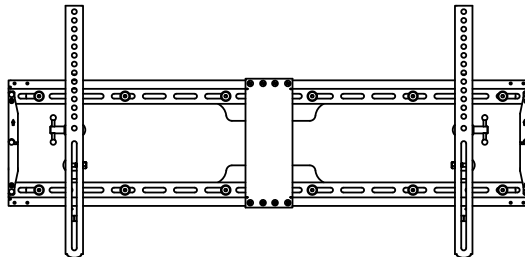
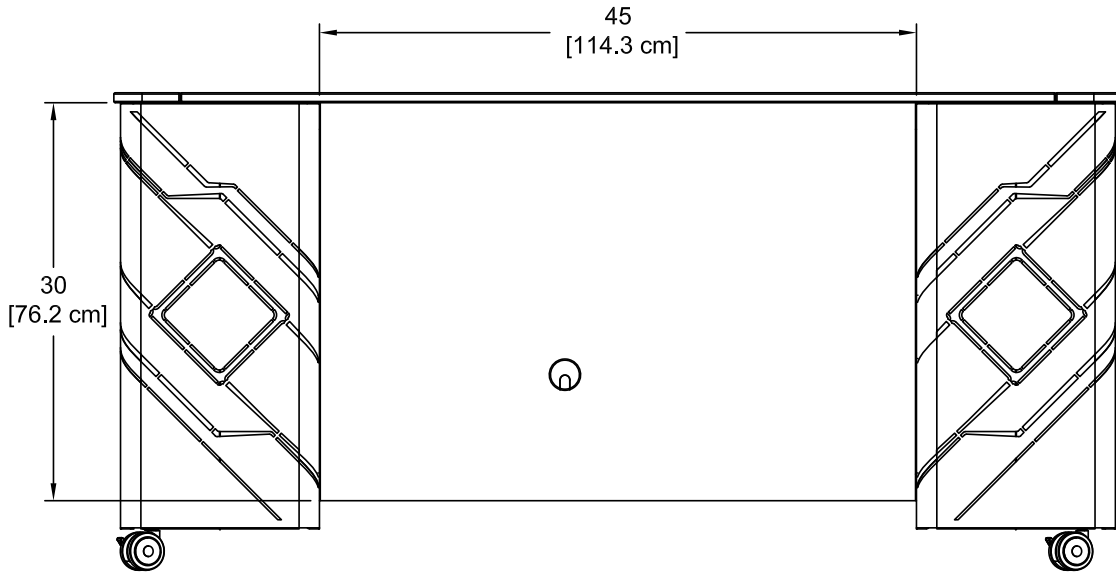

Using the optional **37387 - Monitor Mount** accommodates most monitors up to 50" diagonal. (45" width available).

Section view A-A

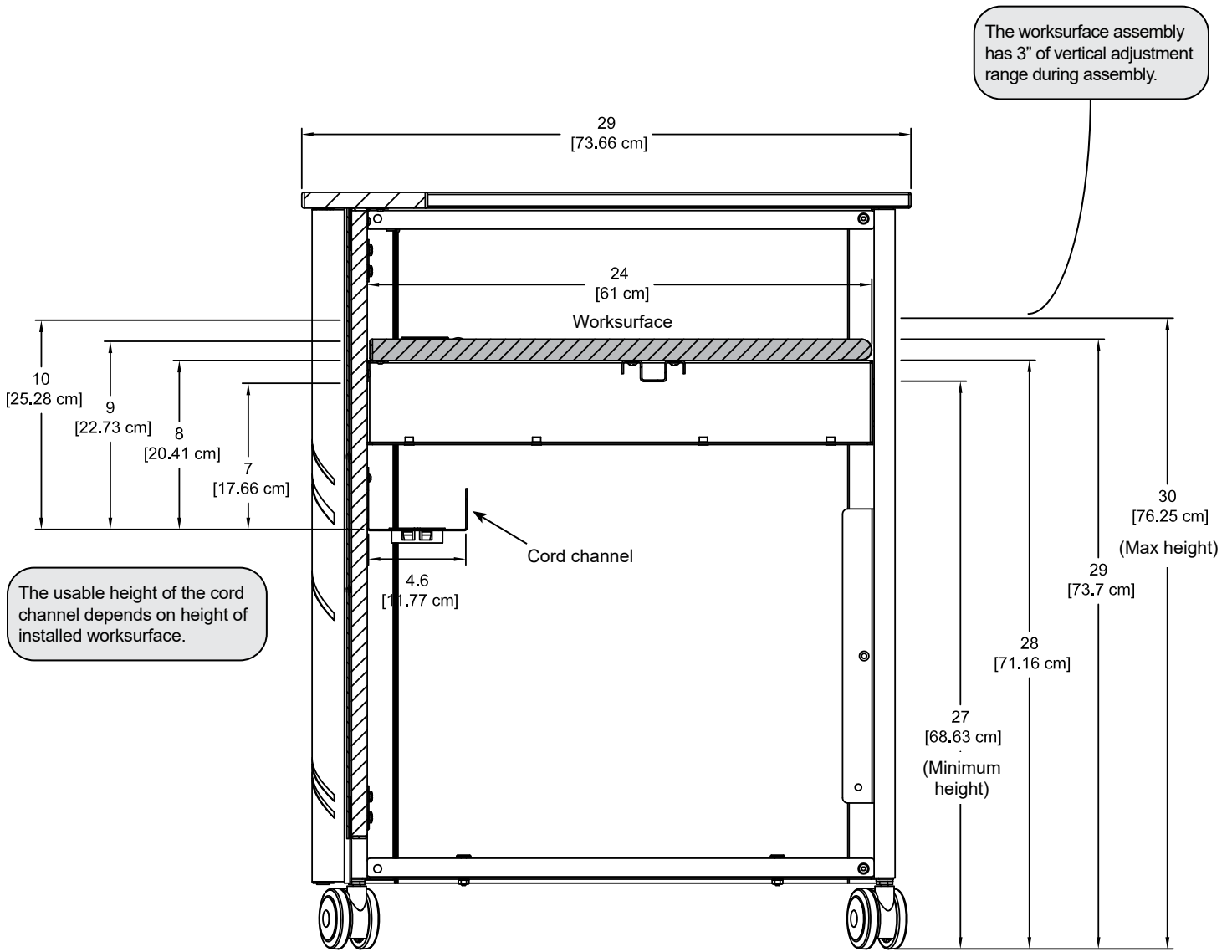

Optional VESA monitor mount spacing  
(Top views)

Provides display monitor mounting on  
worksurface (most monitors up to 24" diag)

60"W Single Station - 37420

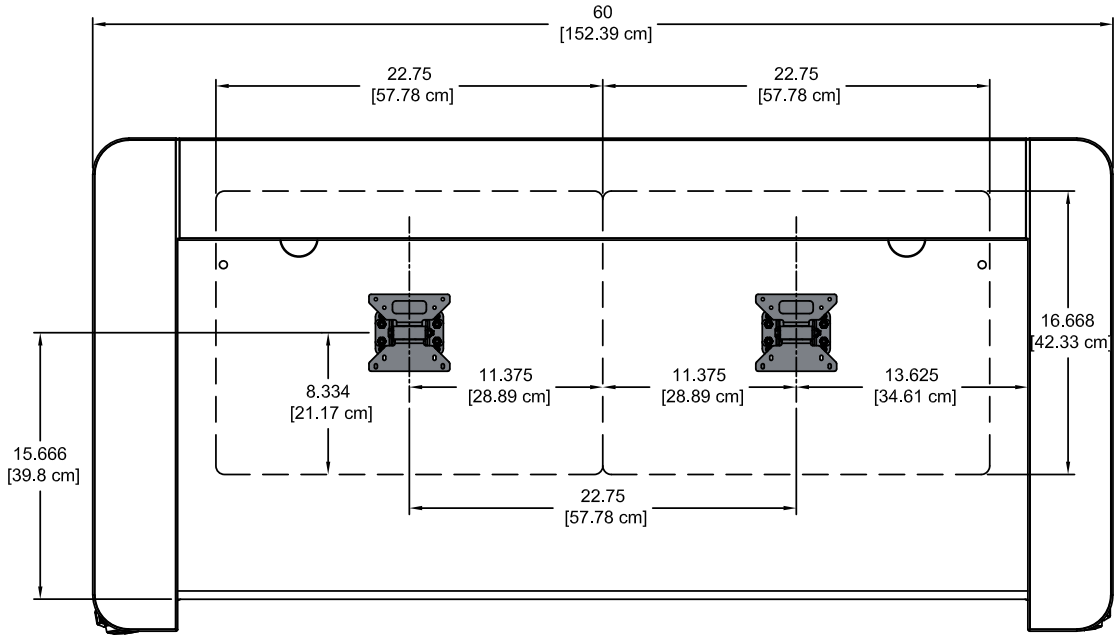

76" Double Station - 37419

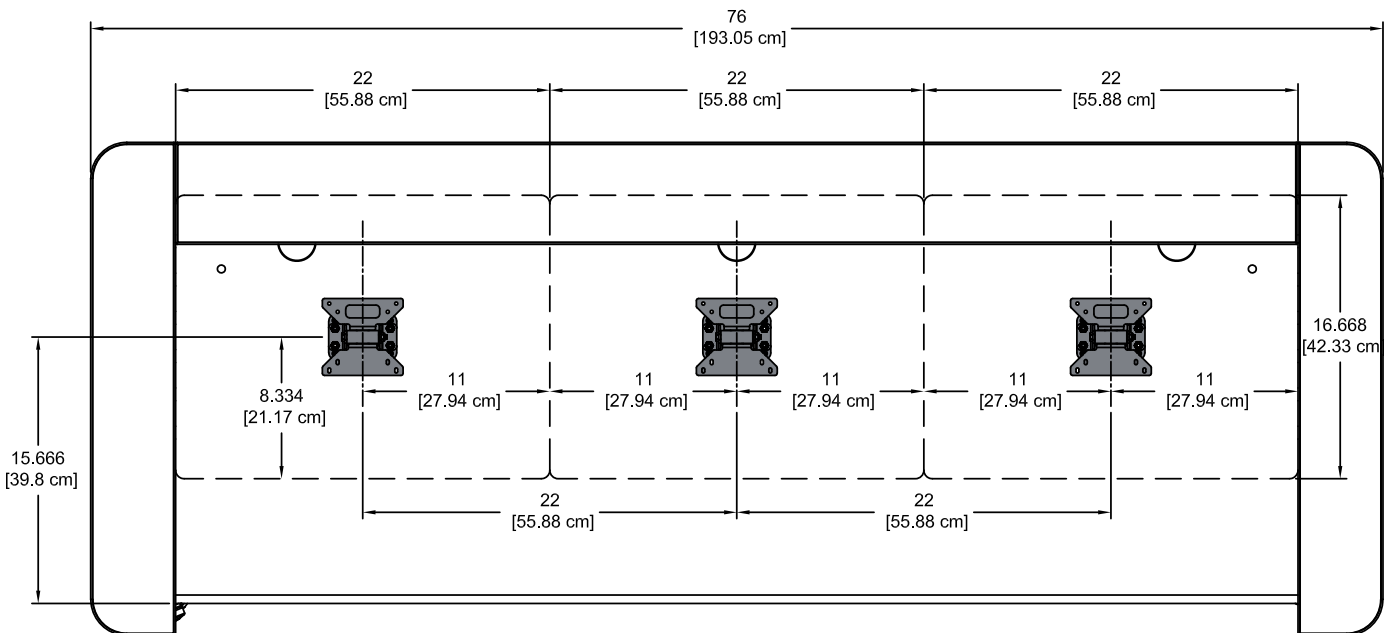



## Accessories

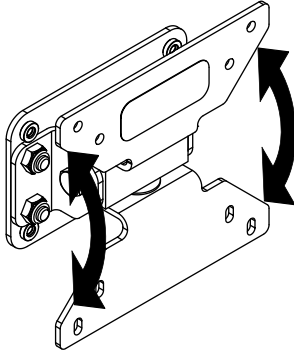

### Swivel VESA Monitor Mount - 37388

- Provides display monitor mounting on worksurface (most monitors up to 24" diag)
- Provides display monitor mounting on audience-side 60"W Shoutcaster - 37383 only (most monitors up to 32" diag)
- Internal travel stops-provide 4-direction tilt, 4° left, 4° right, 16° up, and 6° down (Specific monitor size, shape, and mounting location will determine exact angles of tilt)
- Works with 75mm and 100mm VESA mounts
- Includes mounting screws
- One mount included
- Unit weight: 1.19 lb [.54 kg]
- Shipping weight: 2 lb [.91 kg]

60"W Shoutcaster

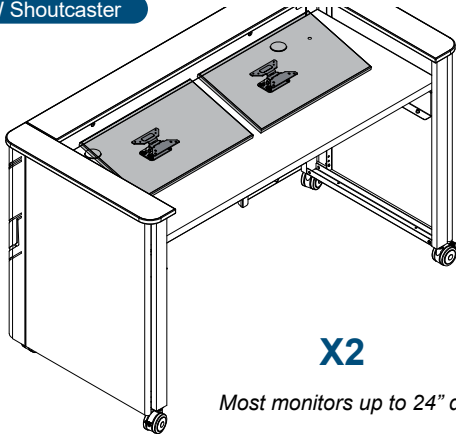

**X2**

Most monitors up to 24" diag

60"W Shoutcaster

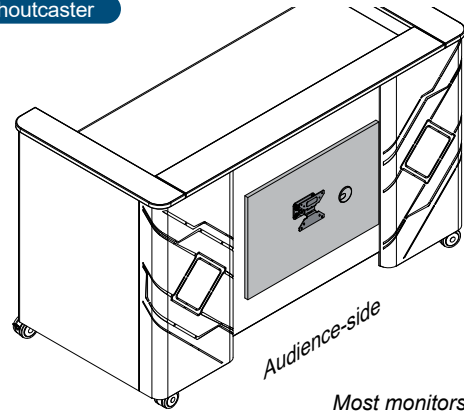

**X1**

Most monitors up to 32" diag

76"W Shoutcaster

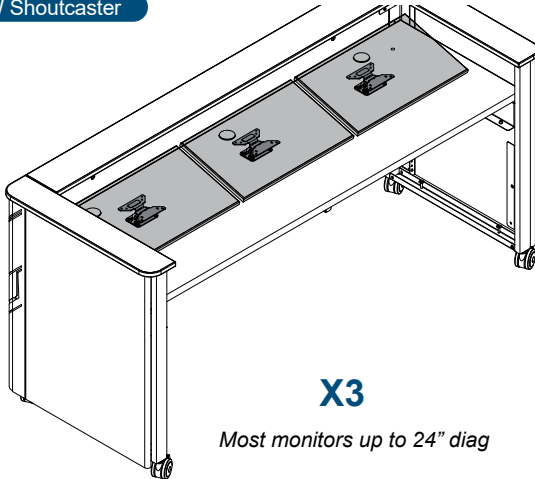

**X3**

Most monitors up to 24" diag

76"W Shoutcaster

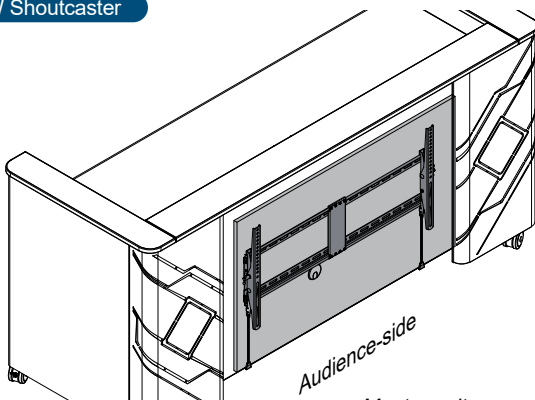

Most monitors up to 50" diag

### Monitor Mount - 37387

- Adjustable VESA-compatible display mount (for 76" Double Station - 37419 only)
- Provides display monitor mounting on audience-side (most monitors up to 50" diag)
- One mount included
- Unit weight: 8 lb [3.6 kg]
- Shipping weight: 9 lb [4.1 kg]

### 60"W Shoutcaster

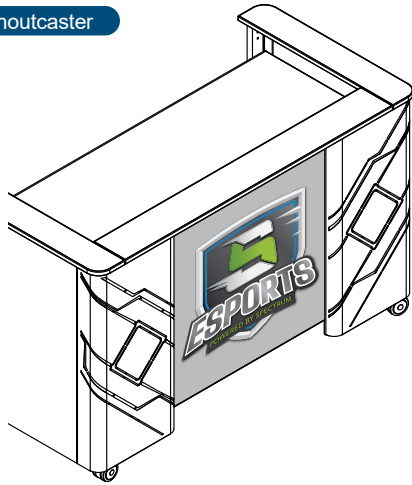

### Customized Logo Panel - Single - 37385

- Logo panel size: 29"W x 30"H
- Made of 3mm PVC sheet
- Easily attaches and removes with hook and loop fasteners
- New logos require a first time logo charge, to get panel customized-contact Spectrum for details
- Unit weight: 1.5 lb [.68 kg]
- Shipping weight: 2 lb [.91 kg]

### 76"W Shoutcaster



### Customized Logo Panel - Double - 37394

- Logo panel size: 45"W x 30"H
- Made of 3mm PVC sheet
- Easily attaches and removes with hook and loop fasteners
- New logos require a first time logo charge, to get panel customized-contact Spectrum for details
- Unit weight: 2 lb [.91 kg]
- Shipping weight: 2.5 lb [1.14 kg]



### LED Lighting Kit - 37386

- Provides custom backlighting options for corner columns
- Includes RGB LED ribbon, power supply, and RF remote control
- Shipping weight: .5 lb [.23 kg]

*Note: A white column accent (backer) will maximize the brightness effect when used with the optional 37386 LED Lighting Kit.*

*Colored accent panels can be flipped over to reveal white if the LED Kit is purchased later or if white accent is desired.*

### CPU Tray - 37389

- Provides CPU tower storage under worksurface
- Fits CPU's up to 9.13"W x 17.72"D x 19.623"H
- 16ga steel
- Black powder coat
- Each Shoutcaster can support up to 2 CPU trays (1 per side)
- Unit weight: 10 lb [4.5 kg]
- Shipping weight: 11 lb [5 kg]

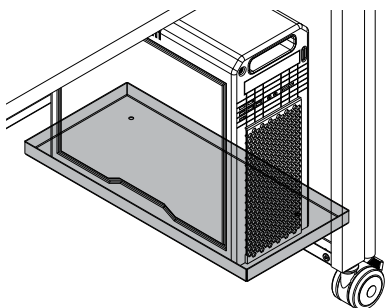

### Adjustable Narrow CPU Sling - 95513

- Provides CPU tower storage under worksurface
- 5"-8.5"W x 18"D x 18"H
- Each Shoutcaster can support (2) CPU slings (1 per side)
- Unit weight: 10.4 lb [4.7 kg]
- Shipping weight: 11.4 lb [5.2 kg]

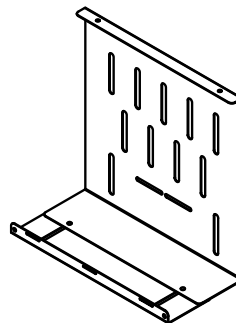



### Esports Xpressions Gaming Chair

**38153 - no logo**  
**38146 - w/ logo**

- Zip in custom embroidered logo panel (6"x9") - (38146)
- Superior back support for hours of sitting in total comfort
- Attractive, modern style to fit any decor
- 4-D adjustable arms with soft gel cushioning
- Height adjustable seat
- Removable and repositionable ergonomic memory foam cushions for the back and head
- 6 sets of interchangeable color base inserts in yellow, red, green, blue, black and white
- Commercial-grade base, built to last in the toughest environments
- Stable and wide 28.5" star base
- Weight Limit: 350 lbs



### Esports Genova Gaming Chair - 38151

- Rugged carbon PVC seat stands up to hours of use
- Optimize ergonomics with the height adjustable seat
- Durable, 2D high-grade plastic arm rests can be adjusted quickly, in both height and rotation
- Fully reclining, 180° tilt mechanism allows you to lay back to stretch or rest up for the next game
- Back and neck pillows are adjustable to provide superior support for extended tournament play
- Available in 6 colors: Red, Yellow, Green, Blue, Purple and White
- Weight Limit: 400 lbs

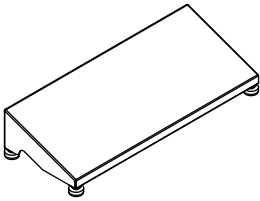

### Esports Footrest - 37348B

- 20-degree tilt provides foot support during extended competition
- 16ga steel
- 24.125"W x 9.4375"D x 4.39"H
- Unit weight: 8 lb [3.2 kg]



### 7-Outlet Power Strip - 99024

- Electrical Rating: AC 125V, 15 Amps
- 1000 Joules surge capacity
- 12' cord length
- LED switch
- UL Listed
- Shipping weight: 1.9 lb [.86 kg]



See [spectrumfurniture.com](http://spectrumfurniture.com) for complete details on Spectrum's full line of monitor arms.

See [spectrumfurniture.com](http://spectrumfurniture.com) for the latest accessories and detailed warranty information.

## Warranty

### **We will make it right for you!**

Thanks for choosing Spectrum! Spectrum is committed to provide complete customer satisfaction. Each of our products is manufactured from the best materials available and each product is stringently monitored throughout the production process through our P.A.C.E. program (Product Assurance to meet Customer Expectations).

We expressly warrant that Spectrum products will be of good quality and workmanship and free from defect for the period set out in the warranty from the date of delivery.

**For a listing of all product specific warranty terms please visit our website at:**

<https://www.spectrumfurniture.com/en/resources/purchasing-terms-warranty>

**1-800-235-1262**

Toll-free HELPLINE

**[spectrum@spectrumfurniture.com](mailto:spectrum@spectrumfurniture.com)**