

# Assembly Instructions

## ⚠ Important ⚠

Before you begin, read and comply with all safety and operating instructions, and ensure all parts and correct quantities are included.

Any parts damaged during shipment must be reported within 5 days of receipt. To report information regarding missing parts or damage, to purchase parts or accessories, or if you have any questions, please contact us.

[www.spectrumfurniture.com](http://www.spectrumfurniture.com)  
800-235-1262, 715-723-6750

*Thank you for purchasing Spectrum products!*



Assembly tip: Do not tighten component fasteners completely until all have been installed. Keeping them loose will help with alignment between parts during assembly.

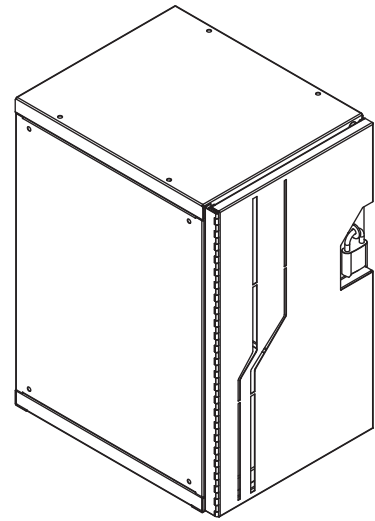

## Esports Locker 37418

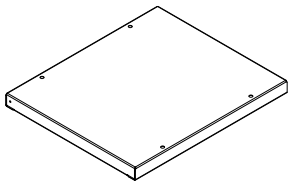

(1) 0172177  
Top panel  
(labeled 'A')

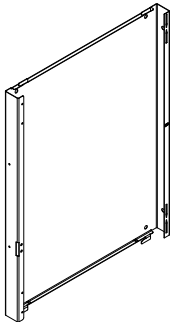

(1) 0171994  
Left side panel  
(labeled 'B')

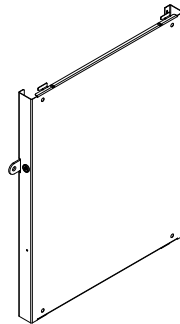

(1) 0171994  
Right side panel assembly  
(w/ hasp and magnet)  
(labeled 'B')

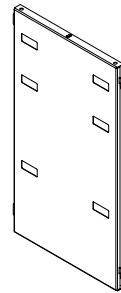

(1) 0171993  
Rear Panel  
(labeled 'C')

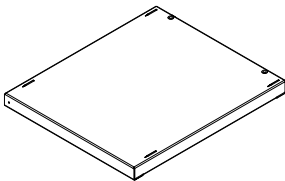

(1) 0172173  
Base  
(labeled 'D')

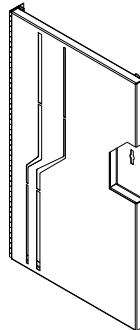

(1) 0172231  
Door Assembly

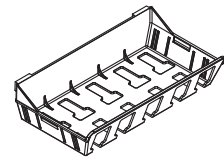

(1) 0119448  
Plastic storage  
tray

### Parts Bag

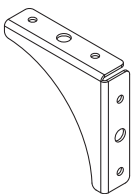

(2) 0160548  
Corner  
Bracket



(1) 0190404  
Re-programmable  
padlock



(12) 035728  
1/4-20 x 1/2"  
PHMS

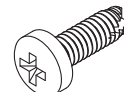

(12) 0100167  
8-32 x 1/2" PH  
Thrd ctg screw



(4) 0106543  
1/4-20 Keps  
nut

## 1 Attach corner brackets to top panel

1. Attach each corner bracket to the top panel (labeled 'A') as shown with (2) 8-32 x 1/2" PH Thrd ctg screws.
2. Do not full tighten screws—they should be loose enough to allow some movement during assembly.

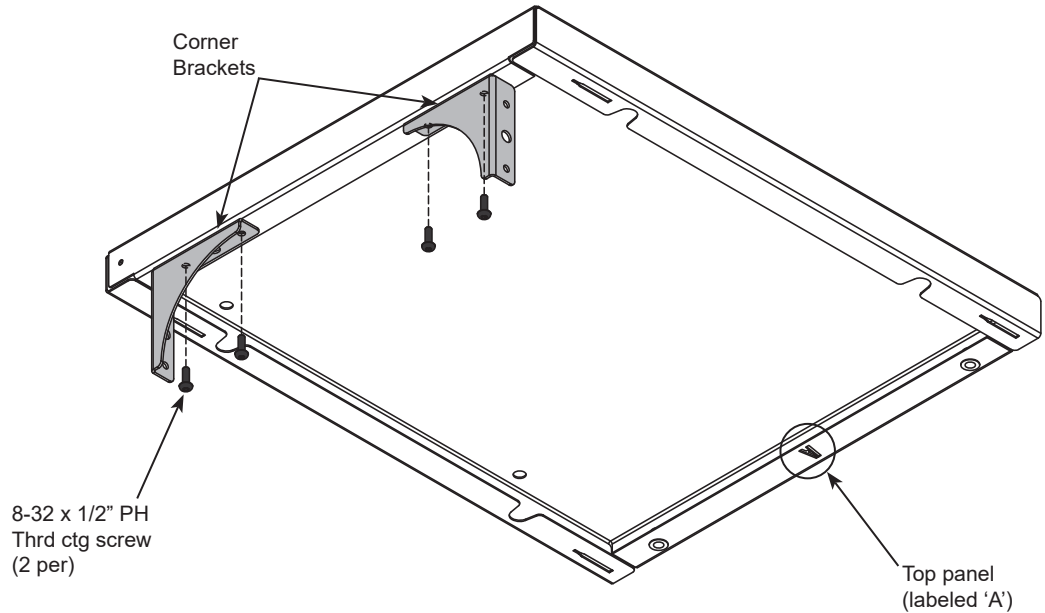

## 2 Attach side panels to rear panel

1. Place rear panel 'C' flange side-down as shown onto a flat surface.
2. Align the tabs of the back panel with the side panel slots.
3. Pull / push the panels as shown to lock tabs into place. All three panels should be aligned at the bottom edge.

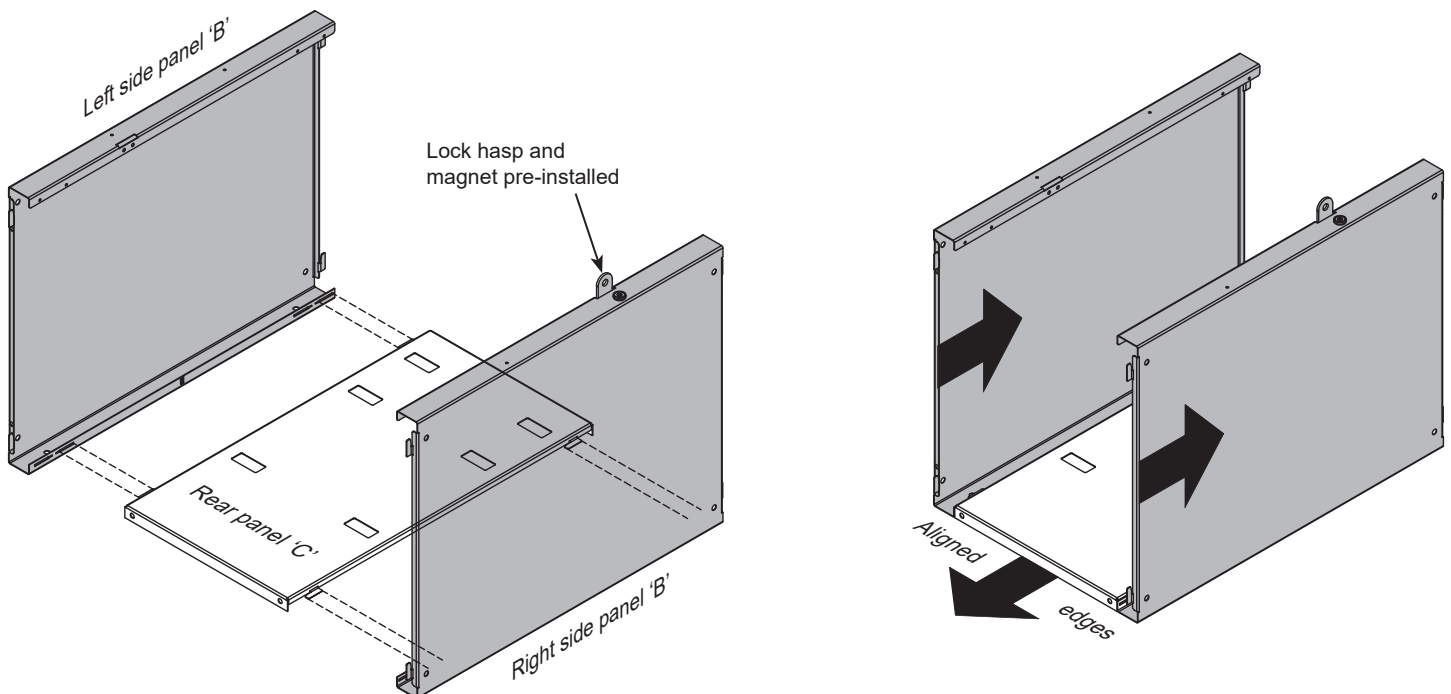

### 3 Attach top and base panels

1. Align the tabs of the side panels with the top and base panel slots.
2. Push the panels down to lock tabs into place. Make sure all panels are aligned.
3. Install the remaining (2) 8-32 x 1/2" PH Thrd ctg screws in each corner bracket but do not tighten completely.

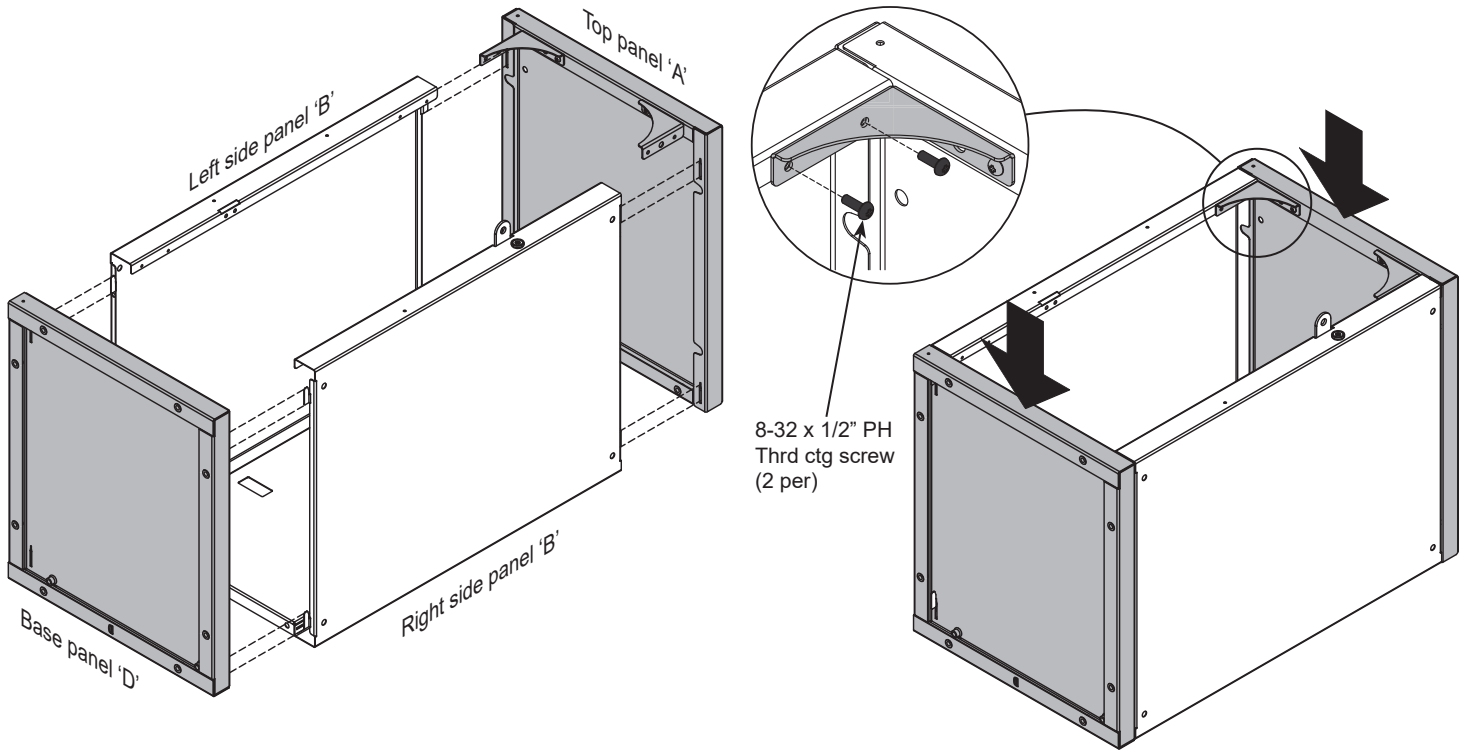

### 4 Secure panels

1. Carefully tip the locker assembly upright.
2. Install (4) 1/4-20 x 1/2" PHM screws at the rear panel to secure the assembly.
3. Securely tighten ALL screws at this point.

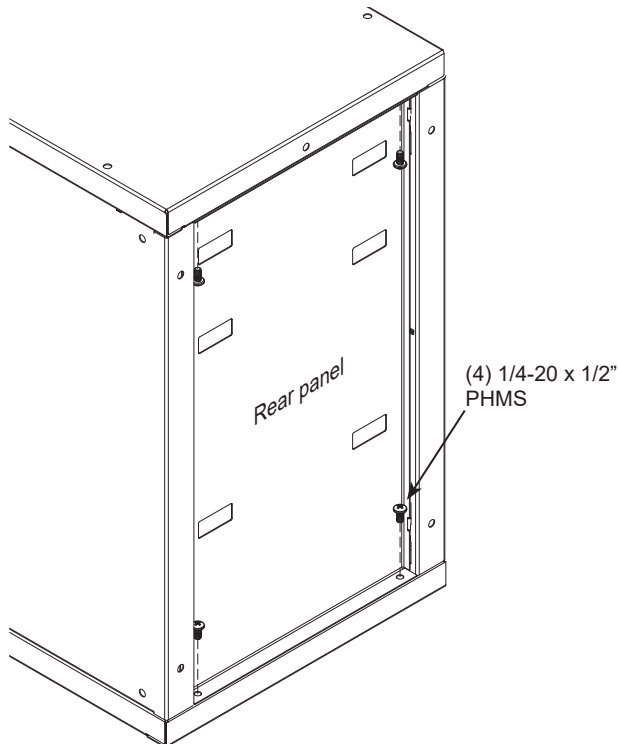

### 5 Attach door assembly

1. Open the hinge and attach the door assembly to the left panel edge with (4) 8-32 x 1/2" PH Thrd ctg screws.
2. Tighten screws securely.

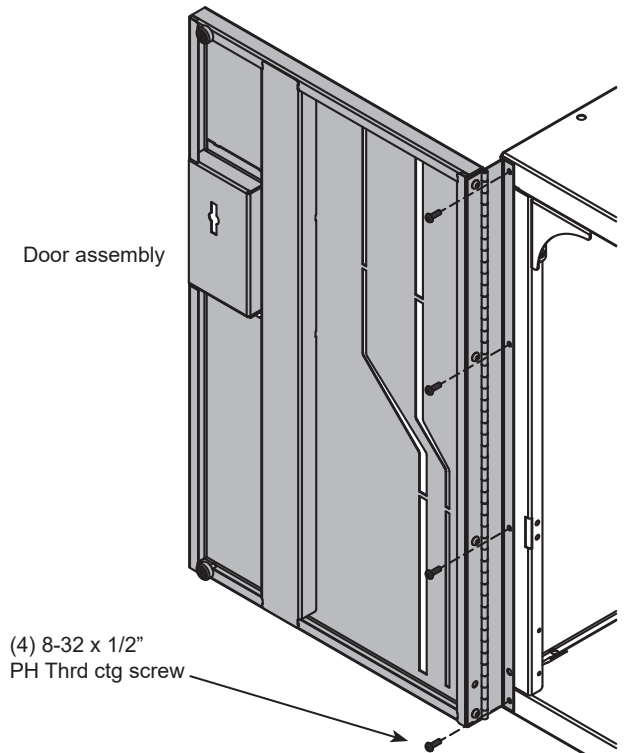

## 6 Connect lockers together

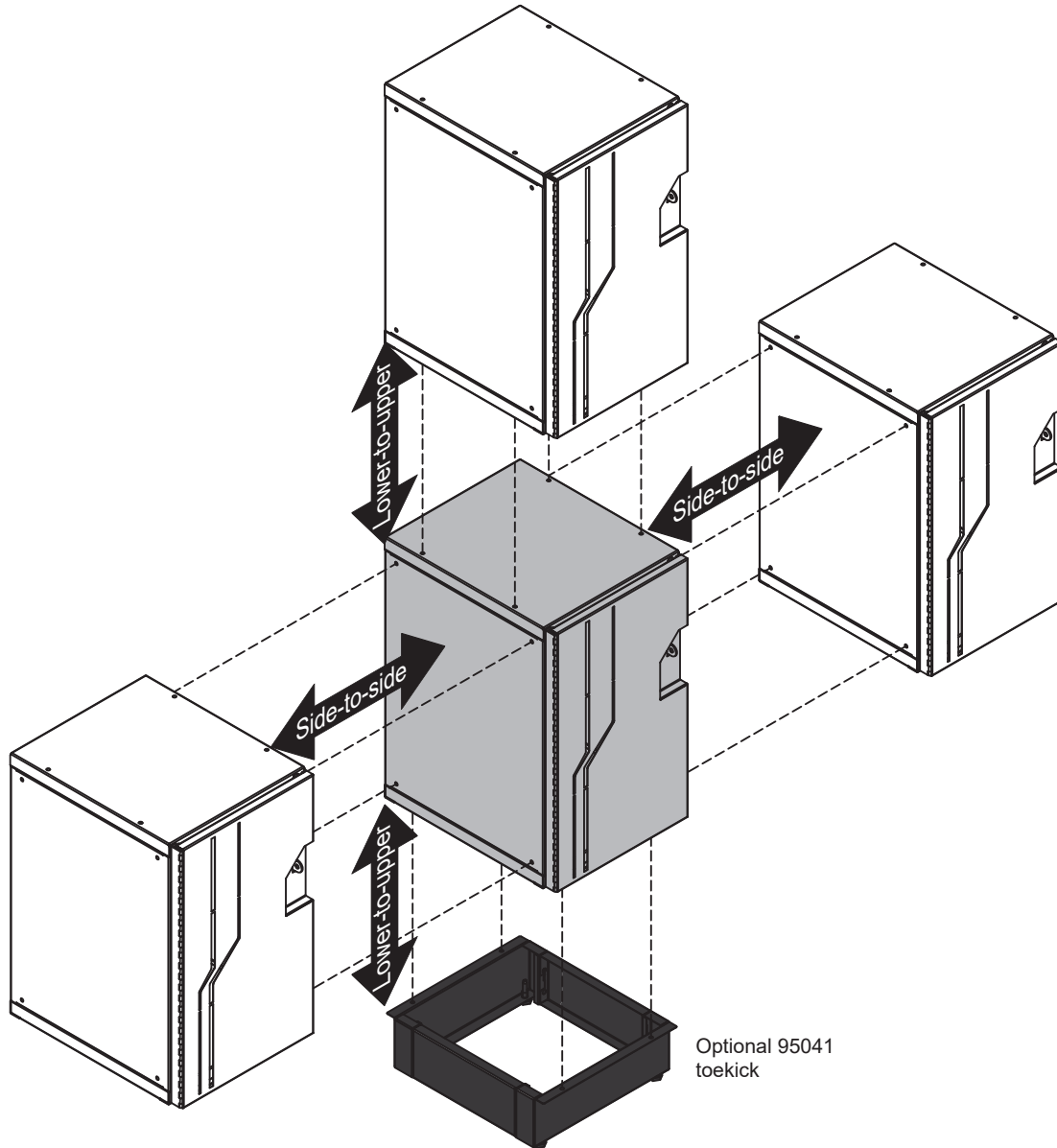

### Fasteners for side-to-side connection

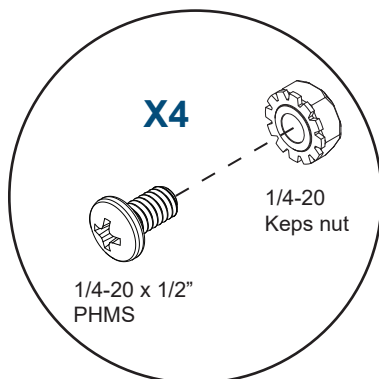

### Fasteners for lower-to-upper connection

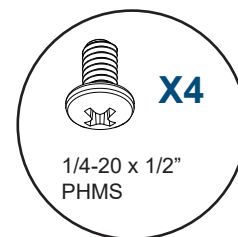

# Stacking Guidelines

Anchored to wall  
(lockers bolted together)

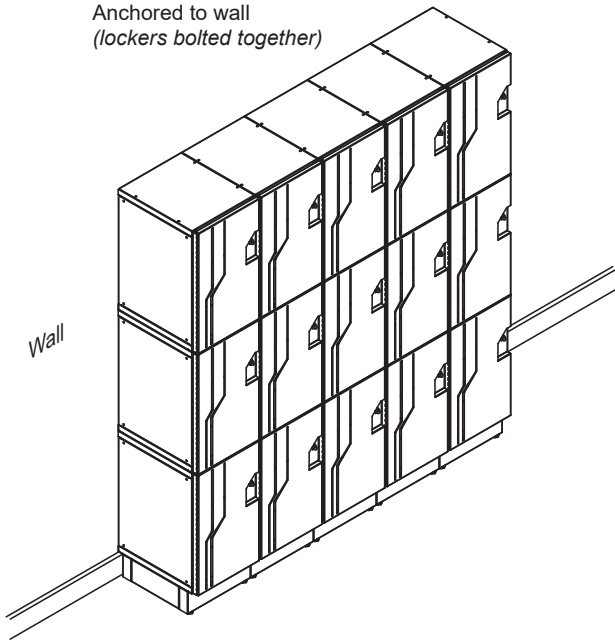

Free-standing back-to-back island  
(lockers bolted together)

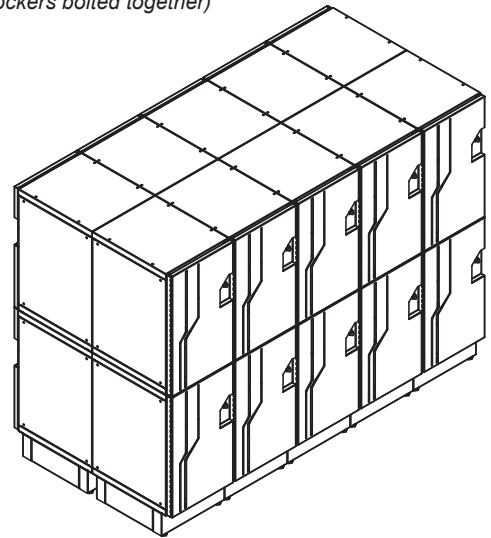

Stacked 3 high on  
optional toekick

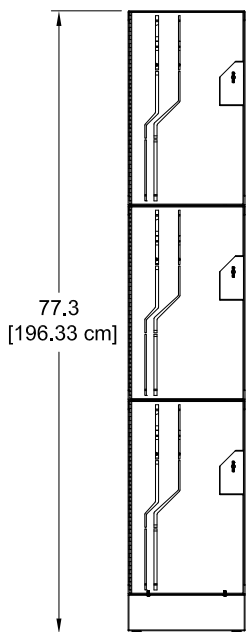

Optional  
toekick

Stacked 2 high on  
optional toekick

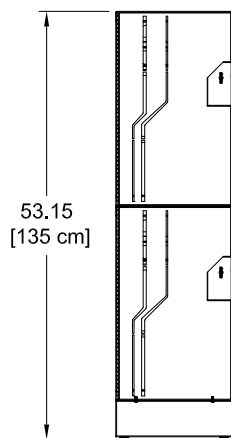

Optional  
toekick

Single on  
optional toekick

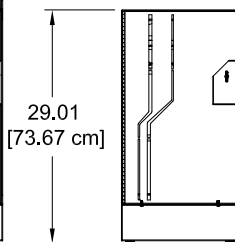

Optional  
toekick

## Wall anchoring

Due to the wide variety of wall materials, wall anchor fasteners are **NOT** provided. Individual job conditions as well as state/local building codes will dictate the type of installation fasteners and how the lockers must be anchored.

(5) 5/16" holes on rear  
for customer-supplied  
wall anchors

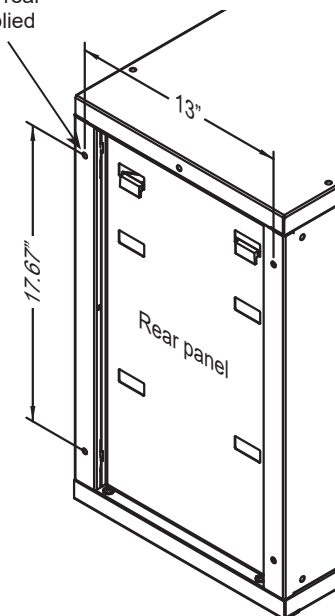

## Accessories

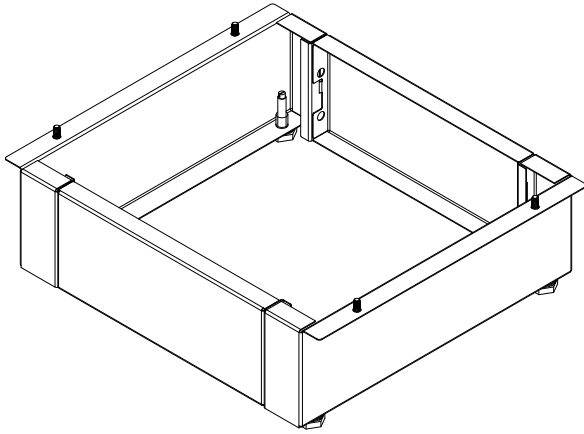

### Toekick - 95041

- Raises single locker stack 5" off floor
- 20-ga steel
- Levelling glides adjust to uneven floors
- Dims: 14.5"W x 16.82"D x 4.9"H
- Black powdercoat
- Unit weight: 6lb [3.6 kg]
- Shipping weight: 7lb [4.1 kg]

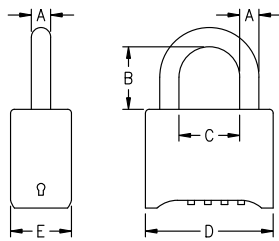

### Re-programmable 4-digit Combination Lock - 95536

- Set your own 4-digit personalized combination (up to 10,000 options)
- 5/16" hardened steel shackle for cut-resistance
- Black powdercoated die-cast body for durability
- Change key included
- Unit weight: .55 lb [.25 kg]

A	.3125" [7.9 mm]
B	1" [25.4 mm]
C	.983" [25 mm]
D	2.07" [52.5 mm]
E	.987" [25.1 mm]