

Technical Specifications

37109	Table (3 required to complete round)
37110	Center Pedestal
37111	Pedestal Riser
37112	Modesty Panel

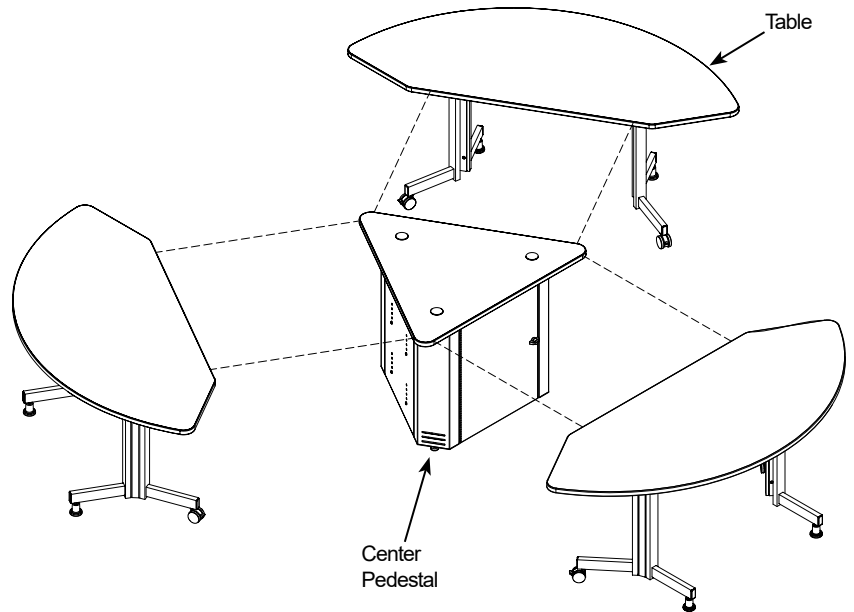
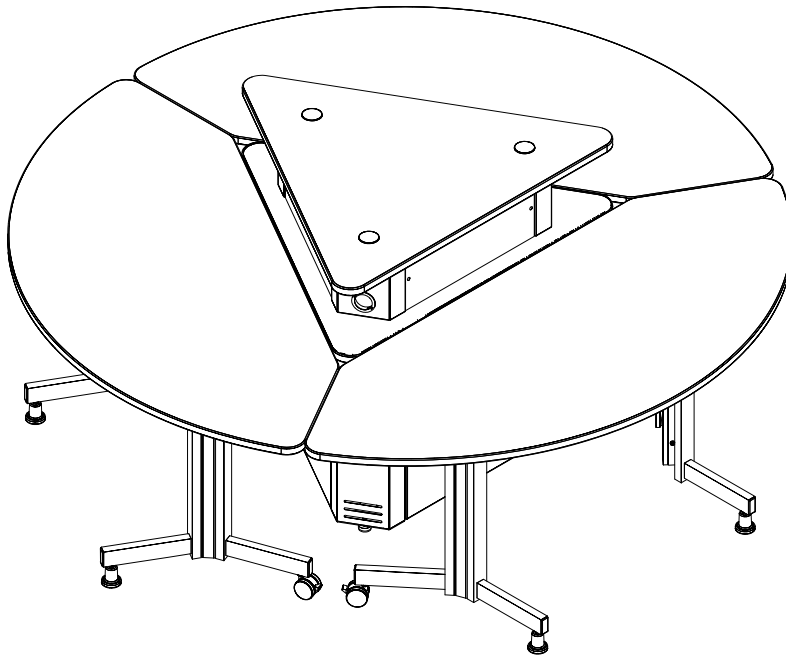

The InVision Active Learning Pod System is a unique solution for collaborative and active learning classrooms where both large group and small group activities are required along with access to technology and ADA-compliant seating. The Pod consists of a Center Pedestal that can hold communication technology and power. An optional riser can be added to make access to the technology easier. Around the Pedestal are three tables that have three seating positions, or one ADA-compliant seating position each. Together, the Pod seats nine adults. The tables can be moved from the Pedestal to form smaller groupings.

Color Options

Available in Spectrum Expressions colors.
See spectrumfurniture.com for complete color information.

Ordering Instructions

Spectrum has designed this product to receive the useful options shown here.
To ensure your options are ordered correctly please call 1-800-235-1262.

Features and Benefits

Table:

- Each table provides seating for up to 3 people with generous knee clearance, and includes 1 ADA-compliant seating position
- Scratch and impact-resistant high-pressure laminate top provides a durable worksurface
- Durable black 3mm T-mold edge protects worksurface edges
- Casters allow any active learning environment to quickly and easily separate into small group settings
- Each table comes with 4 casters and 4 glides. The table can be assembled with all 4 casters for frequent mobility, 4 glides for fixed locating, or 2 casters / 2 glides for occasional mobility.
- Tables can be easily moved to reconfigure as necessary



Center Pedestal:

- Pedestal top panel with black 3mm T-mold edge provides a place to install electrical access or presentation controllers
- Locking center pedestal provides security and easy-access
- Ventilated side panels keep equipment cool
- Monitor arm(s) can be installed on top panel
- Three 2" cable grommets on the top panel provide cable access
- Two adjustable internal shelves provide storage and cord passage for matrix switching devices, scalars, WiFi access points, and other communication devices
- Included floor mounting brackets provide option to bolt permanently to floor

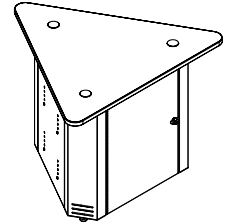

Pedestal Riser: (Center pedestal required)

- Pedestal riser top panel with black 3mm T-mold edge provides a place to install electrical access or presentation controllers
- Removable/customizable vertical riser panels provide a place to install electrical access or presentation controllers-making it much easier to adapt and upgrade to changing technologies (cutouts not included)
- Open mid panel provides access to center pedestal
- Ventilated corner columns keep equipment cool
- Monitor arm(s) can be installed on top panel
- Three 2" cable grommets on the top panel provide cable access



Modesty Panel:

- Easy to install steel panel provides modesty on tables used away from center pedestal

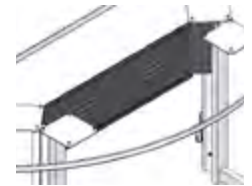

- Durable powder coated steel provides a long-lasting finish
- Warranted to be free of all defects in materials and workmanship for 10 years, electrical system 2 years
- Assembled in Chippewa Falls, WI, USA

Construction

- The worksurface, and top panels are constructed from 1" thick NAF (no-added formaldehyde) composite board with .030" high-pressure laminate on one face, and a balancing phenolic backer on the opposing face
- Metal components consist of 16-gauge and 20-gauge steel
- 16-gauge steel door and corner columns
- Worksurface and top panel edges are covered with 3mm vinyl T-mold edge
- All metal components are finished with a scratch-resistant powder coat epoxy
- All items are shipped knocked-down (KD) and require assembly.

Specifications

Assembled dimensions	84" [213.4 cm] dia x	38"H [96.5 cm] (with pedestal riser) 29"H [73.7 cm] (without pedestal riser)
Table seating capacity	3 seats per table	
Table ADA-compliance*	 (1) ADA-compliant position per table	<i>*Minimum ADA guidelines for knee clearances are 30"W [76.2 cm] x 19"D [48.3 cm] x 27"H [68.6 cm]</i>
2.347" Twin Wheel casters	Weight capacity 100 lb [45.4 kg] each	
Certifications / Compliance	• SCS Indoor Advantage Certified	• Meets or exceeds applicable ANSI-BIFMA test standards
Unit weights (nominal)	76 lb [34.5 kg] - 37109 - Table 60 lb [27.2 kg] - 37110 - Center Pedestal	29 lb [13.2 kg] - 37111 - Pedestal Riser 4 lb [1.8 kg] - 37112 - Modesty Panel
Shipping weight (nominal)	100 lb [45.4 kg] - 37109 - Table 91 lb [41.3 kg] - 37110 - Center Pedestal	39 lb [17.7 kg] - 37111 - Pedestal Riser 10 lb [4.5 kg] - 37112 - Modesty Panel

Specifications subject to change without notice

InVision Pod Table
37109

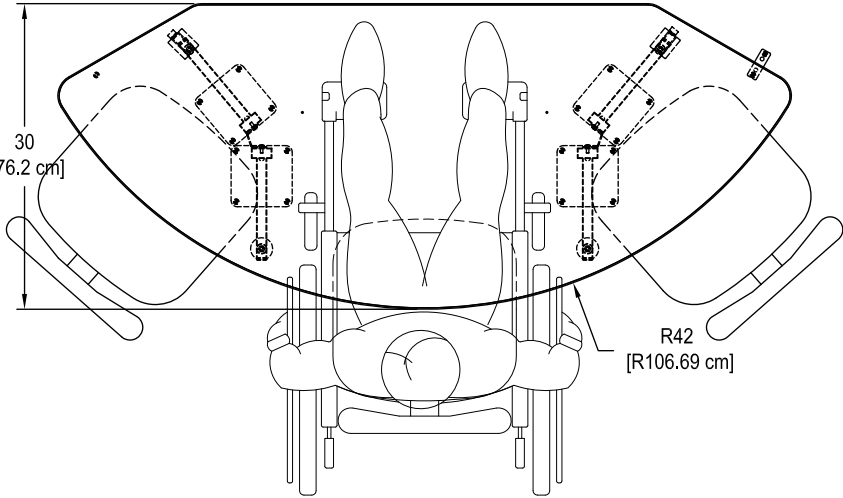
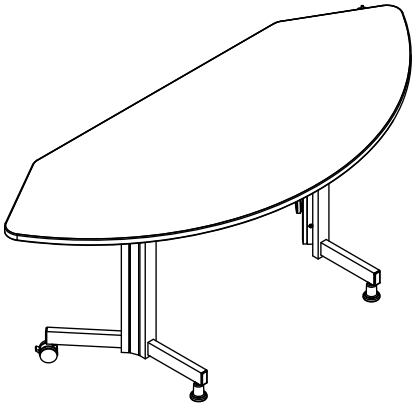

Included with each table:

- 1 - Worksurface
- 2 - Leg assemblies
- 4 - Casters
- 4 - Bell glides
- 1 - Unit-to-unit bracket
- Hardware

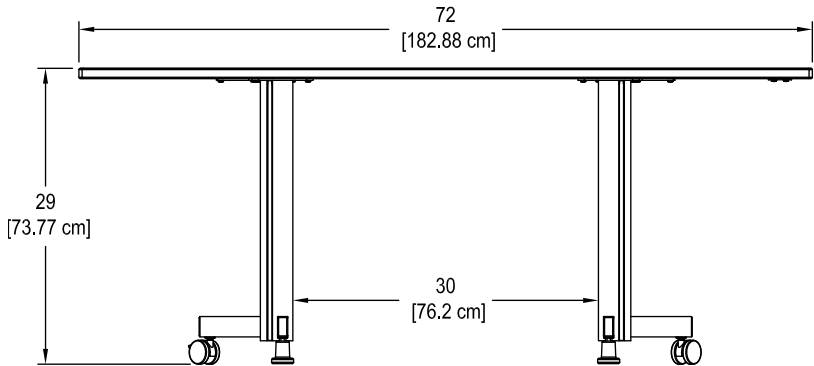
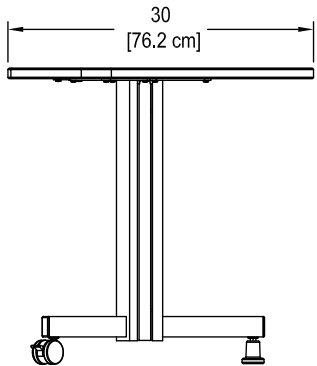

Tables can be setup with:

- 4 Casters for easy mobility
- 4 Glides for fixed in place seating
- 2 Glides and 2 casters

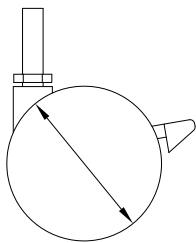
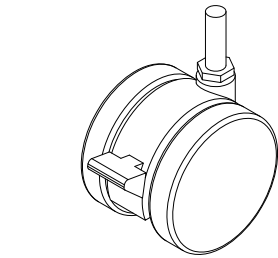

Ø2.347
[Ø5.97 cm]

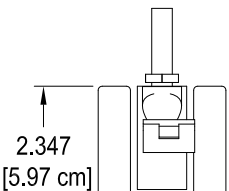

1.9375
[4.92 cm]

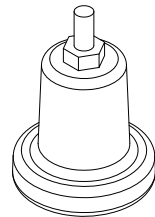

3.1
[7.88 cm]

2.47
[6.28 cm]

2.1674
[5.5 cm]

Note: Casters are made of "soft rubberized" plastic.

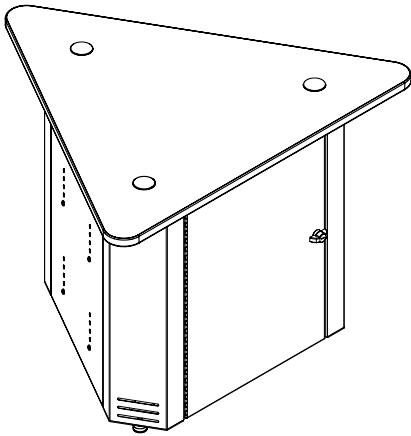

Center Pedestal
37110

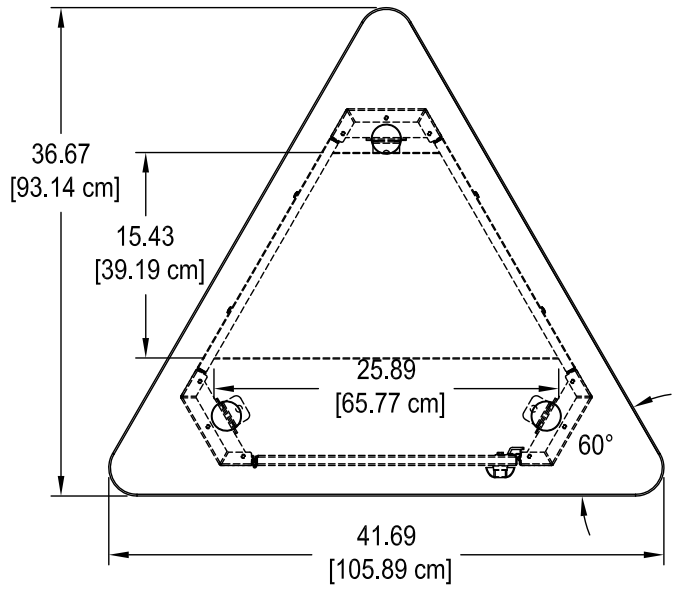

Included with Center Pedestal:

- 1 - Top panel assembly
- 3 - Corner columns
- 2 - Side panels
- 1 - Door assembly
- 3 - Floor mount brackets
- Hardware

Note: Locking door can be installed to be hinged from the left or right side.

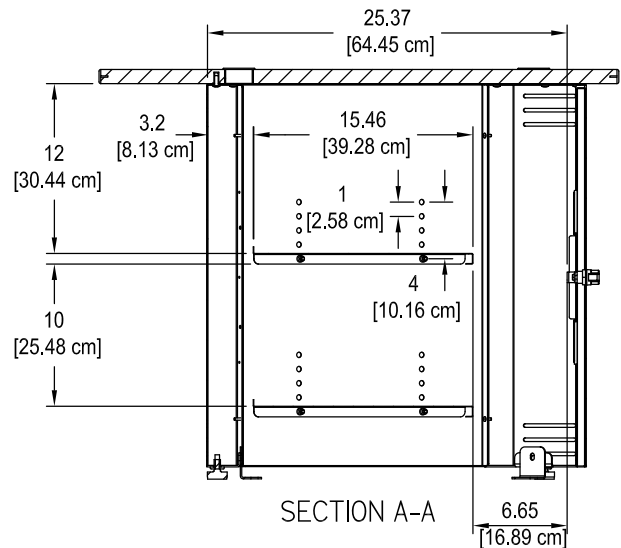
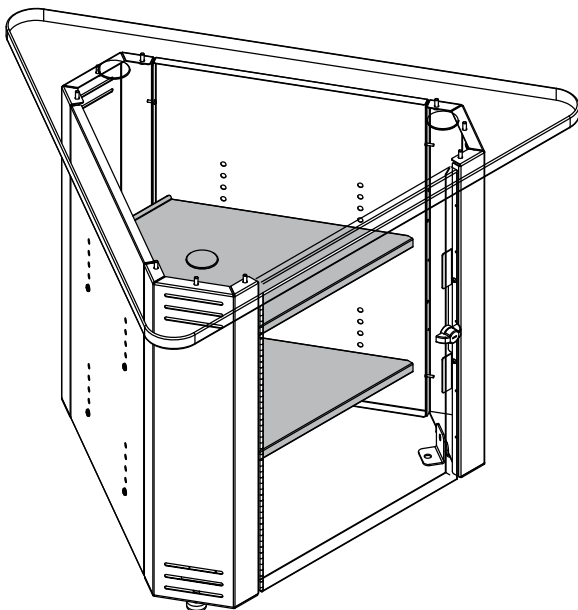
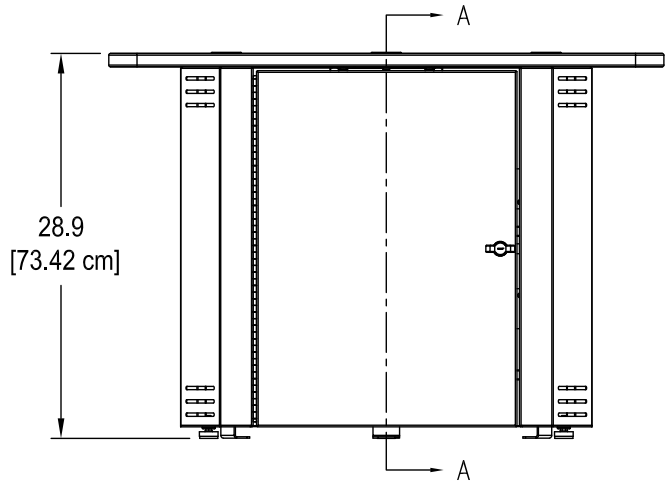
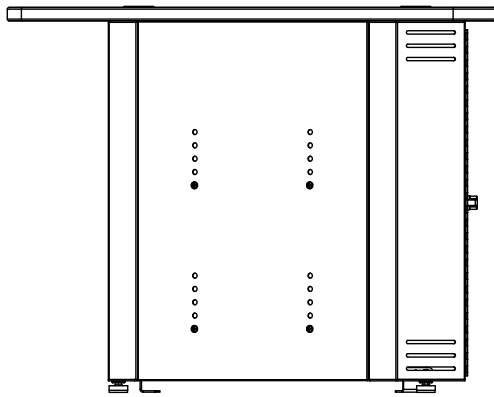

Pedestal Riser
37111
(Center pedestal also required)

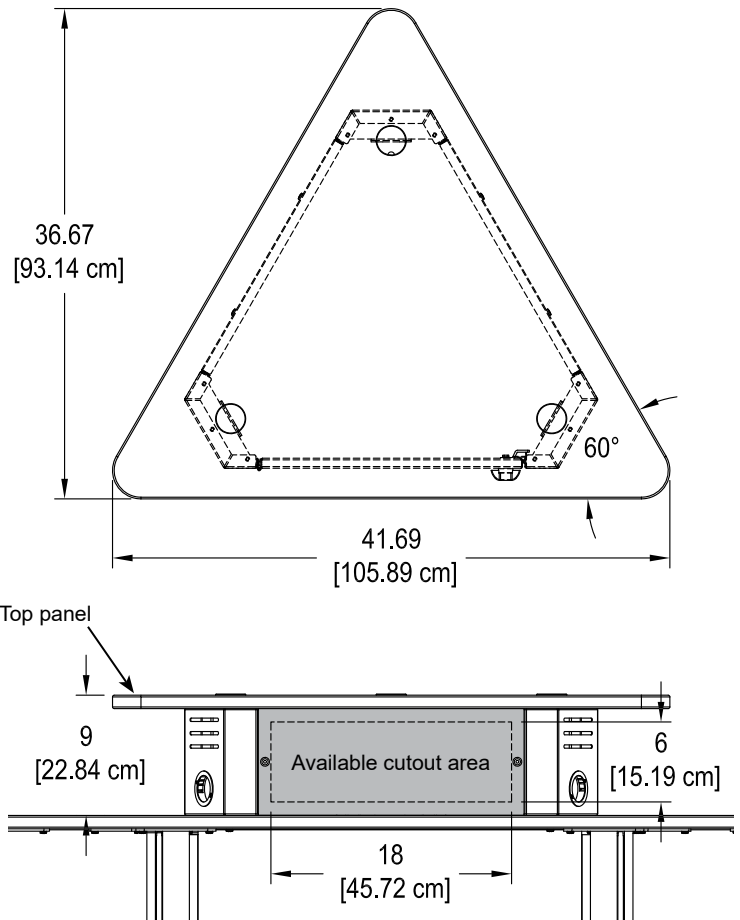
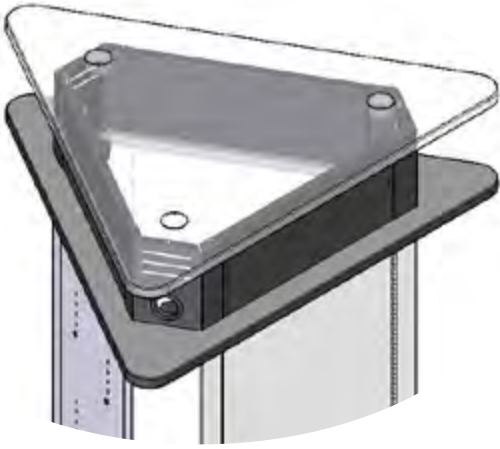

Included with riser:

- 1 - Open panel
- 3 - Corner columns
- 3 - Instrument panels
- Hardware

Note: Top panel on center pedestal gets removed and installed on top of riser.

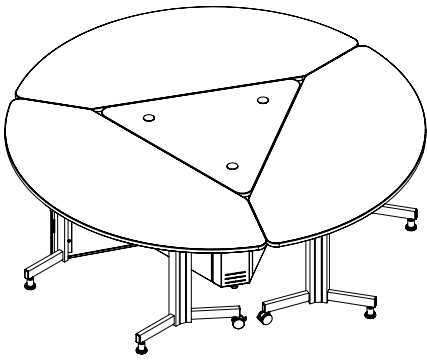

Asembled InVision Pod
(without pedestal riser)

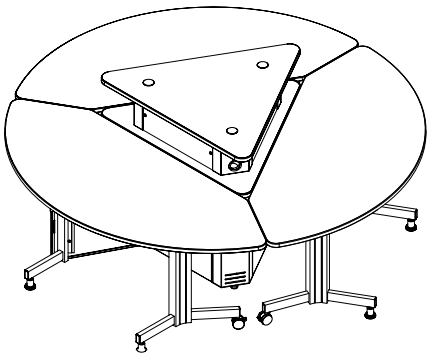
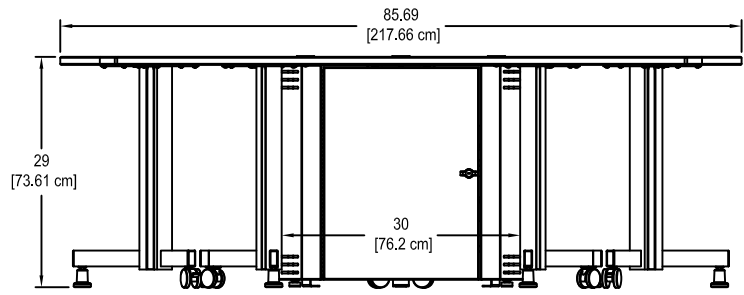

Assembled InVision Pod shown with
pedestal riser and modesty panels

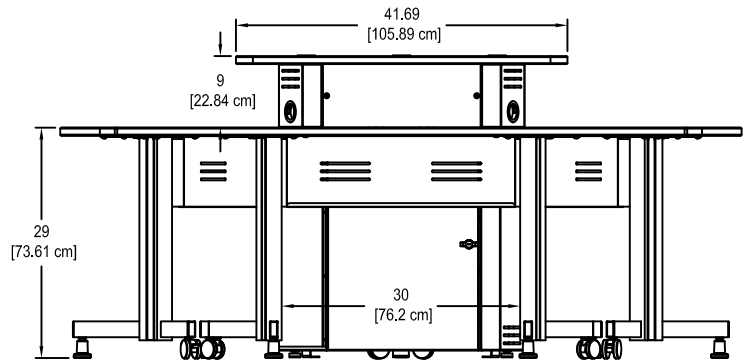

Seating for up to 9

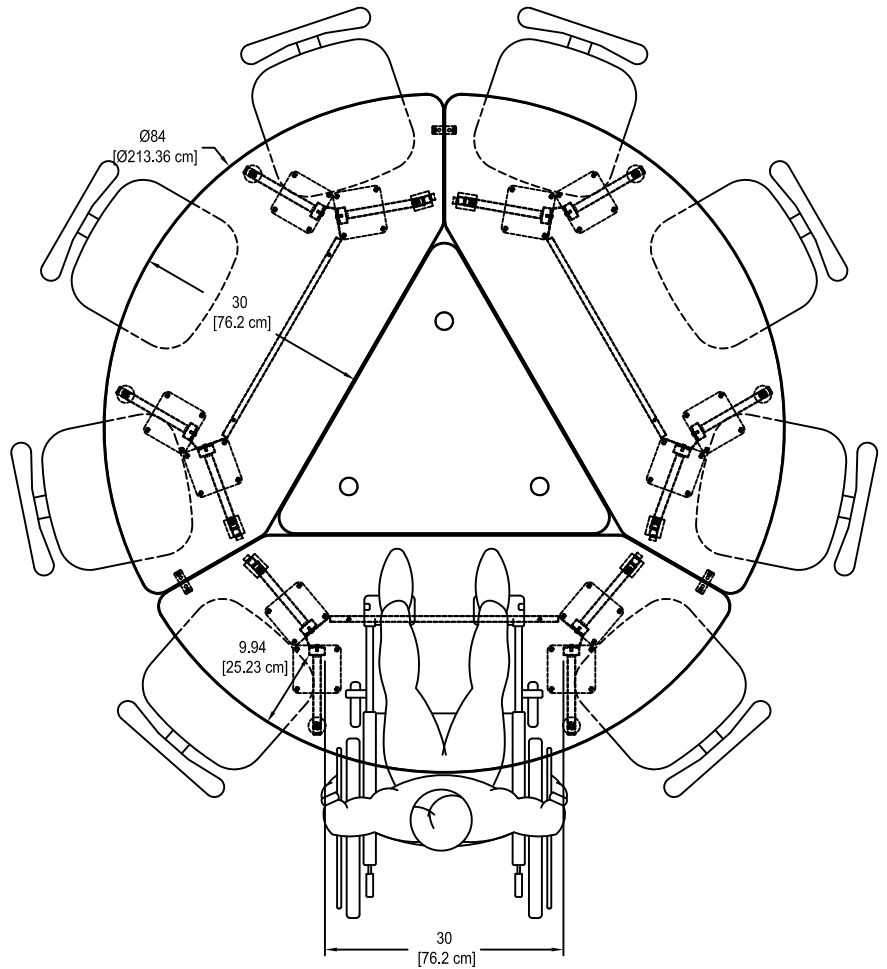

Additional configuration possibilities



Monitors moved toward users into raised and lowered positions

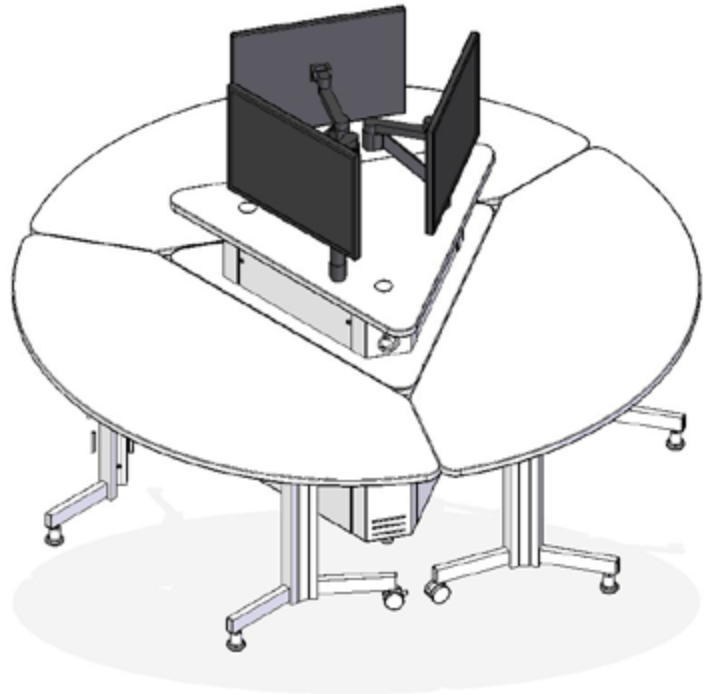

Monitors moved away from users

Note: Up to 3 flat panel monitor arms can be mounted on top of the riser to provide instant sharing screens that do not require expensive complex technology other than a display communication port on the student's computer. With proper arm placement, each monitor can descend below the pedestal riser towards the users preserving line-of-site to the other side of the table or front of the classroom. For the above configuration, each monitor arm requires a .375" [.95 cm] mounting hole drilled through the riser worksurface just behind the instrument panel.

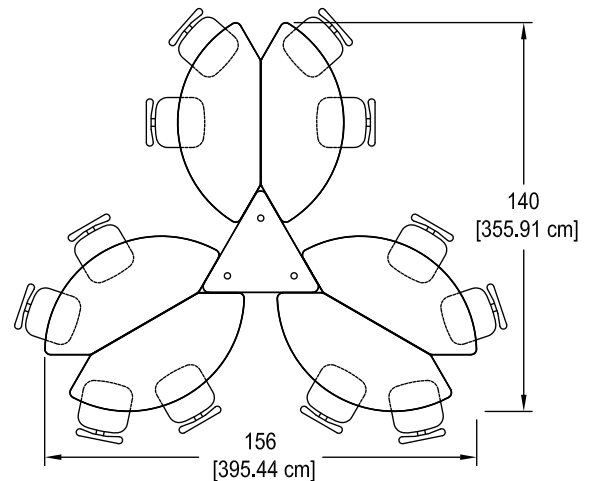
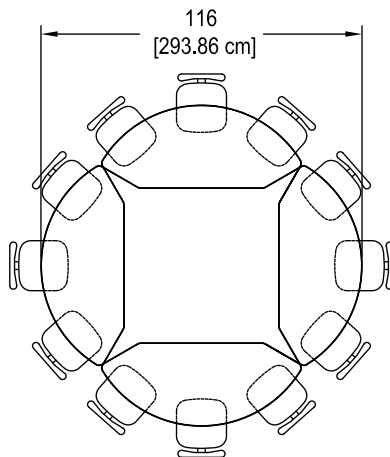
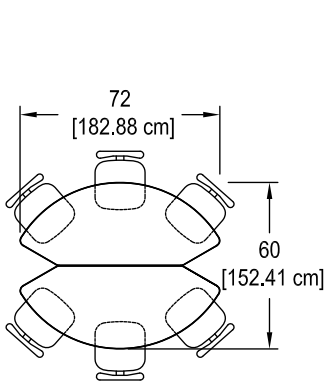

Accessories

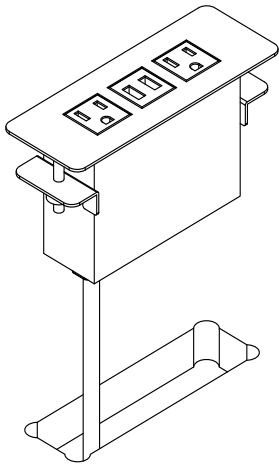

Power Module - 99058

- (2) AC power outlets
- (2) USB charge ports
- Aluminum housing and flange
- Thumbscrew clamps
- Requires worksurface cutout made by customer
- ETL-certified
- Available in black, silver, or white
- Customer-installed

Cutout required:	5.65"W [14.35 cm] x 1.65"D [4.19 cm]
Power cord:	10' [305 cm] 14AWG *3C power cord
Power receptacles:	125V, 60hz, 15A tamper-resistant
USB charging ports:	2.1A (10.5W) (not data-compatible)
Dimensions:	6.38"W [16.2 cm] x 2.36"D [6 cm] x 3.54"H [9 cm]
Unit weight:	2 lb [.9 kg]
Shipping weight:	2.35 lb [1 kg]

Product update

New USB-C Power Module version available. See details at:

www.spectrumfurniture.com



Note: Power modules are typically installed into cutouts made in the pedestal riser instrument panel(s). Cutouts can be made by Spectrum or customer.

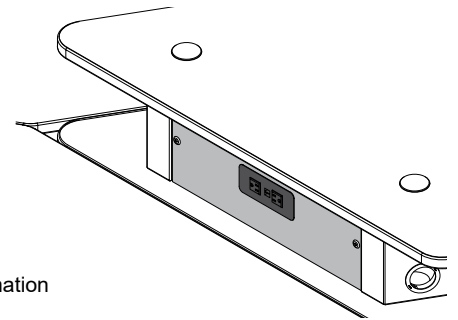

See p.5 for more information



Modesty Panel - 37112

- One per pod table
- Extends 9" below worksurface
- Dimensions: 36"W [91.4 cm] x 9"H [22.9 cm]
- 20-gauge steel
- Available in Black or Silver
- Shipping weight: 5.2 lb [2.4 kg]



Drifter Power and USB Charging Hub - 99040

- 360° Access to Power on three sides (1 AC power outlet and 2 USB charging ports per side)
- Easy installation-table cutout not required
- Includes mounting kit for permanent installations
- Cord length: 9'
- ETL listed
- Available in black or silver
- 10" [28.5 cm] x 2.85" [7.2 cm]
- Shipping weight: 8 lb [3.6 kg]

Warranty

We will make it right for you!

Thanks for choosing Spectrum! Spectrum is committed to provide complete customer satisfaction. Each of our products is manufactured from the best materials available and each product is stringently monitored throughout the production process through our P.A.C.E. program (Product Assurance to meet Customer Expectations).

We expressly warrant that Spectrum products will be of good quality and workmanship and free from defect for the period set out in the warranty from the date of delivery.

For a listing of all product specific warranty terms please visit our website at:

<https://www.spectrumfurniture.com/en/resources/purchasing-terms-warranty>

1-800-235-1262

Toll-free HELPLINE

spectrum@spectrumfurniture.com