

Assembly Instructions

⚠ Important ⚠

Before you begin, read and comply with all safety and operating instructions, and ensure all parts and correct quantities are included.

Any parts damaged during shipment must be reported within 5 days of receipt. To report information regarding missing parts or damage, to purchase parts or accessories, or if you have any questions, please contact us.

www.spectrumfurniture.com
800-235-1262, 715-723-6750

Thank you for purchasing Spectrum products!

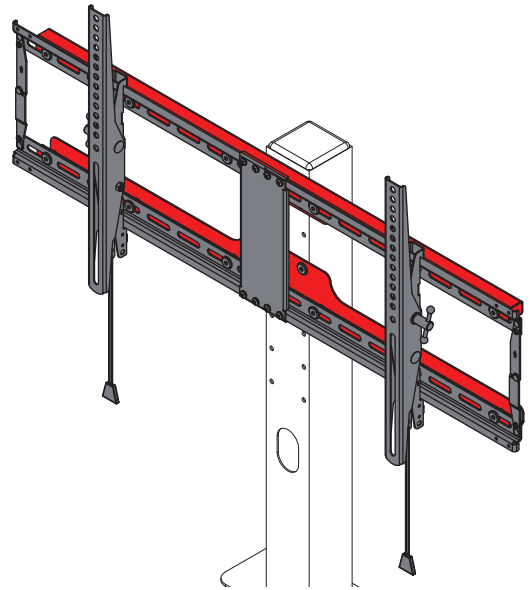

Display Stand 37130

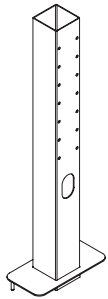

(1) 0118510
Upright assembly

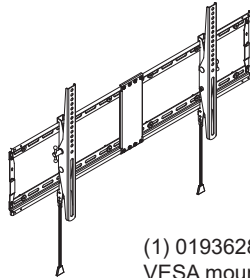

(1) 0193628
VESA mount

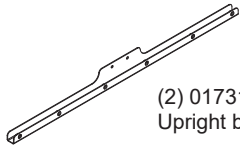

(2) 0173165
Upright bracket



(16) 052605
1/4-20 x 15mm
JC bolt

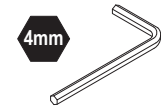

4mm



7/16"

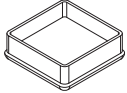

(1) 0118193
End cap 3" x 3"



(4) 0108896
1/4-20 Flanged
serrated locknut

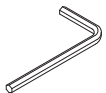

(1) 025039
4mm Hex wrench

Rubber thread
protectors

1 Remove thread protectors

1. With the upright assembly upside-down, remove the rubber thread protector from each threaded stud. **Figure 1.** (A utility knife may be needed to cut off.)

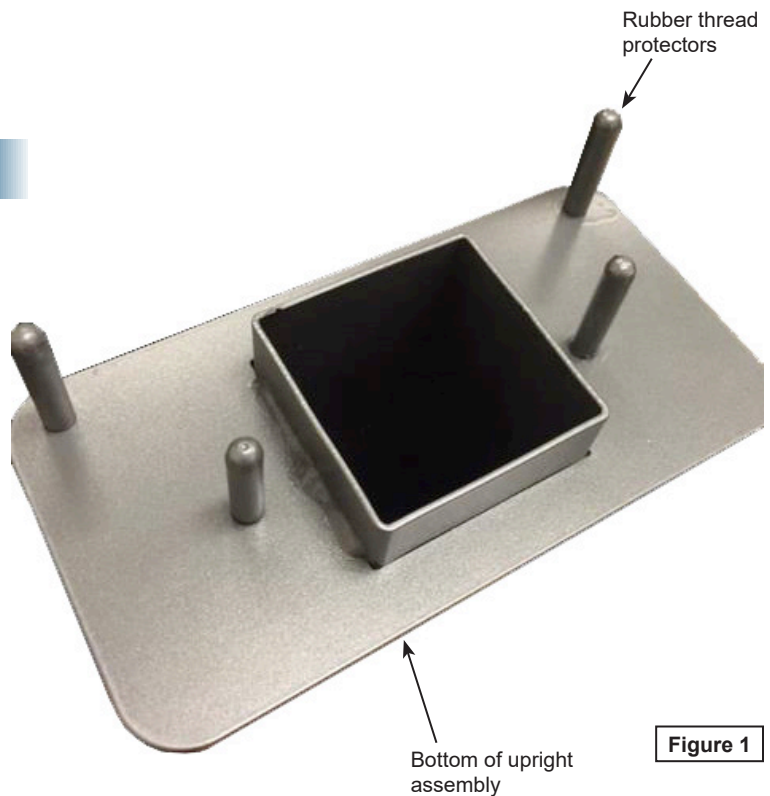

Figure 1

2 Worksurface cutouts

1. Be sure the worksurface being used has the cutout / hole pattern shown in **Figure 2.1**, or **Figure 2.2**.

Mounting holes and cutout needed (on flat end of worksurface)

InVision / Element / Nano Tables

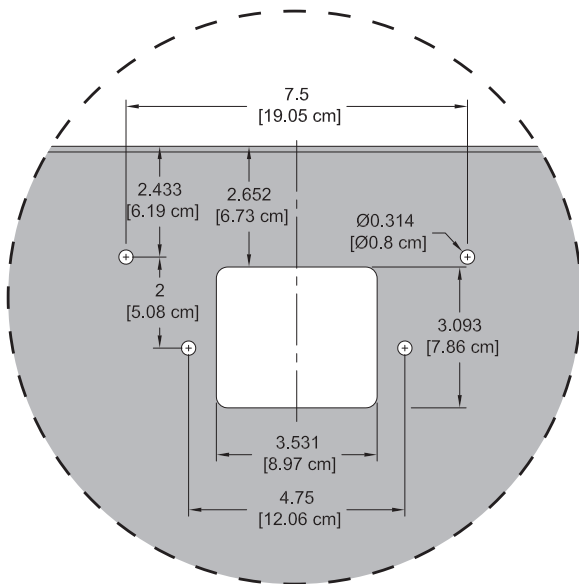

Figure 2.1

Optio Tables

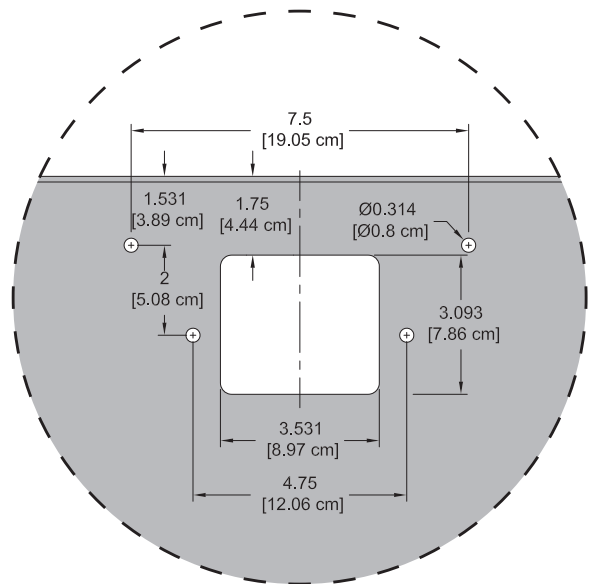

Figure 2.2

2. An unattached worksurface will facilitate installation of the display stand fasteners. If attached, remove the worksurface fasteners securing it to the base and slide the worksurface 6" over the base to provide access to the display stand mounting holes. **Figure 2.3**.
3. Align the studs and insert the upright into the worksurface mounting holes.
4. With a second person holding the upright, install (4) 1/4-20 Flanged serrated locknuts and tighten securely.

Note: For InVision Nano table installation, see p.4 for special instructions.

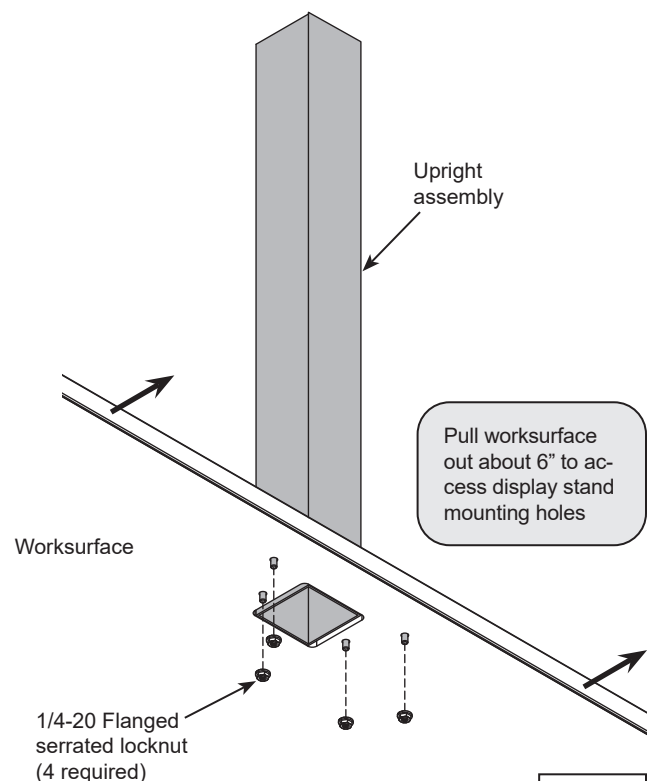

Figure 2.3

3 Install upright brackets

1. Attach the (2) upright brackets to the upright assembly as shown using 1/4-20 x 15mm JC bolts (2 per). Tighten securely.

Note: Multiple mounting holes / height positions are available on the upright assembly). **Figure 3.**

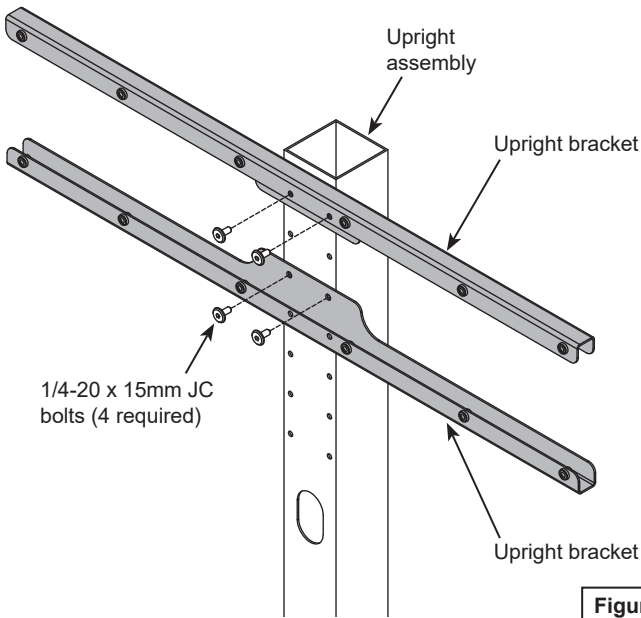

Figure 3

! If installing the display stand onto a Spectrum Console Gaming Hub, be sure the top of the installed monitor will not exceed a 66" height from the floor.

5 Install display

Refer to the instructions included with the display mount for complete VESA / display installation procedure.

1. Refer to the instructions included with the VESA mount for complete display installation procedure. (The hanging rails get installed to the back of the display.)
2. Route cables through the upright opening.
3. Install end cap on top of upright.

!

- The assembled display stand accommodates most 43"-90" displays.
- Be sure display does not exceed the weight capacity of 125 lb.
- If installing the display stand onto a Spectrum Console Gaming Hub, be sure the top of the installed monitor will not exceed a 66" height from the floor.

! WARNING !
The display should always be removed from the stand before moving the unit.

4 Install VESA mount

1. Attach the VESA mount to the (2) upright brackets using (12) 1/4-20 x 15mm JC bolts. **Figure 4.**
2. Tighten all bolts securely

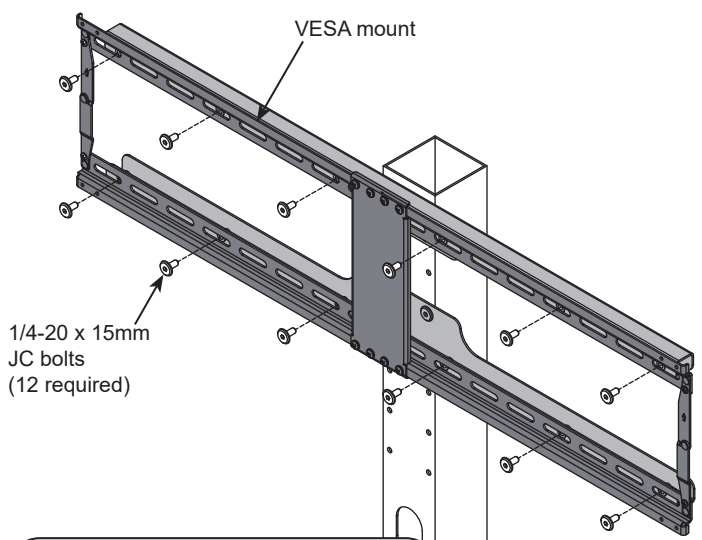

Refer to the instructions included with the display mount for complete VESA / display installation procedure.

Figure 4

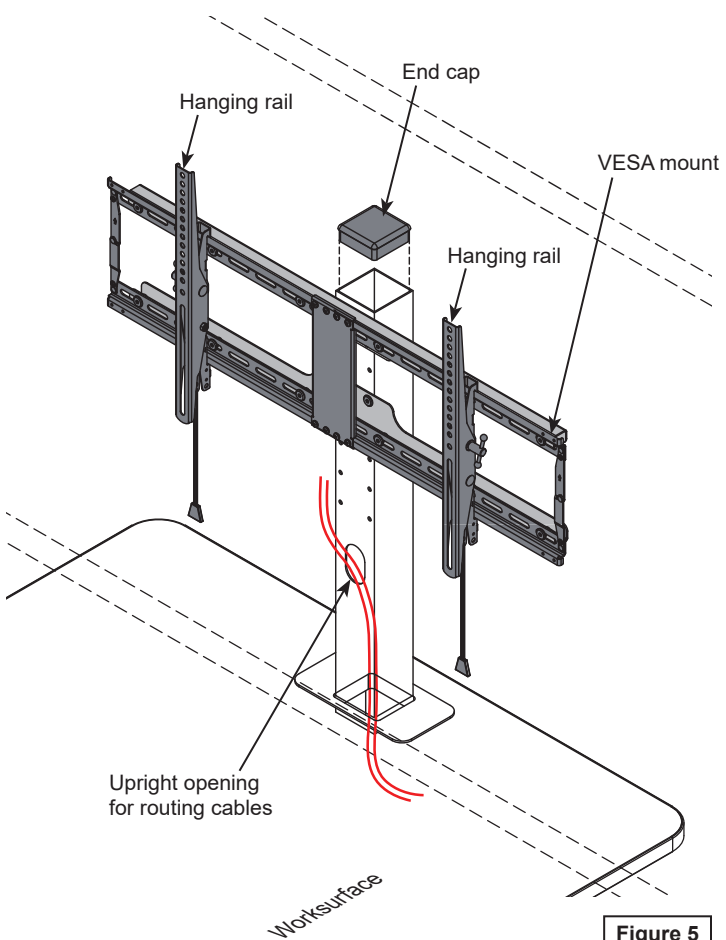

Figure 5

InVision Nano Table Installation addendum

Note: To install the Display Stand on a Nano table, the end panel must be removed prior to installing.

1. Remove the (4) screws shown. **Figure 6.1.**
2. Remove end panel.

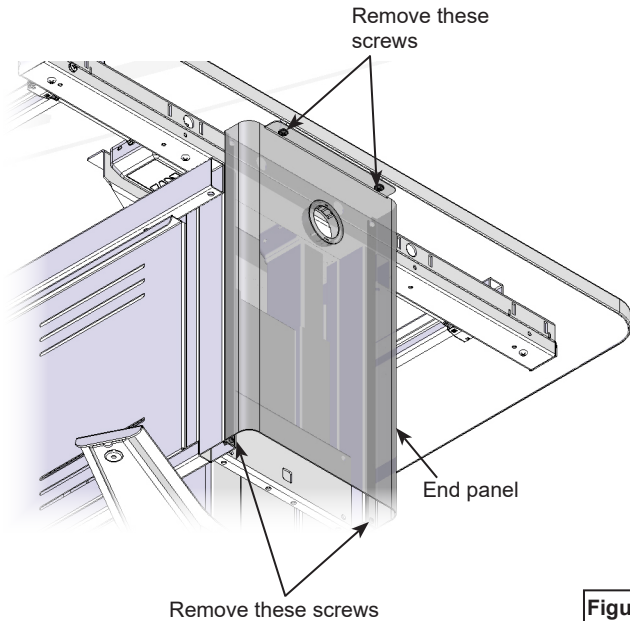

Figure 6.1

3. Align the studs and insert the upright into the worksurface mounting holes.
4. With a second person holding the upright, install the (2) inner 1/4-20 Flanged serrated locknuts. **Figure 6.2.**
5. Replace the end panel.
6. Install the (2) outer 1/4-20 flanged serrated locknuts.
7. Tighten all locknuts securely.

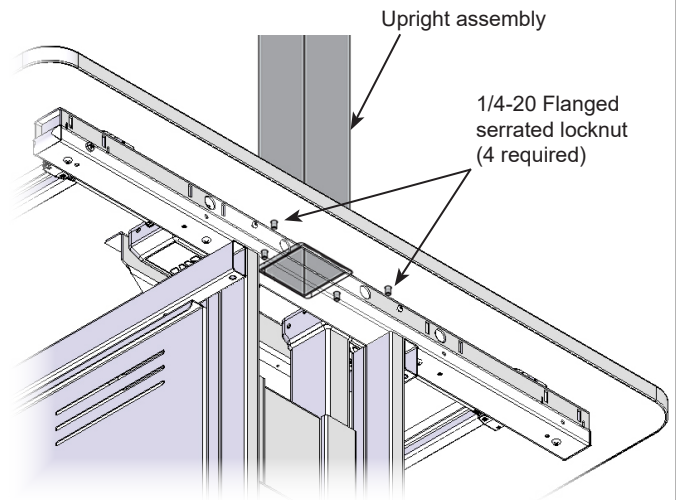

Figure 6.2