

Technical Specifications

95520	with 17.75" [45.1 cm] slide
95531	with 13.75" [34.9 cm] slide (used on select overbridge lecterns)

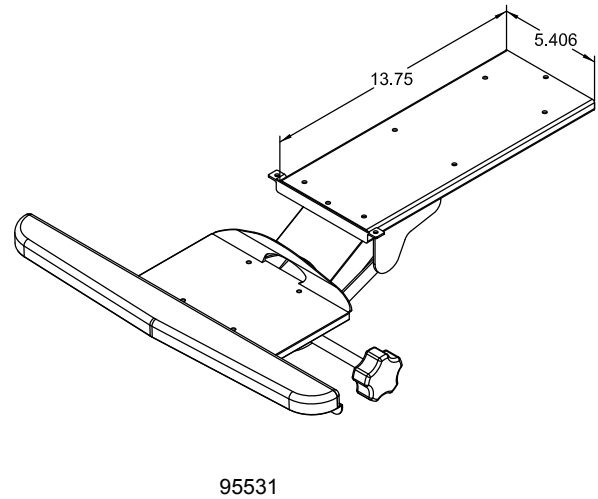
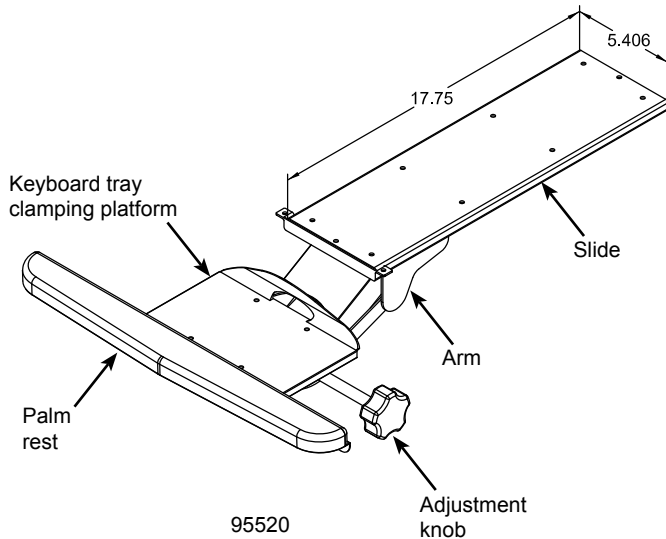

The Econo Keyboard Tray provides adjustability for comfortable and ergonomic keyboarding positioning. Included is an articulating arm, slide, and keyboard tray with palm rest. The tray clamp is easy to operate and will secure most keyboards. The arm adjustment knob on the right side makes height and tilt adjustments simultaneously. The arm features 360° of swivel rotation. The keyboard tray slides under the worksurface when not in use.

Features and Benefits

- Fully retractable keyboard tray slides out of the way when not in use
- Two-piece padded clamping platform accepts most keyboards
- 360° swivel arm for optimal keyboard positioning
- Low profile, single knob sets both tilt (+ / - 15° range) and height (5.75" [14.6 cm] downward travel range)
- 17.75" [45.1 cm] or 13.75" [34.9 cm] slide mounts under worksurface
- Infinite adjustability within specified travel ranges
- Palm rest provides comfort while keyboarding
- Slim profile maximizes clearance underneath when in use or retracted
- Rugged steel construction finished in a durable black textured powder coat
- All mounting hardware and instructions included
- Warranted to be free of all defects in materials and workmanship for 5 years (palm rest 1 year)

Construction

- 14-gauge steel clamp, 12-gauge steel arm / swivel, 17-gauge steel slide
- All metal components are finished with a black scratch-resistant powder coat epoxy
- Assembly and installation to lectern required

Specifications

Capacity	1 Keyboard
Platform clamping range (nominal)	5.375" - 9.25"D (keyboard depth must be within this range)
Vertical travel range	5.75"H [14.6 cm] (below worksurface)
Tilt	+ / - 15°
Slide	17.75"D [45.1 cm] - 95520 13.75"D [34.9 cm] - 95531
Shipping weight (nominal)	14 lb [6.4 kg]

Specifications subject to change without notice

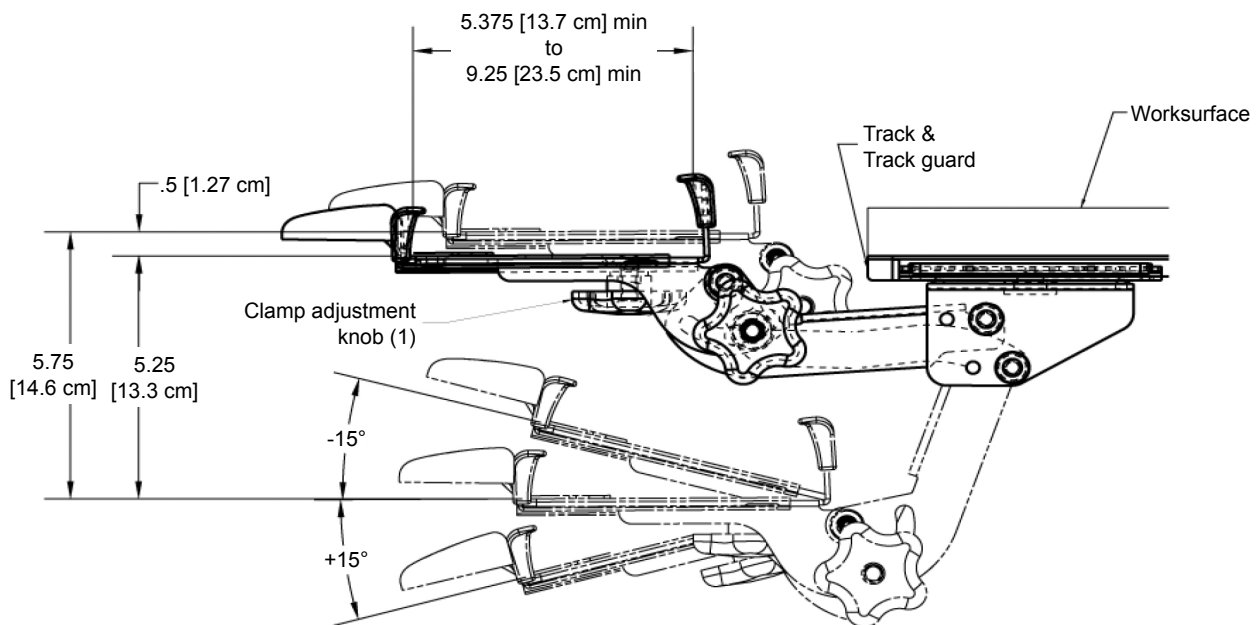
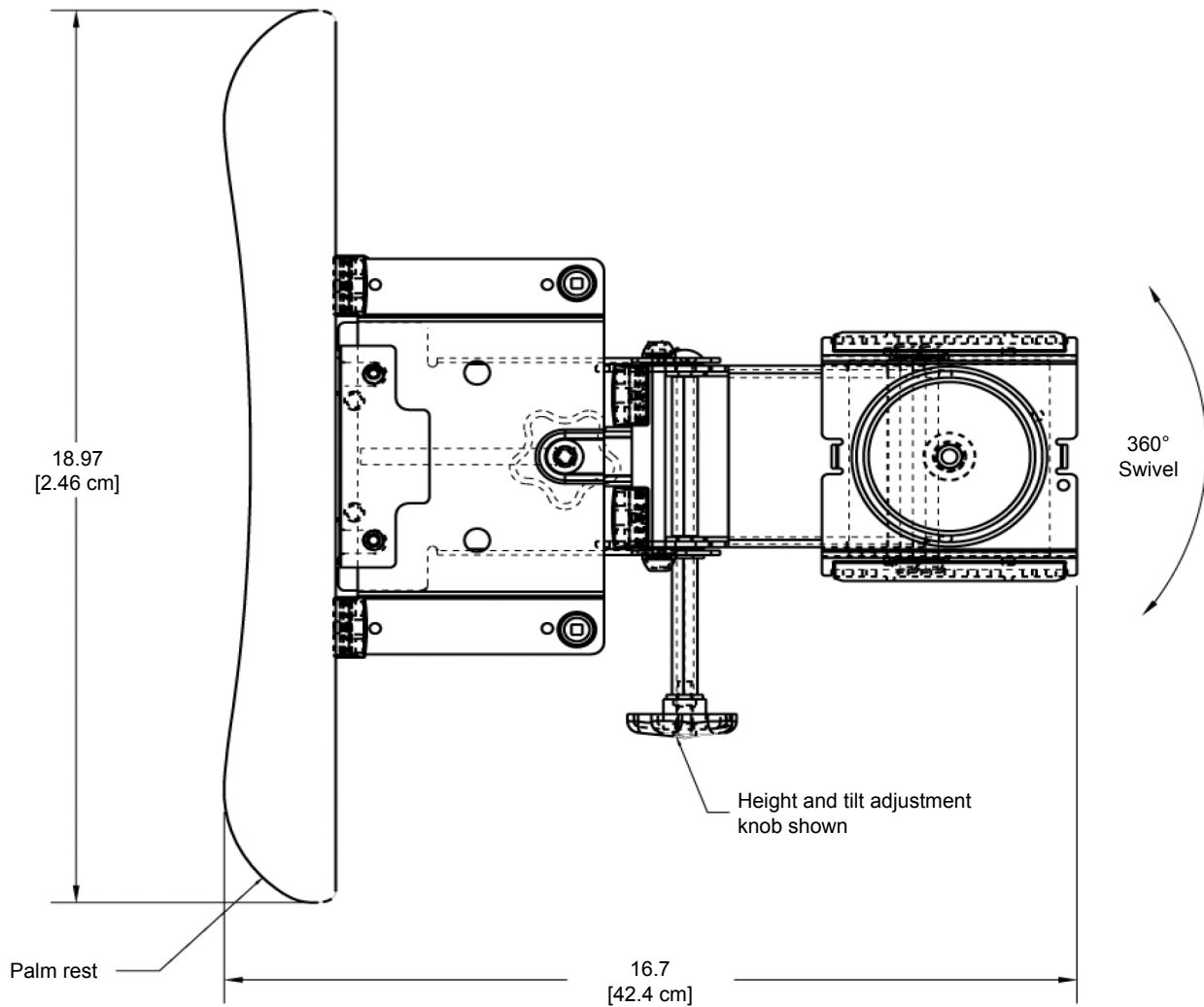

Warranty

WE WILL MAKE IT RIGHT FOR YOU!

Spectrum is committed to provide complete customer satisfaction. Each of our products is manufactured from the best materials available and each product is stringently monitored throughout the production process through our P.A.C.E. program (Product Assurance to meet Customer Expectations).

We expressly warrant that Spectrum products will be of good quality and workmanship and free from defect for the period set out in the warranty table below from the date of delivery. This warranty shall not apply to defects or damage resulting from misuse, abuse, neglect, improper care, modification or repair not authorized by Spectrum, or any other cause outside the control of Spectrum. Spectrum will, at its sole option, either repair or replace the defective product.

This warranty is exclusive; no other warranty, written or oral, is expressed or implied. This warranty is given by Spectrum to Buyer and to no other person or legal entity. No Spectrum dealer, distributor, agent or employee is authorized to make any modification or addition to this warranty.

NOTWITHSTANDING ANYTHING TO THE CONTRARY, SPECTRUM WILL NOT UNDER ANY CIRCUMSTANCES BE LIABLE FOR INDIRECT OR LIQUIDATED DAMAGES, INCLUDING CONSEQUENTIAL, INCIDENTAL AND SPECIAL DAMAGES. IN NO EVENT SHALL SPECTRUM'S LIABILITY, WHETHER UNDER CONTRACT OR WARRANTY, IN TORT OR OTHERWISE, EXCEED THE PURCHASE PRICE RECEIVED BY SPECTRUM FOR THE PRODUCT AT ISSUE AND "RECALL ACTION" EXPENSES. SPECTRUM SHALL NOT BE SUBJECT TO ANY OTHER OBLIGATIONS OR LIABILITIES, WHETHER ARISING OUT OF BREACH OF CONTRACT, WARRANTY, TORT (INCLUDING NEGLIGENCE AND STRICT LIABILITY) OR OTHER THEORIES OF LAW, WITH RESPECT TO PRODUCTS SOLD OR SERVICES RENDERED BY SPECTRUM, OR ANY UNDERTAKINGS, ACTS OR OMISSIONS RELATING THERETO.

Our Customer Service Department is ready to provide immediate attention to any questions, comments or concerns. They are available to answer your calls Monday through Friday from 7 am to 5 pm CST. In addition your product comments or concerns are welcome via e-mail at: spectrum@spectrumfurniture.com.

Warranty Table

Item	Warranty Period effective 1/1/2015
Adjustable Crank / Electric Desk Legs	• 1 Year
Flat Panel Desk Gas Cylinders	
Chairs <ul style="list-style-type: none"> • Adjustable Height Chair Parts – including frames, gas cylinders, wood and plastic parts, control handles, casters • Adjustable Height Chair Upholstery • In-Stock Upholstery • Graded-In Fabrics and Customer Owned Material 	<ul style="list-style-type: none"> • 7 Years • 2 Years • 2 Years • No Warranty
Height Adjustable Columns and Lifts	• 1 Year
General Use Casters	
Electrical (including timers and LINAK actuators)	• 2 Years
Keyboard / Mouse Trays	• 1 Year
Flat Panel Monitor Arms <ul style="list-style-type: none"> • Flat Panel Monitor Arm – General Parts • Flat Panel Monitor Arm – Gas Cylinders 	<ul style="list-style-type: none"> • 5 Years • 2 Years
Desks and Lecterns <ul style="list-style-type: none"> • Computer Desk Chassis • Cart Chassis • Lectern Chassis 	• 10 Years

