

## Technical Specifications

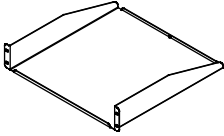

**Cantilever Shelf - 2RU**  
97504

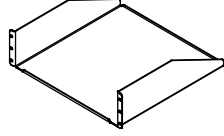

**Cantilever Shelf - 3RU**  
97502

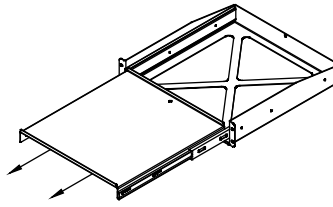

**Pull-Out Shelf - 2RU**  
97505

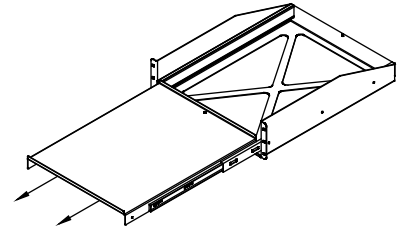

**Pull-Out Shelf - 3RU**  
97503

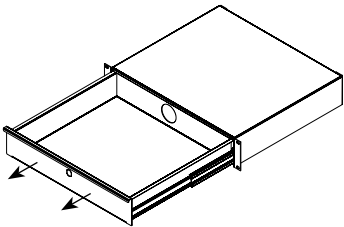

**Locking Drawer (2RU)**  
97523

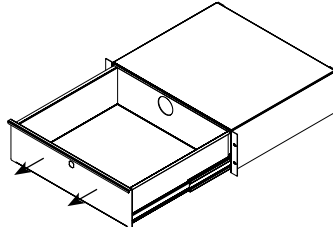

**Locking Drawer (3RU)**  
97522

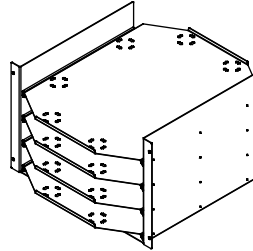

**LT-4 Laptop Storage Unit - 7RU**  
97517

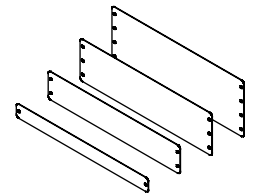

**Rack-Mount Blanks**  
(fills rack spaces where components are not needed)

- 97510 - 1RU
- 97511 - 2RU
- 97512 - 3RU
- 97513 - 4RU

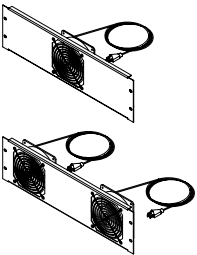

**Cooling Fans - 3RU**  
97507 - Single Fan  
97506 - Double Fan

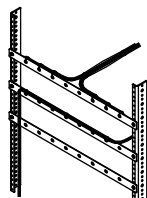

**Wire Lace Kit**  
95517

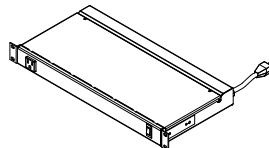

**9-Outlet Power Strip - 1RU**  
99021

### Color Options



Metal:  
Black

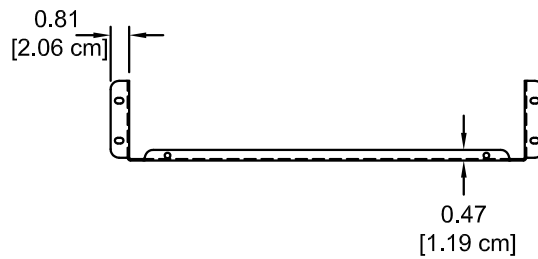
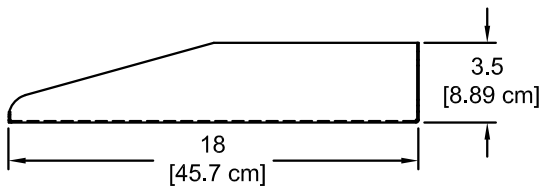
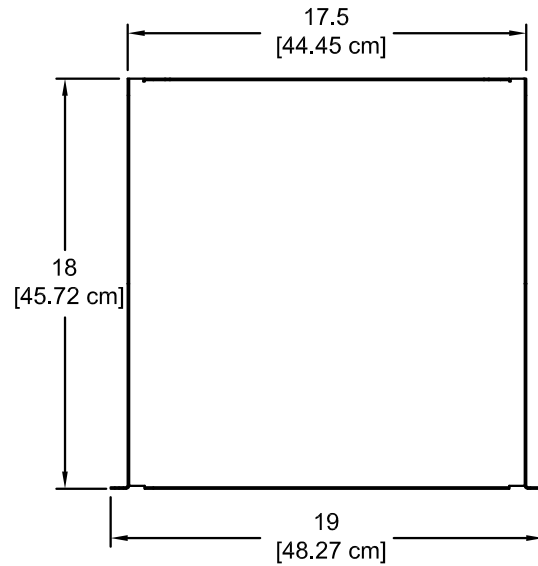
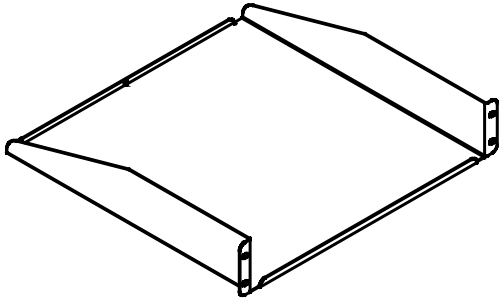

## Features and Benefits

- Mounts to standard rack rails
- Durable powder coated steel provides a long-lasting finish
- Meets or exceeds applicable ANSI-BIFMA test standards
- Made in Chippewa Falls, WI, USA

## Specifications

Weight Capacity	50 lb [22.7 kg]
Material	16 ga steel
Rack units required	2RU
Shipping weight (nominal)	8.1 lb [3.7 kg]

*Specifications subject to change without notice*

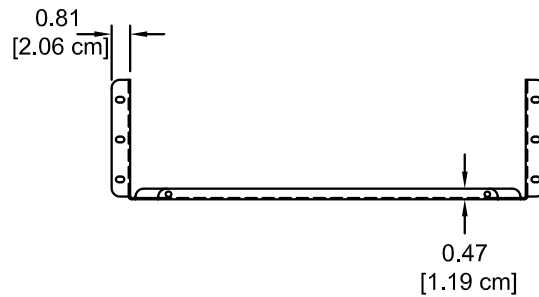
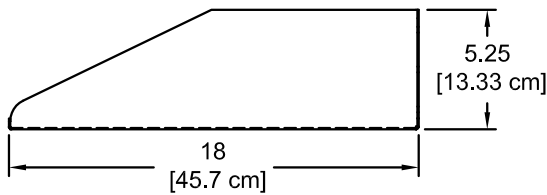
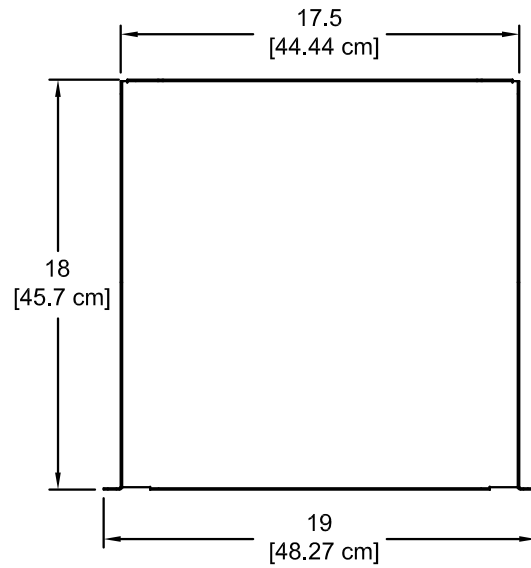
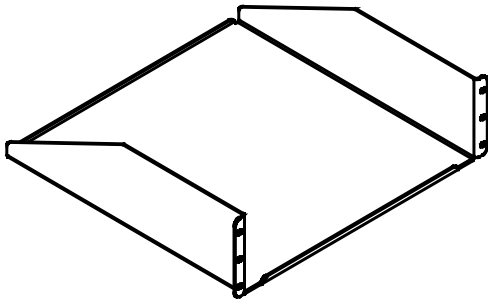

## Features and Benefits

- Mounts to standard rack rails
- Durable powder coated steel provides a long-lasting finish
- Meets or exceeds applicable ANSI-BIFMA test standards
- Made in Chippewa Falls, WI, USA

## Specifications

Weight Capacity	80 lb [36.3 kg]
Material	16 ga steel
Rack units required	3RU
Shipping weight (nominal)	9.2 lb [4.2 kg]

*Specifications subject to change without notice*

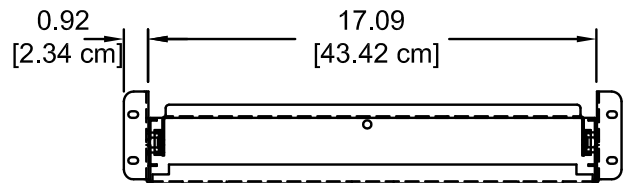
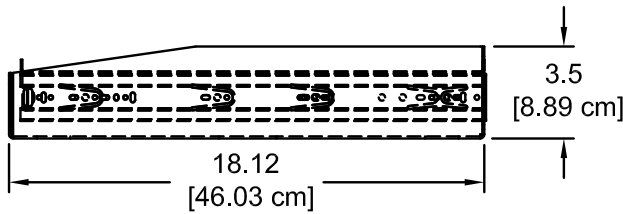
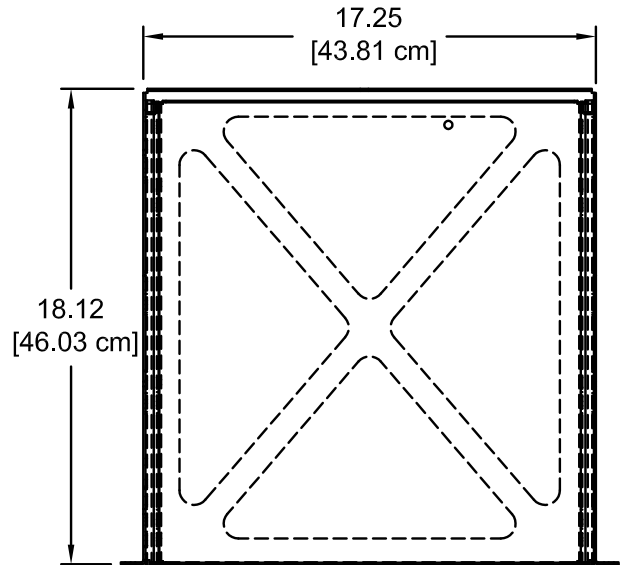
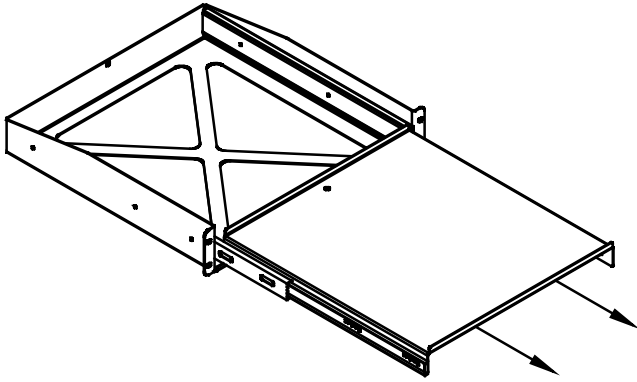

## Features and Benefits

- Mounts to standard rack rails
- 18° slides
- Durable powder coated steel provides a long-lasting finish
- Meets or exceeds applicable ANSI-BIFMA test standards
- Made in Chippewa Falls, WI, USA

## Specifications

Weight Capacity	50 lb [22.7 kg]
Material	16 ga steel
Rack units required	2RU
Shipping weight (nominal)	15.6 lb [7.1 kg]

*Specifications subject to change without notice*

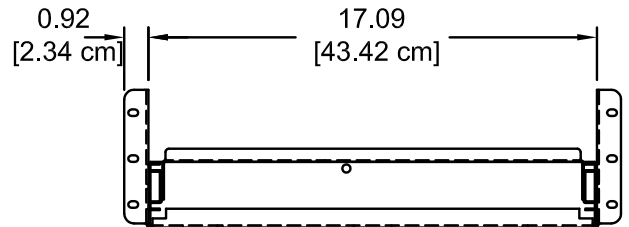
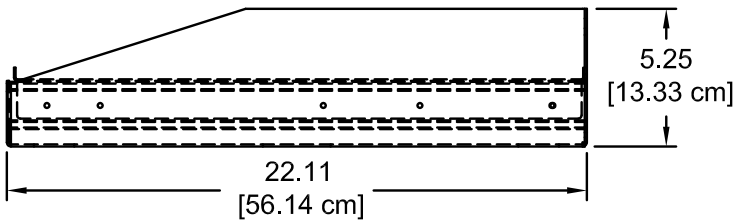
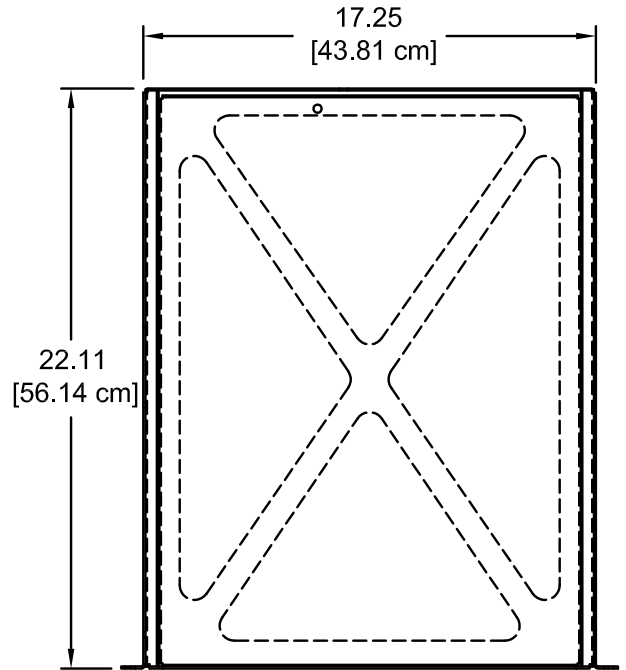
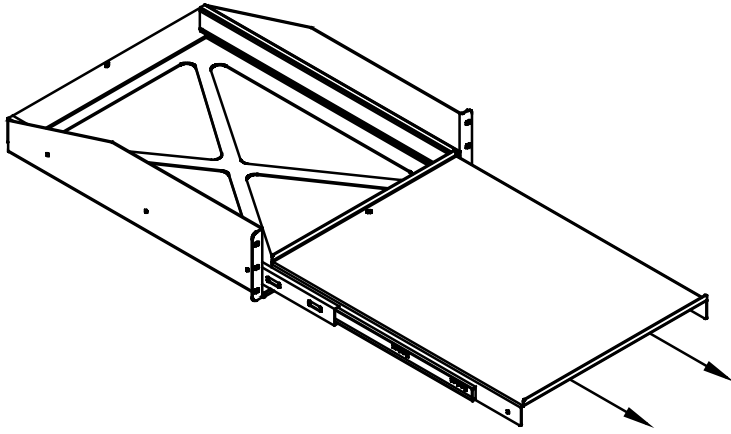

## Features and Benefits

- Mounts to standard rack rails
- Durable powder coated steel provides a long-lasting finish
- Meets or exceeds applicable ANSI-BIFMA test standards
- Made in Chippewa Falls, WI, USA

## Specifications

Weight Capacity	80 lb [36.3 kg]
Material	16 ga steel
Rack units required	3RU
Shipping weight (nominal)	20.9 lb [9.5 kg]

*Specifications subject to change without notice*

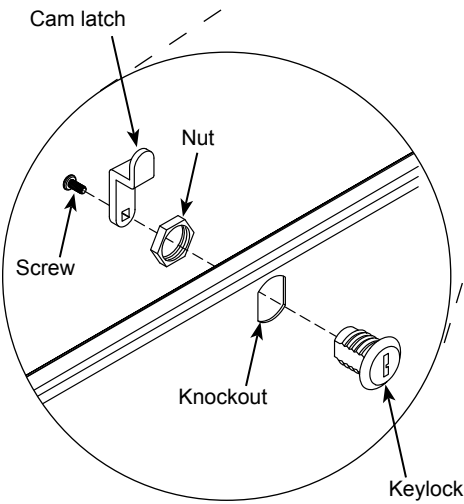
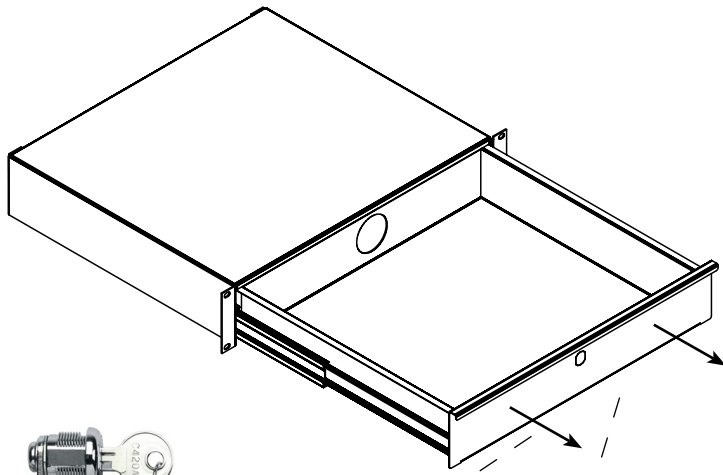

Keylock Assembly  
(customer-installed)

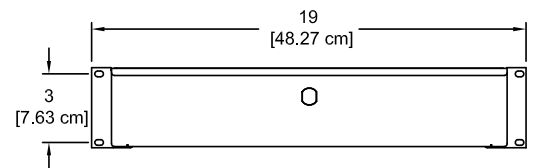
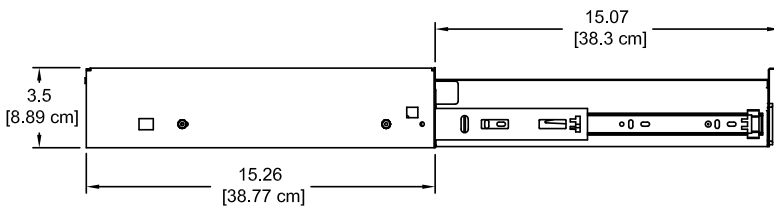
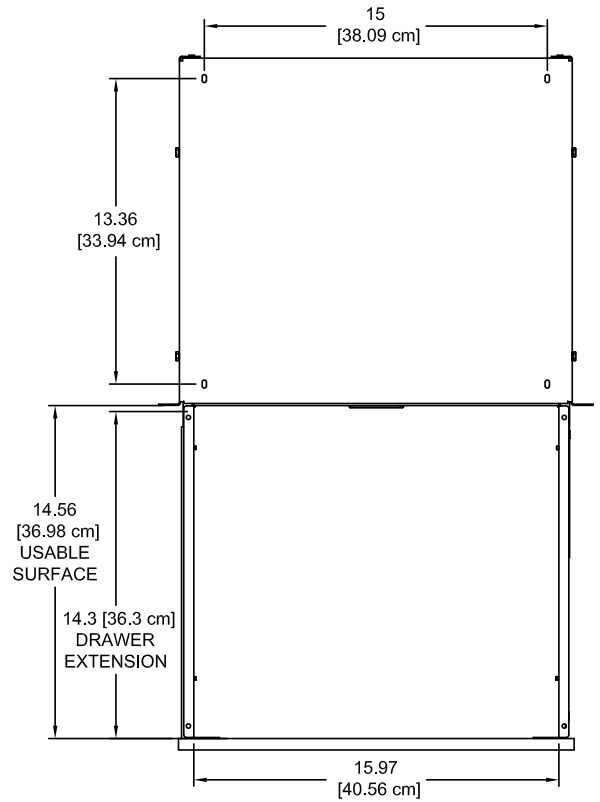

## Features and Benefits

- Full extension ball bearing slides extend a full 14"
- Mounts to standard rack rails
- Keylock and latch for security (*customer-installed*)
- 2" cable opening at back of drawer
- Durable powder coated steel chassis provides a long-lasting finish
- Made in Chippewa Falls, WI, USA

## Specifications

Weight Capacity	50 lb [22.7 kg]
Material	16 ga steel
Rack units required	2RU
Shipping weight (nominal)	15.85 lb [7.2 kg]

*Specifications subject to change without notice*

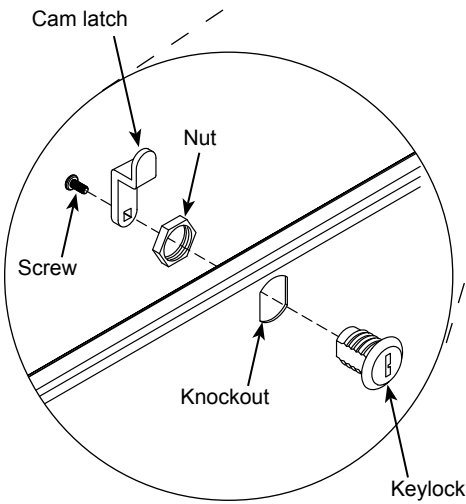
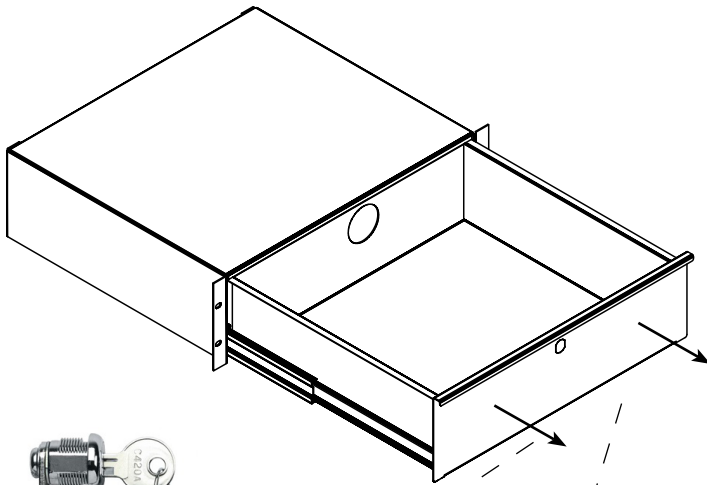

Keylock Assembly  
(customer-installed)

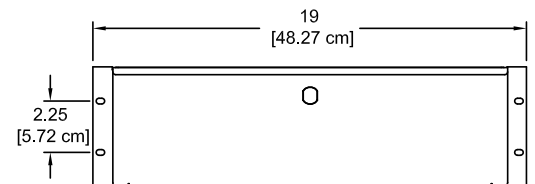
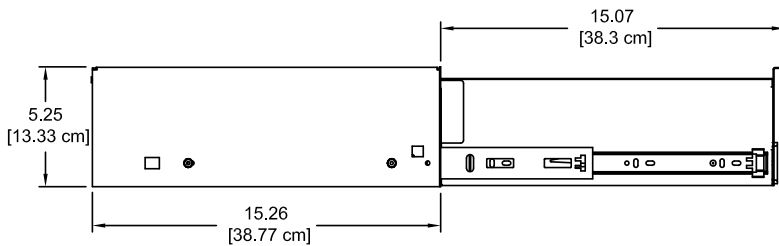
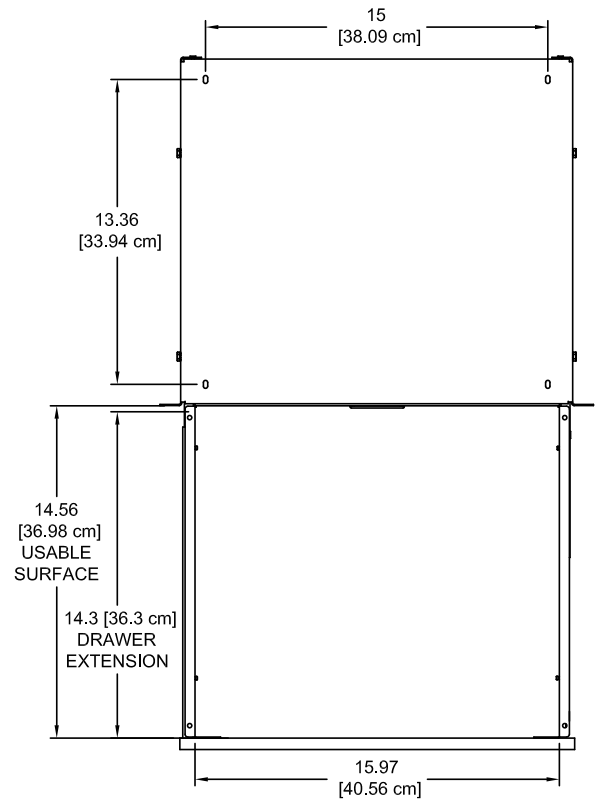

## Features and Benefits

- Full extension ball bearing slides extend a full 14"
- Mounts to standard rack rails
- Keylock and latch for security (*customer-installed*)
- 2" cable opening at back of drawer
- Durable powder coated steel chassis provides a long-lasting finish
- Made in Chippewa Falls, WI, USA

## Specifications

Weight Capacity	50 lb [22.7 kg]
Material	16 ga steel
Rack units required	3RU
Shipping weight (nominal)	18.5 lb [8.4 kg]

*Specifications subject to change without notice*

# LT-4 Laptop Storage Unit - 7RU

97517

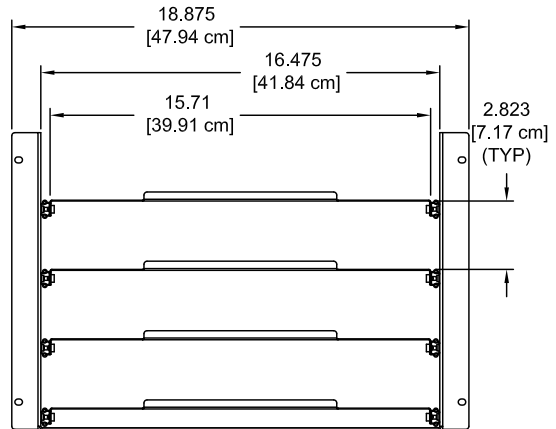
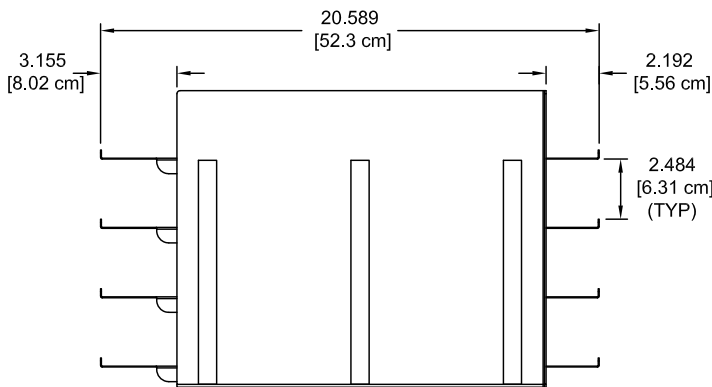
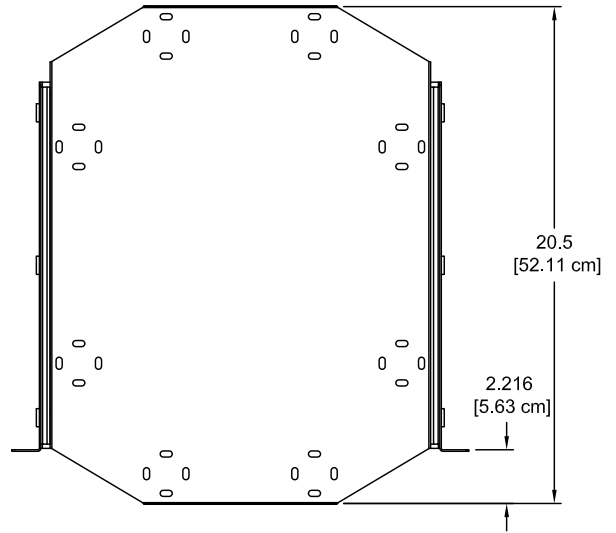
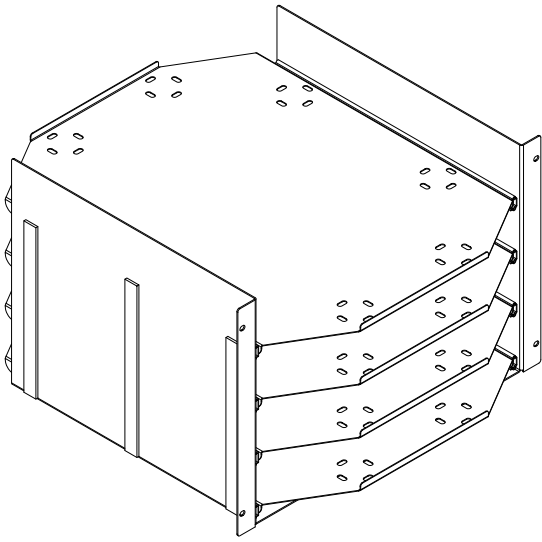

## Features and Benefits

- Stores 4 full-size laptops horizontally
- 4 laptop trays pull out from the front and rear, providing quick and easy access to laptops and cables
- Mounts to standard rack rails
- Velcro® straps and pads (for chargers) included
- Durable powder coated steel chassis provides a long-lasting finish
- Meets or exceeds applicable ANSI-BIFMA test standards
- Made in Chippewa Falls, WI, USA

## Construction

- Metal components consist of 16 and 20-gauge steel
- 20-gauge steel trays and side panels
- All metal components are finished with a scratch-resistant powder coat epoxy
- Factory-assembled

## Specifications

Capacity	4 full-size laptops
Pull out trays	<ul style="list-style-type: none"> <li>• 4 trays</li> <li>• Tray size: 16.475"W [41.8 cm] x 20.589"D [52 cm] x 2.823"H [7.2 cm]</li> <li>• Maximum recommended load per tray not to exceed 7 lb [3.18 kg]</li> </ul>
Material	16, and 20 ga steel
Rack units required	7RU
Shipping weight (nominal)	30 lb [13.6 kg]

*Specifications subject to change without notice*

Note: Power accommodations need to be made to provide laptop charging.



Laptop tray

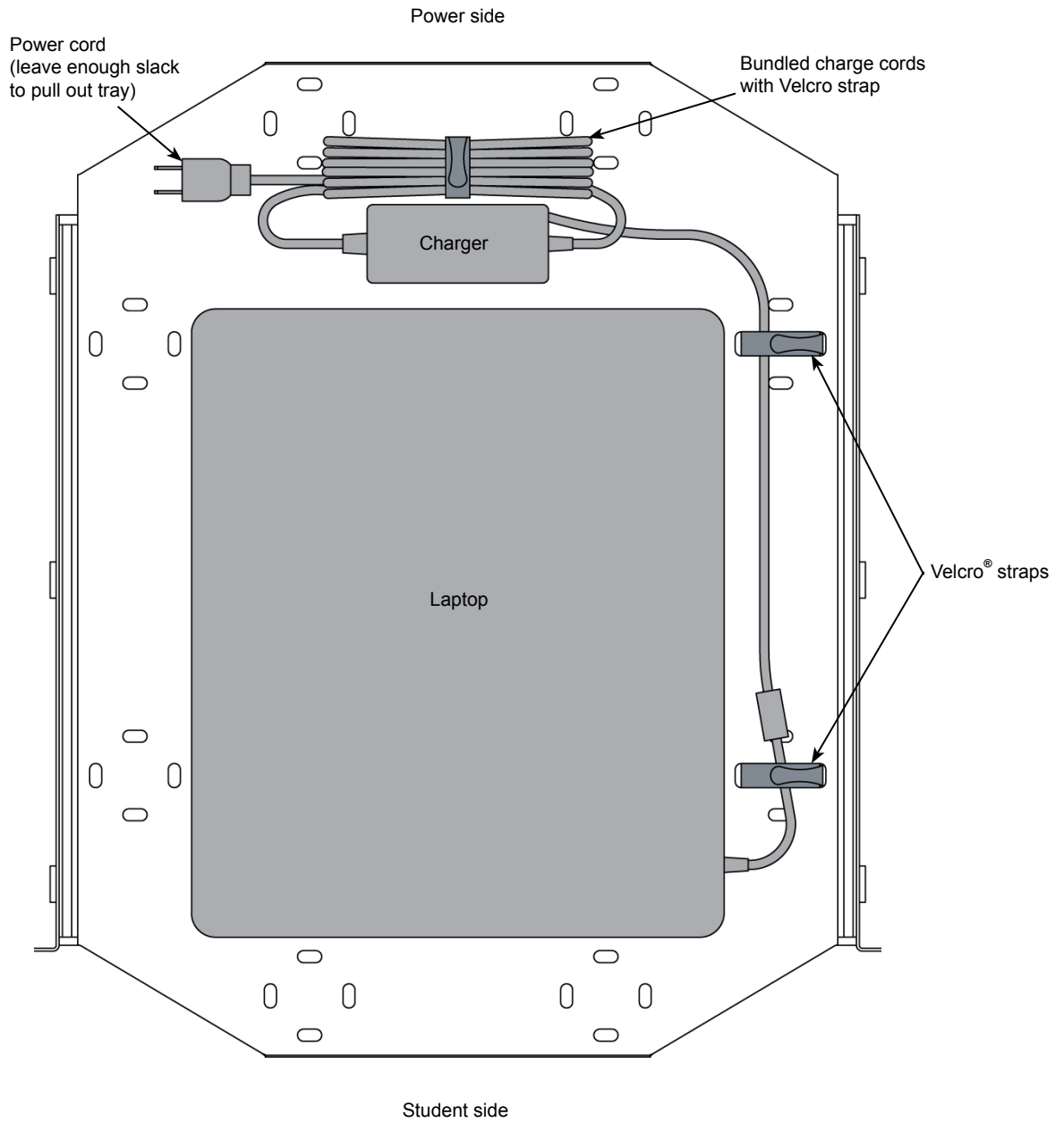

# Rack-mount Blanks

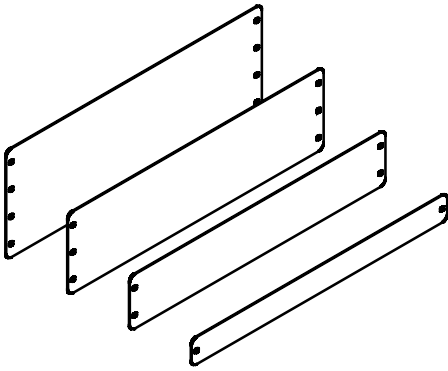

97510	1RU	97512	3RU
97511	2RU	97513	4RU

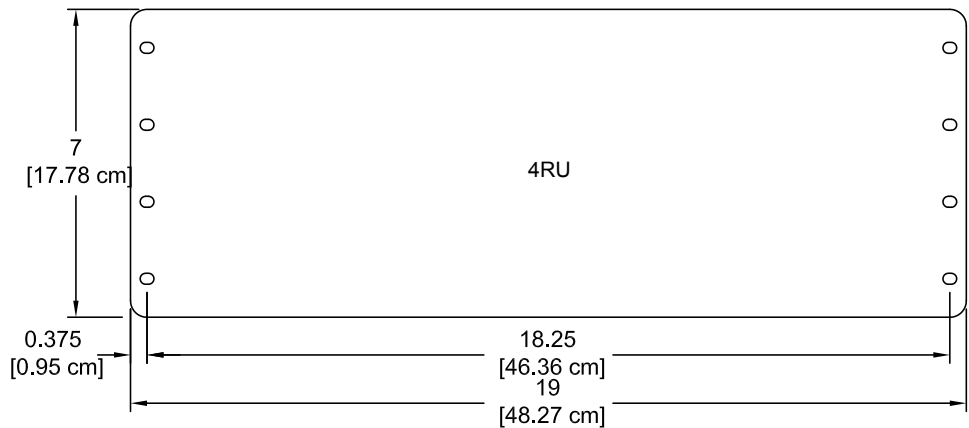
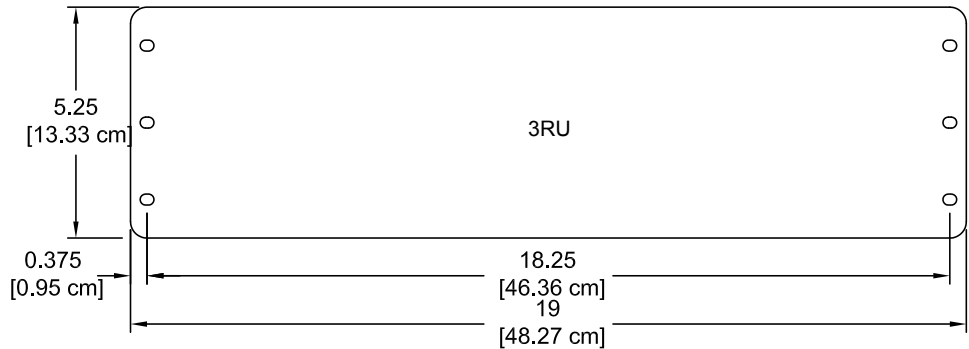
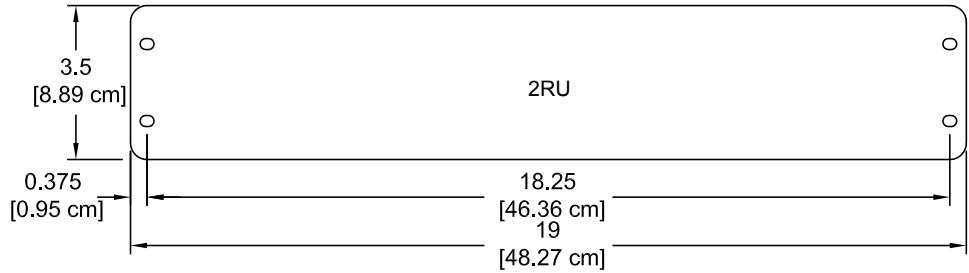
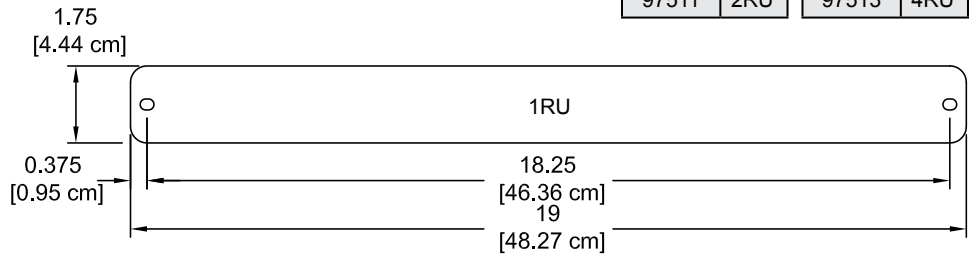

## Features and Benefits

- Fills rack spaces where components are not needed
- Durable powder coated steel provides a long-lasting finish
- Made in Chippewa Falls, WI, USA

## Specifications

Sizes available	1RU, 2RU, 3RU, 4RU
Material	16 ga steel
Shipping weight (nominal)	<1 lb [.45 kg]

*Specifications subject to change without notice*

## Cooling Fans - 3RU

97507	Single Fan
97506	Double Fan

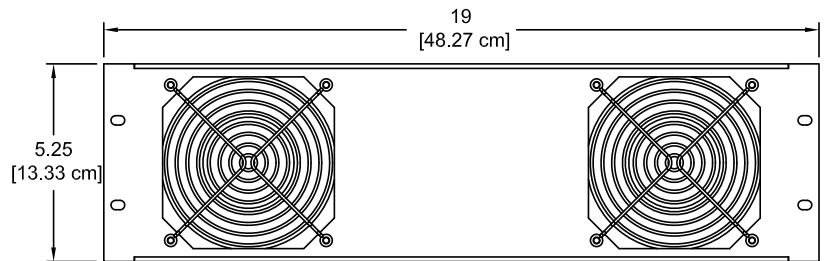
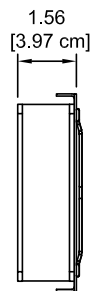
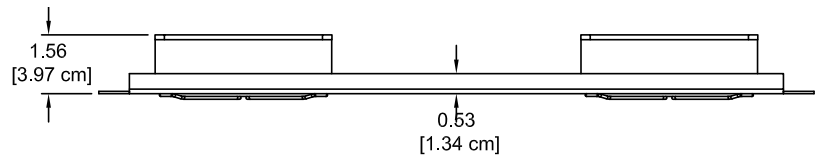
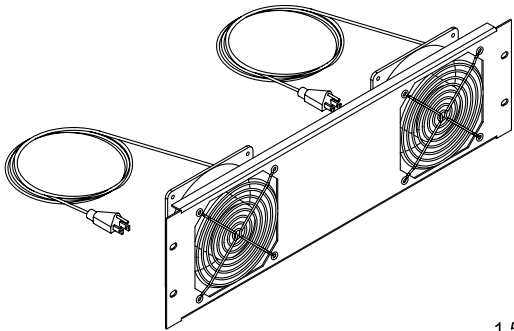
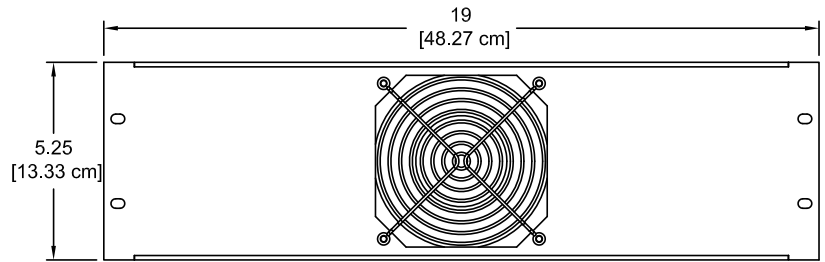
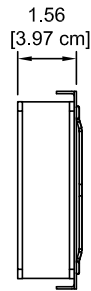
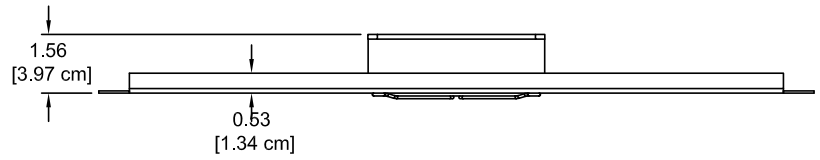
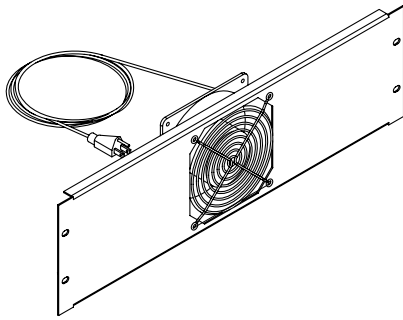

## Features and Benefits

- Provides cooling for rack-mount components
- Can be installed to provide air exhaust or air intake
- Quiet operation
- Durable powder coated steel provides a long-lasting finish

## Specifications

Capacity	50 CFM - Single Fan 100 CFM - Double Fan
Electrical	<ul style="list-style-type: none"> <li>• 120V~50/60 Hz, 15/13W</li> <li>• RoHS</li> <li>• Greenguard certified</li> </ul>
Rack units required	3RU
Shipping weight (nominal)	3.78 lb [1.7 kg] - Single Fan - 97507 5.47 lb [2.5 kg] - Double Fan - 97506

*Specifications subject to change without notice*

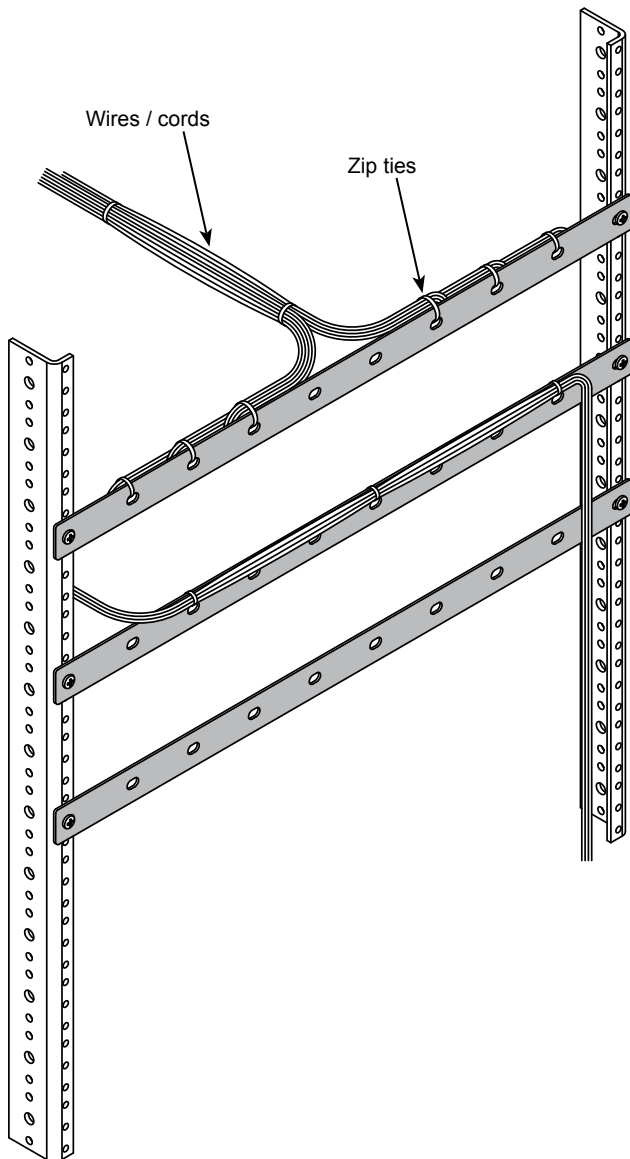

## Features and Benefits

- Provides wire management for rack-mount component wiring
- 3 lace straps and mounting screws included
- (12) 5.5" zip ties included
- Mounts to standard rack rails
- Durable powder coated steel provides a long-lasting finish
- Made in Chippewa Falls, WI, USA
- Shipping weight (nominal): 1.25 lb [.57kg]

# 9-Outlet Power Strip - 1RU

99021

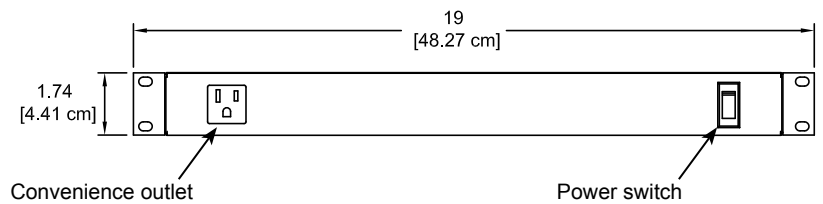
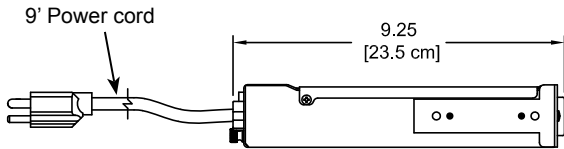
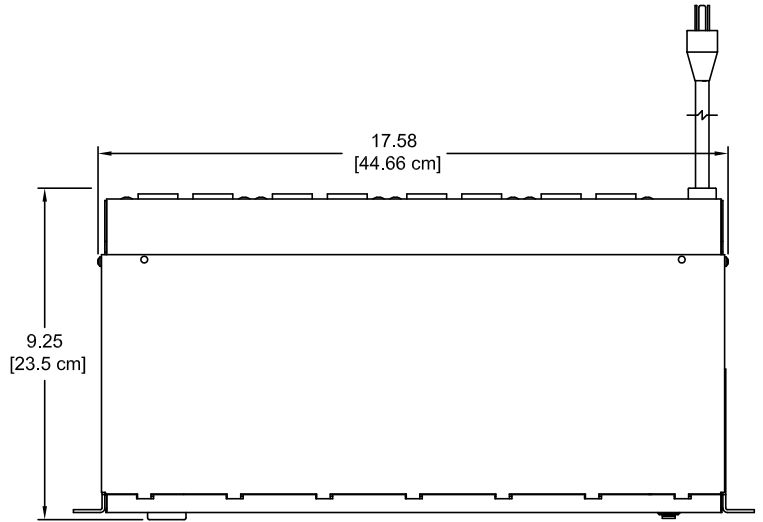
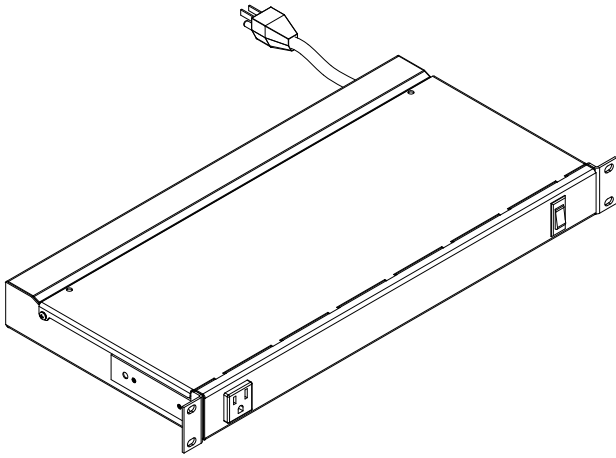

Rear View

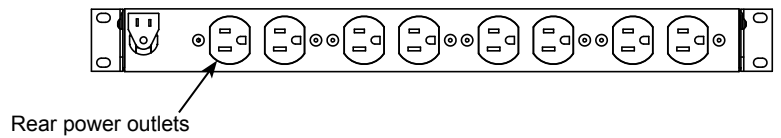

## Features and Benefits

- 8 outlets at rear
- 1 convenience outlet at front
- LED power switch on front
- Mounts to standard rack rails
- Durable powder coated steel provides a long-lasting finish
- UL listed

## Specifications

Outlets	<ul style="list-style-type: none"> <li>• 8 outlets rear (breaker-protected)</li> <li>• 1 convenience outlet front</li> </ul>
Electrical	<ul style="list-style-type: none"> <li>• 115VAC, 60Hz</li> <li>• 15 amps max</li> <li>• 9' Power cord length</li> <li>• Front LED power switch</li> <li>• Enhanced surge protection</li> <li>• ETL listed, UL listed</li> </ul>
Rack units required	1RU
Shipping weight (nominal)	8.7 lb [3.9 kg]

Specifications subject to change without notice



## Warranty

### We will make it right for you!

Thanks for choosing Spectrum! Spectrum is committed to provide complete customer satisfaction. Each of our products is manufactured from the best materials available and each product is stringently monitored throughout the production process through our P.A.C.E. program (Product Assurance to meet Customer Expectations).

We expressly warrant that Spectrum products will be of good quality and workmanship and free from defect for the period set out in the warranty from the date of delivery.

**For a listing of all product specific warranty terms please visit our website at:**

<https://www.spectrumfurniture.com/en/resources/purchasing-terms-warranty>

**1-800-235-1262**

Toll-free HELPLINE

**[spectrum@spectrumfurniture.com](mailto:spectrum@spectrumfurniture.com)**



Spectrum Industries is Certified ISO 9001:2015