

Technical Specifications

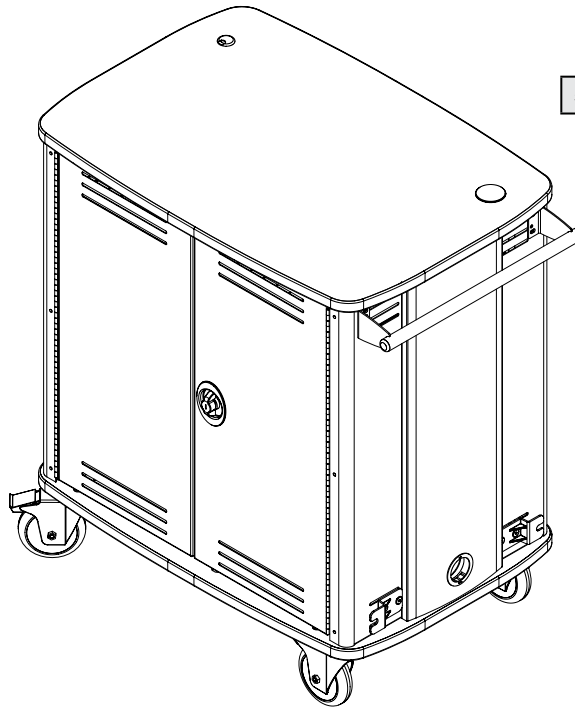

InTouch 40 Tablet / Chromebook Cart

55441 with two 120V power units & cord wraps

InTouch 20 Tablet / Chromebook Cart

55446 with one 120V power unit & cord wraps

Spectrum's InTouch line of carts are designed to store, transport, and recharge up to 20 or 40 tablet, e-readers, iPad®, and/or Chromebook-style computers. Each cart can also be outfitted with optional USB hubs easily installed in the field if device synchronization or imaging is necessary. The cart stores up to 20 or 40 devices up to 1.25" thick in individual vertical compartments with soft plastic dividers. Simple cord management trays store all line voltage charging devices safely away from students, and allow the low voltage charge cables to hang directly above each computer for easy student access. The teachers laptop and accessories easily store in a fixed shelf directly above student tablets or Chromebooks.

Features and Benefits

- Storage and charging for up to 20, or 40 tablet or Chromebook computers (up to 1.25" thick) with easy-access to electrical power
- Ample clearance is provided for easy removal / insertion of devices
- Durable powder coated steel chassis
- Scratch and impact-resistant 1.063" high-pressure laminate worksurface
- Two directional, swivel locking 5" balloon wheels can be rotated and locked at 180° intervals for steering purposes and make the unit extremely mobile for easy transport between classrooms
- Pull-out trays keep cords and charge blocks organized
- Numbered storage bays keep computers organized
- All line voltage wiring is accessible through locking instructor-side door. Students have access to computers and USB / low voltage only through locking student side doors
- Doors and side panels are effectively ventilated to keep tablets and chargers cool
- Durable plastic dividers protect computers from damage
- Storage area at top of cart provides space for a laptop or other items
- Cord management system keeps charge cords organized at each storage slot
- 20 outlet, 120V, power unit(s) with 15-amp breaker and reset button (two on InTouch 40, one on InTouch 20)
- Electrical system consists of UL-listed components
- External cord management brackets keeps power cord organized
- Cable grommets strategically placed throughout for effective cord management
- One standard handle provides control and mobility
- Optional pull-out instructor tray provides storage for laptop or other peripherals
- Warranted to be free of all defects in materials and workmanship with a 10-year warranty

Capacity

40 or 20 tablets or Chromebooks

Base

DW - 5" balloon wheels
(2 swivel, 2 swivel directional locking)

Options

Page 12

Color Options

Standard laminate / color combinations

White Fiesta / Cool White
(WFCW)

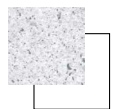

Standard color combination refers to the quickest deliverable product color combination. Custom laminates and color combinations are available-additional lead-times and up-charges may apply. Call 1-800-235-1262 for further information.

Construction

- The worksurface and base panel is constructed from 1.063" thick NAUF (no added urea formaldehyde) composite board with .030" high-pressure laminate on one face, and a balancing phenolic backer on the opposing face
- 16-gauge steel side panels, doors, and shelves
- Worksurface edges are covered with 3mm vinyl
- All metal components are finished with a scratch-resistant powder coat epoxy
- Each InTouch Cart is factory-assembled, packaged, and shipped on its own skid.
(Handle to be installed by customer).

Note: The cord management trays are factory-installed in the lower position to provide additional clearance for chargers and cords. In this position, the trays will accommodate most brick-style Chromebook chargers on the market.

The trays can easily be moved to the upper position to provide an additional .4375" of height to the tablet devices below if needed.

Specifications

Capacity	40 tablets or Chromebooks - InTouch 40 20 tablets or Chromebooks - InTouch 20	
Storage bays (nominal)	1.25"W x 12.125"D x	9.5625"H <i>cord tray in upper position</i> 9.125"H <i>cord tray in lower position (factory-installed)</i>
Cord management tray(s) (nominal)	26.25"W x 15.375"D x	.875"H <i>cord tray in upper position</i> 1.3125"H <i>cord tray in lower position (factory-installed)</i>
Instructor storage area	28.375"W x 13.25"D x 4.5"H	
5" Balloon Wheels	weight capacity 325 lbs each	
Electrical	<ul style="list-style-type: none"> • 20 outlet power unit(s) (2) - InTouch 40, (1) - InTouch 20 • 125V~/12A, 60Hz • 15-amp breaker • on/off switch 	<ul style="list-style-type: none"> • a separate wall circuit is recommended for each power unit • 15' nominal 14 AWG, 3-wire power cord • locking power side door isolates and separates electrical line voltage from students • UL listed components
<p>Note: The customer should be aware of the amp draw of the devices used with this cart-especially when maxing out the storage and charging capacity. Exceeding 15 amps per 20 outlet power unit will trip the circuit breaker. Please consult the owners manual of your specific device for power consumption information.</p>		
Unit weights (nominal)	216 lbs - InTouch 40 184 lbs - InTouch 20	
Shipping weights (nominal)	258 lbs - InTouch 40 223 lbs - InTouch 20	

Meets or exceeds applicable ANSI-BIFMA test standards

Specifications subject to change without notice

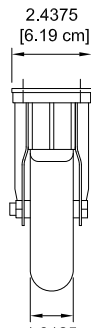
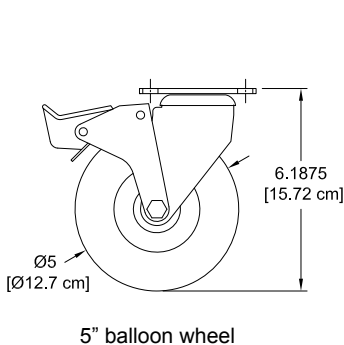

InTouch 40 - 4 factory-installed cord wraps included
InTouch 20 - 2 factory-installed cord wraps included

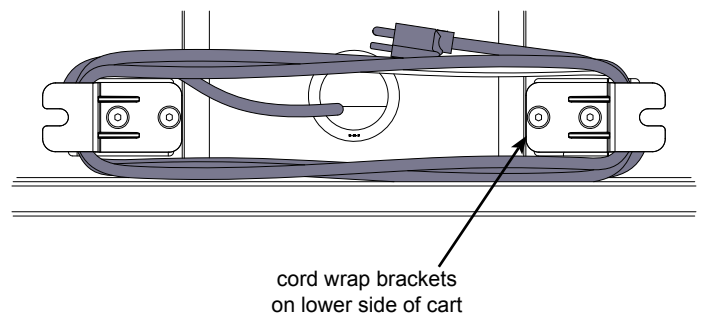

Note: Two swivel directional locking 5" balloon wheels can be rotated and locked at 180° intervals to be rigid, or unlocked to be swivel, and allow the unit to be extremely mobile for easy transport between classrooms.

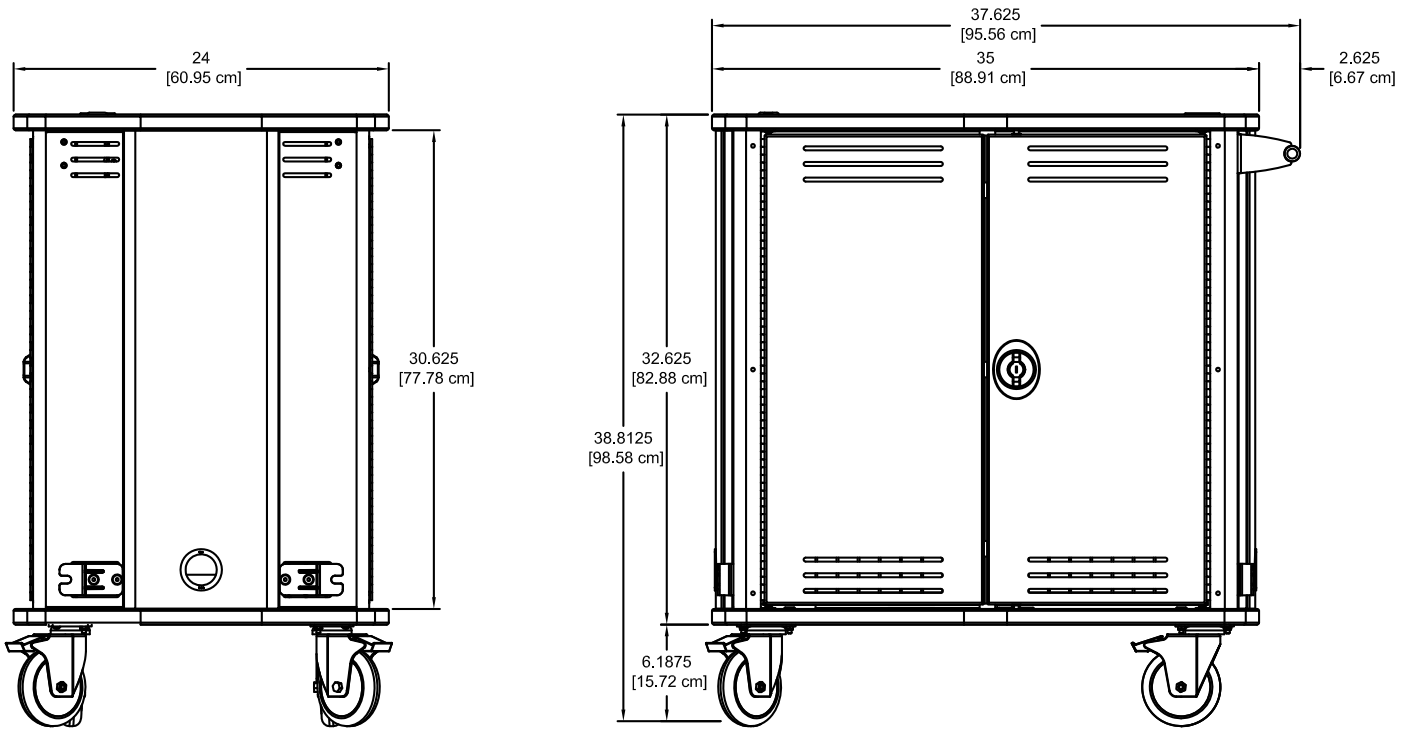
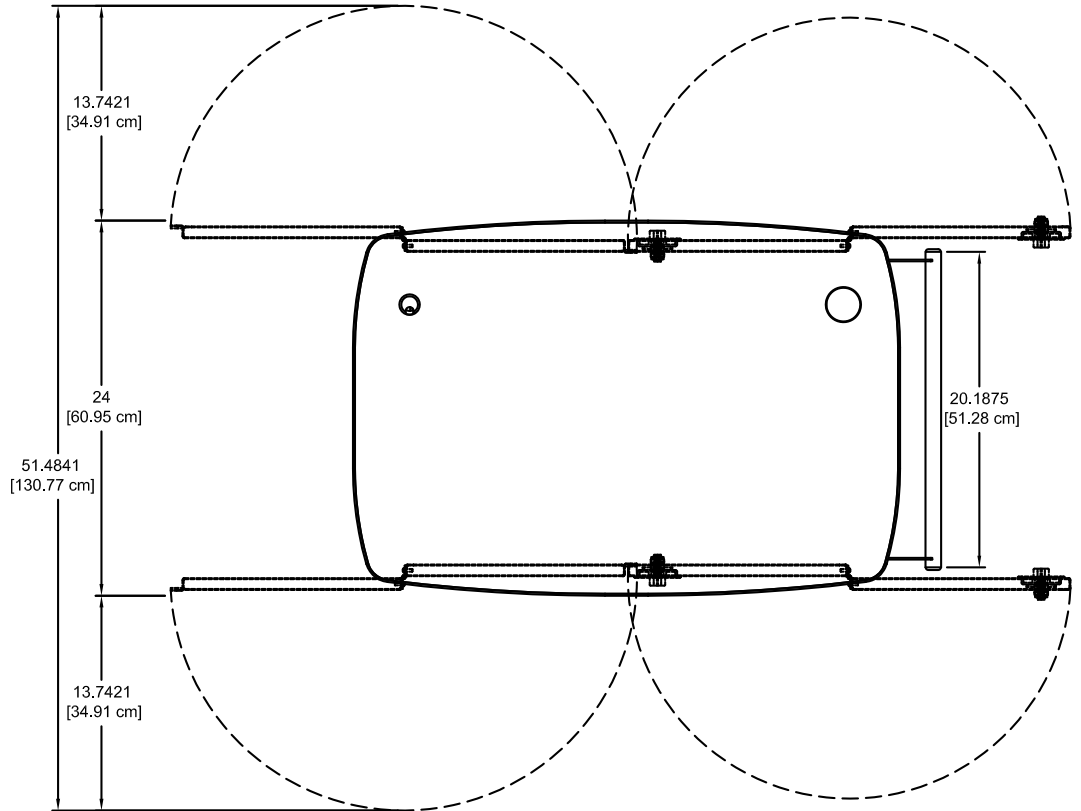

InTouch 40 Tablet Cart

Cord management trays

The trays can easily be moved to the upper position to provide an additional .4375" of height to the tablet devices below if needed.

The trays are factory-installed in the lower position to provide additional clearance for chargers and cords in the tray. In this position, the trays accommodate most brick-style Chromebook chargers on the market.

Upper tray position: .875" charger height available
9.5625" device-height available

Lower tray position: 1.3125" charger height available
(factory-installed) 9.125" device-height available

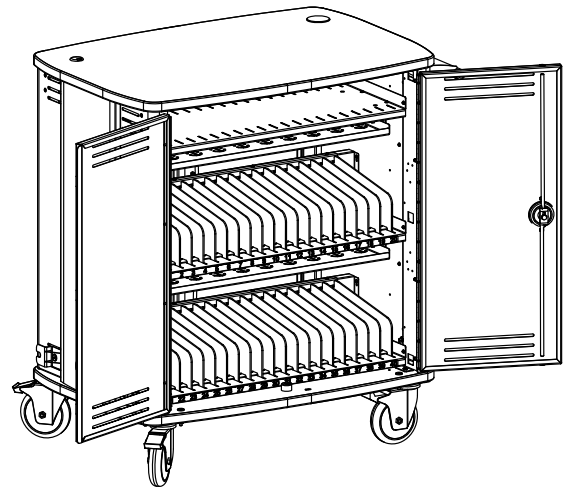

student side view
(shown with doors removed)

handle can be mounted on either side

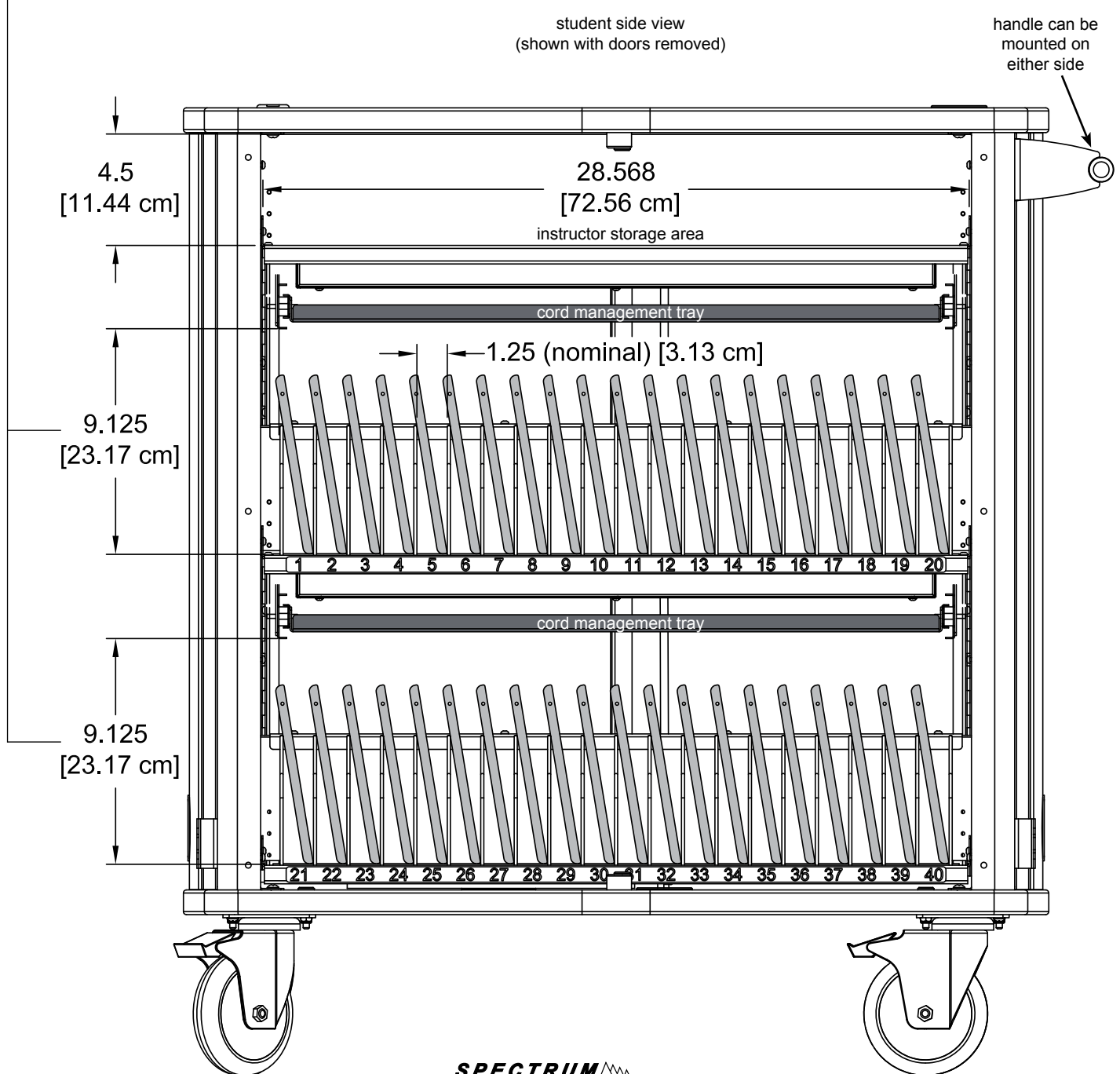

outlet spacing on each
20 outlet power unit

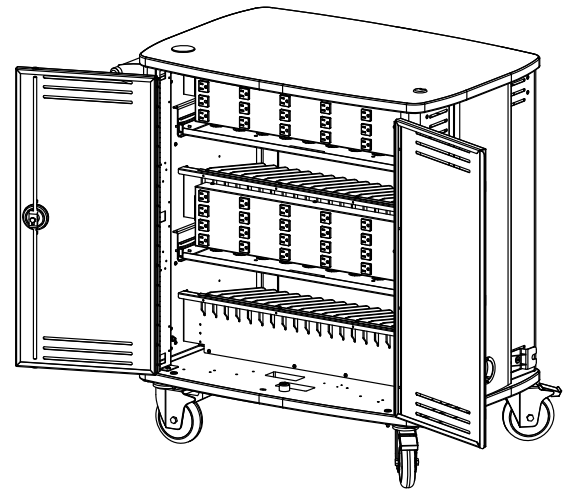
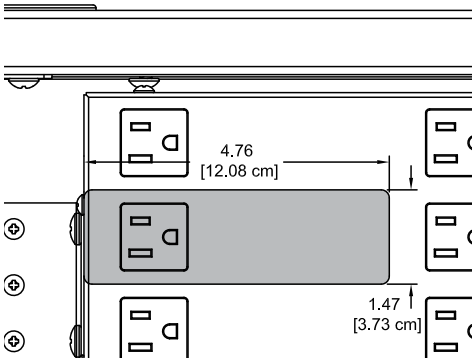

power side view
(shown with doors removed)

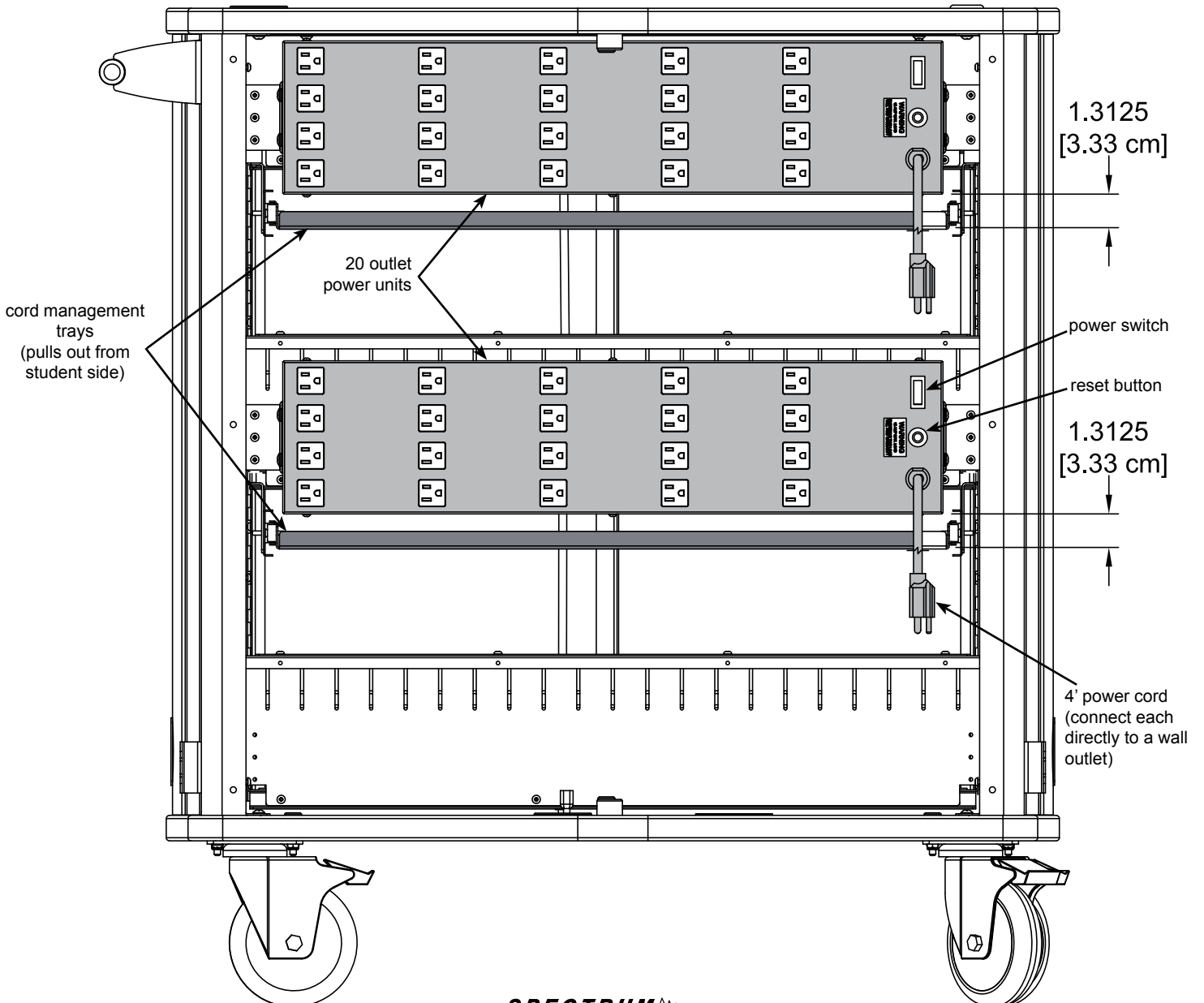

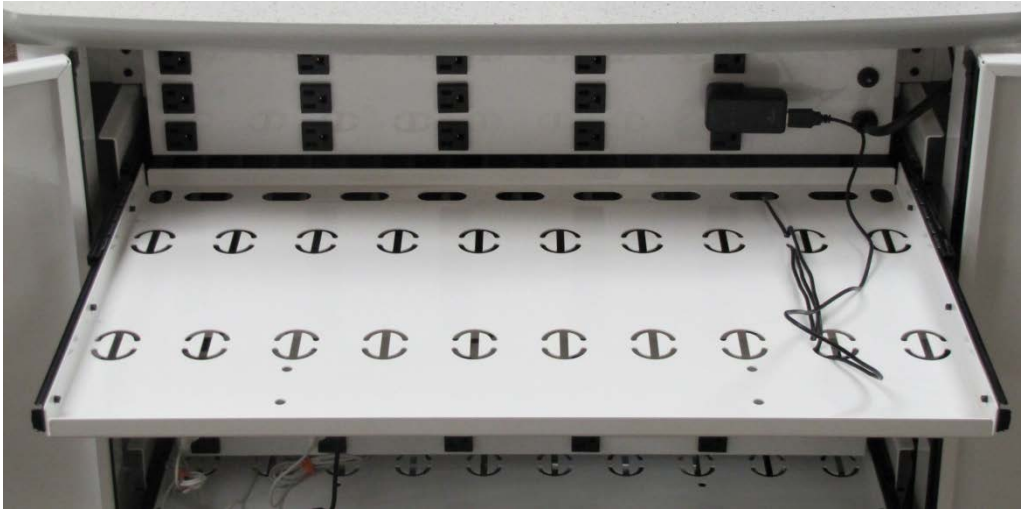

cord management tray

side view
(shown with doors removed)

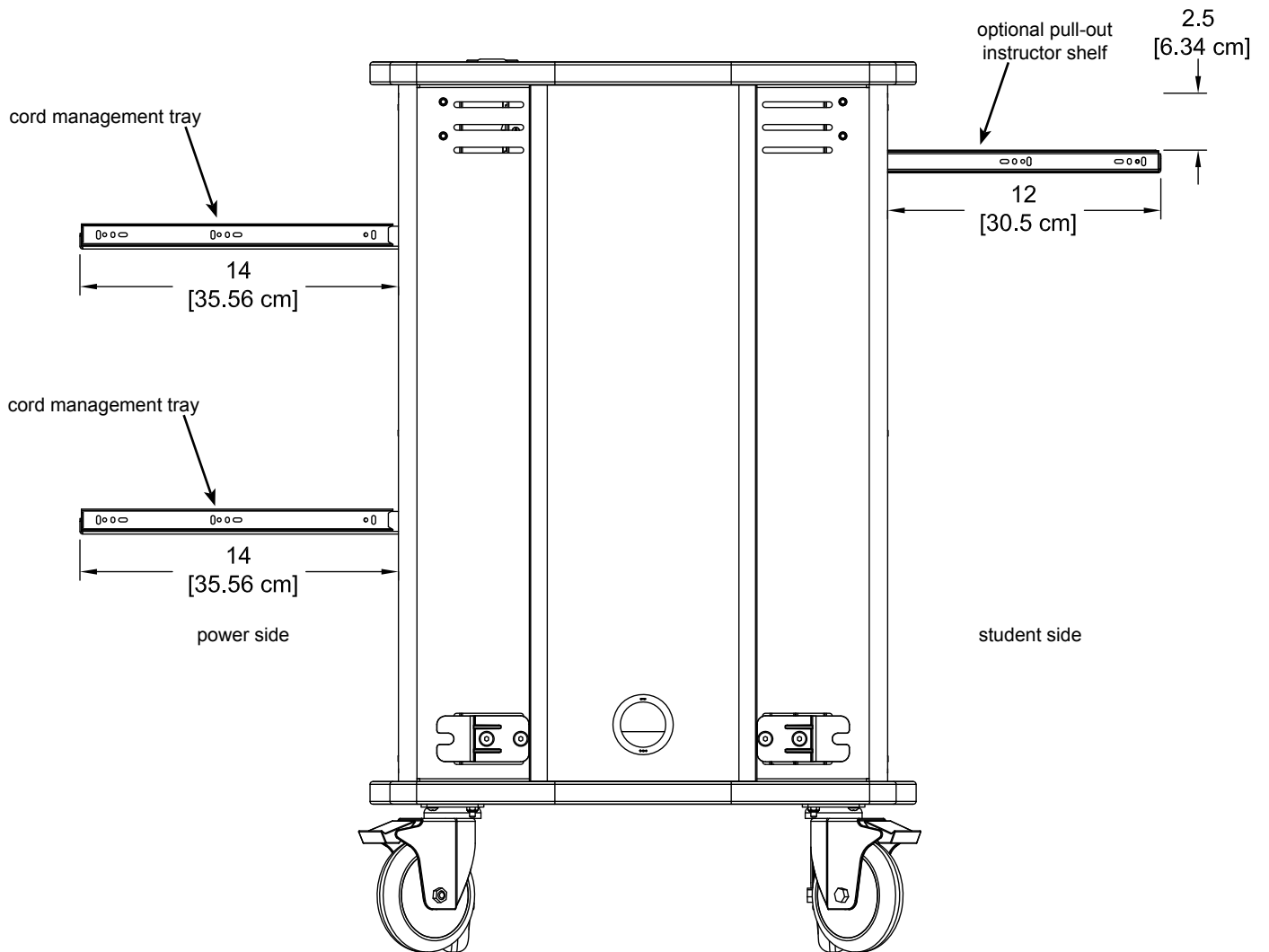

InTouch 40 Cart
section view

Cord management trays

The trays can easily be moved to the upper position to provide an additional .4375" of height to the tablet devices below if needed.

The trays are factory-installed in the lower position to provide additional clearance for chargers and cords in the tray. In this position, the trays accommodate most brick-style Chromebook chargers on the market.

Upper tray position: .875" charger height available
9.5625" device-height available

Lower tray position: 1.3125" charger height available
(factory-installed) 9.125" device-height available

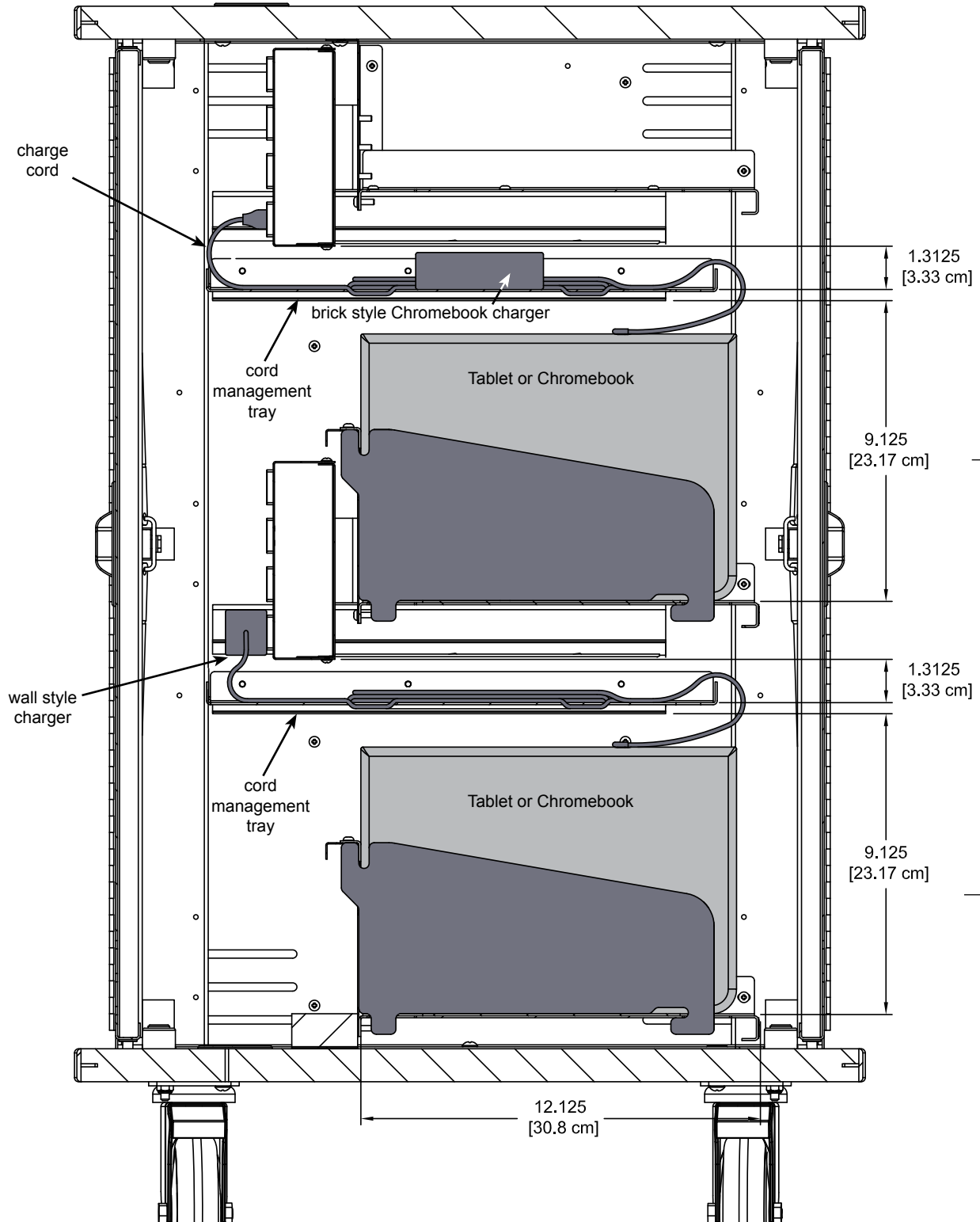

InTouch 20 Tablet Cart

Cord management trays

The trays can easily be moved to the upper position to provide an additional .4375" of height to the tablet devices below if needed.

The trays are factory-installed in the lower position to provide additional clearance for chargers and cords in the tray. In this position, the trays accommodate most brick-style Chromebook chargers on the market.

Upper tray position: .875" charger height available
9.5625" device-height available

Lower tray position: 1.3125" charger height available
(factory-installed) 9.125" device-height available

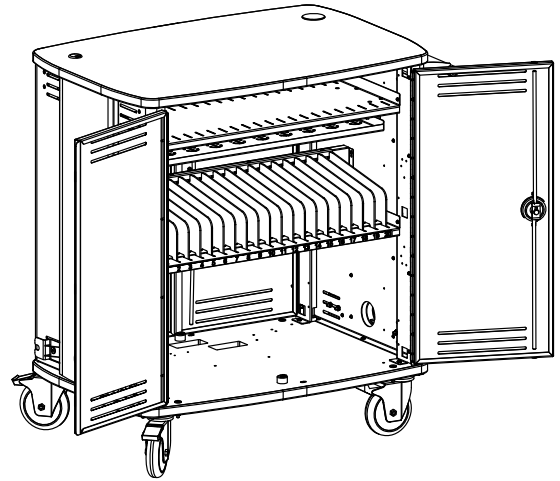

student side view
(shown with doors removed)

handle can be
mounted on
either side

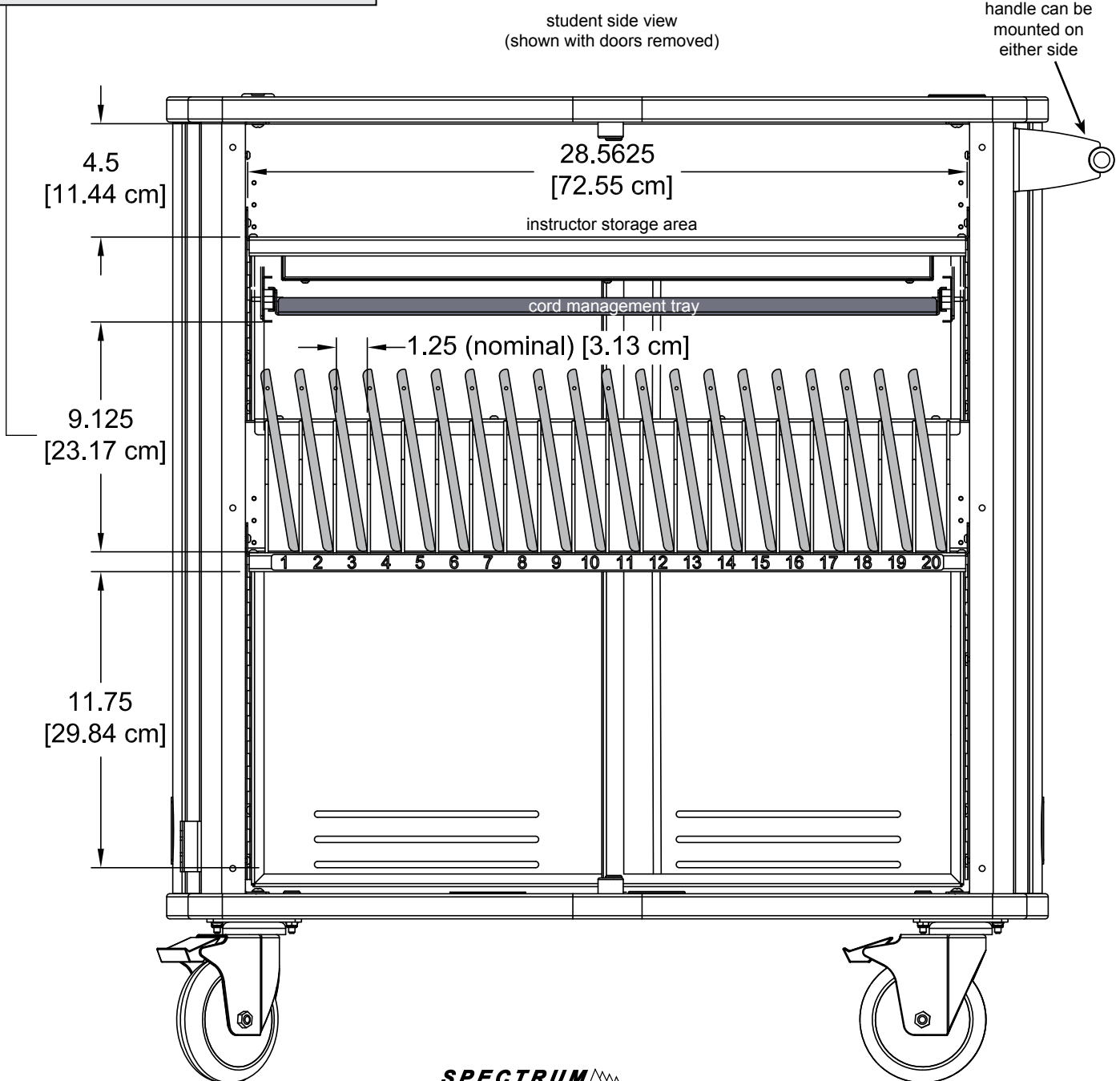

outlet spacing on each
20 outlet power unit

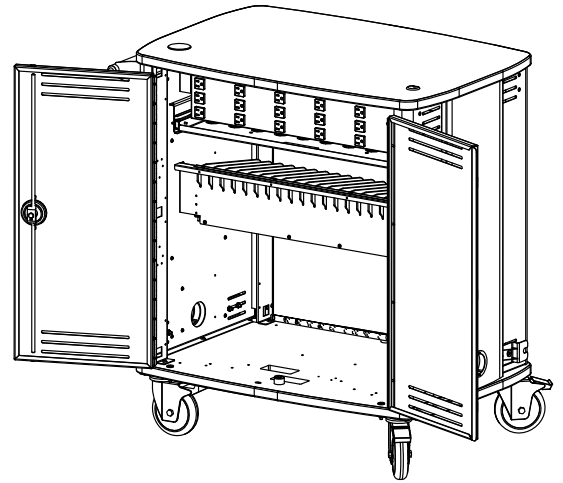
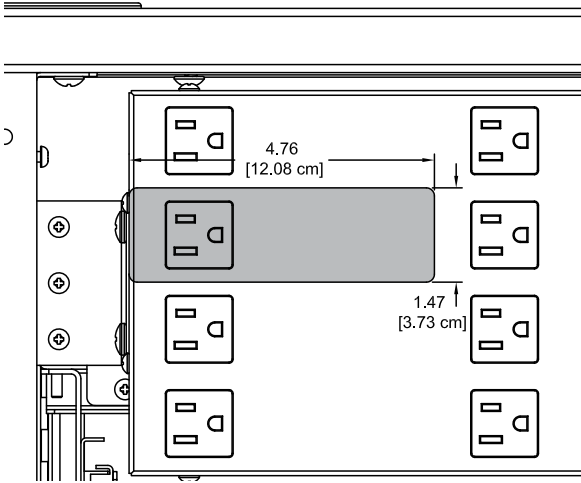

power side view
(shown with doors removed)

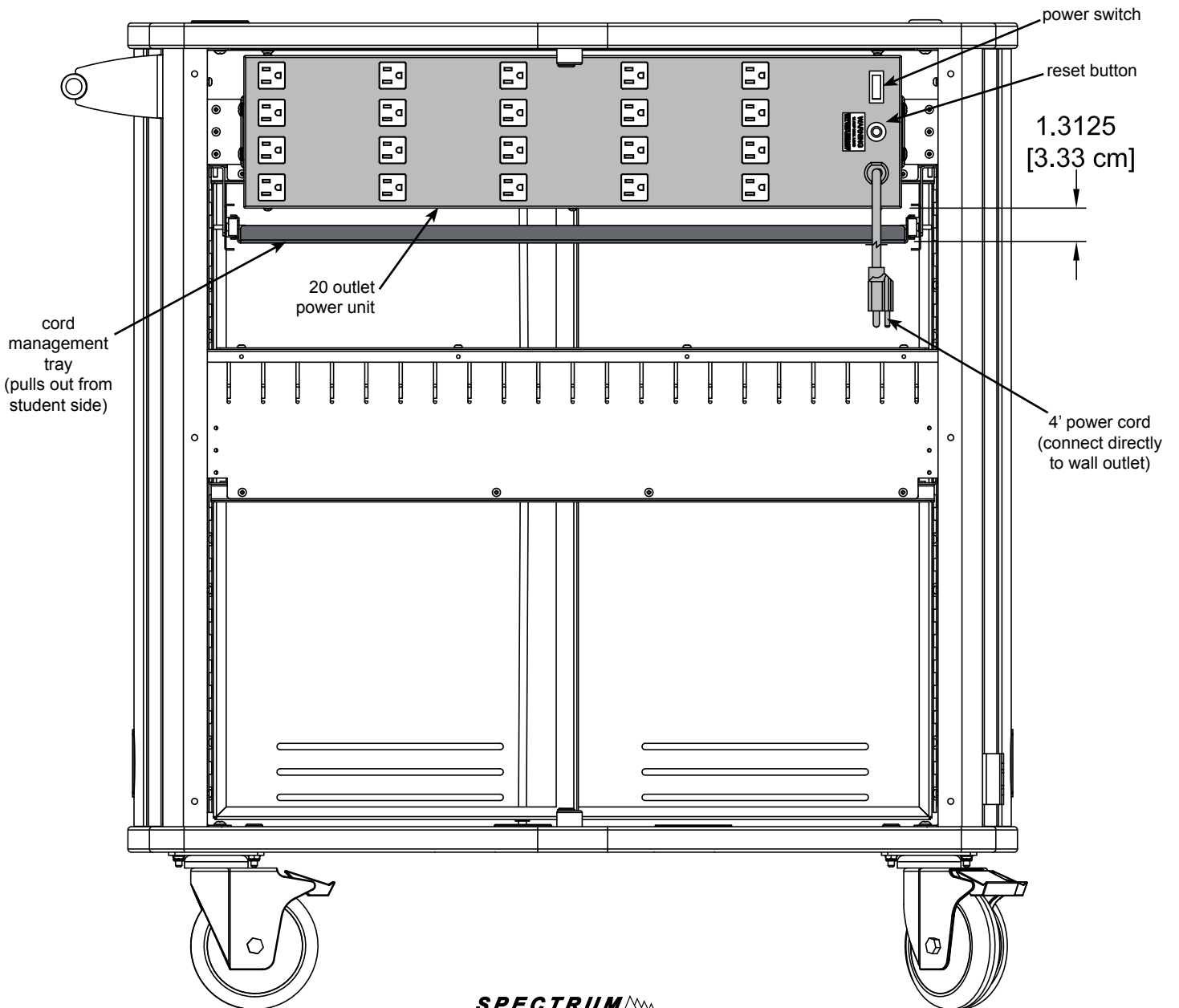

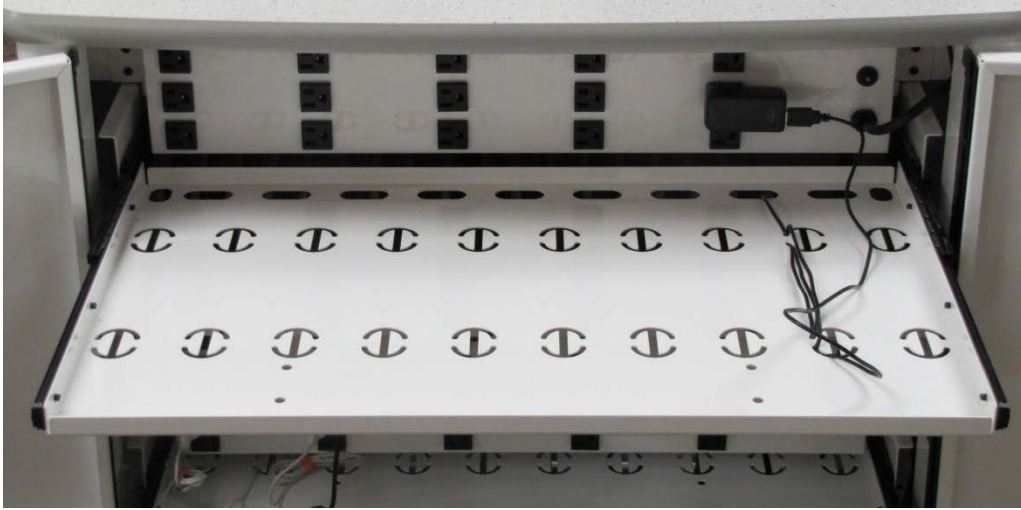

cord management tray

side view
(shown with doors removed)

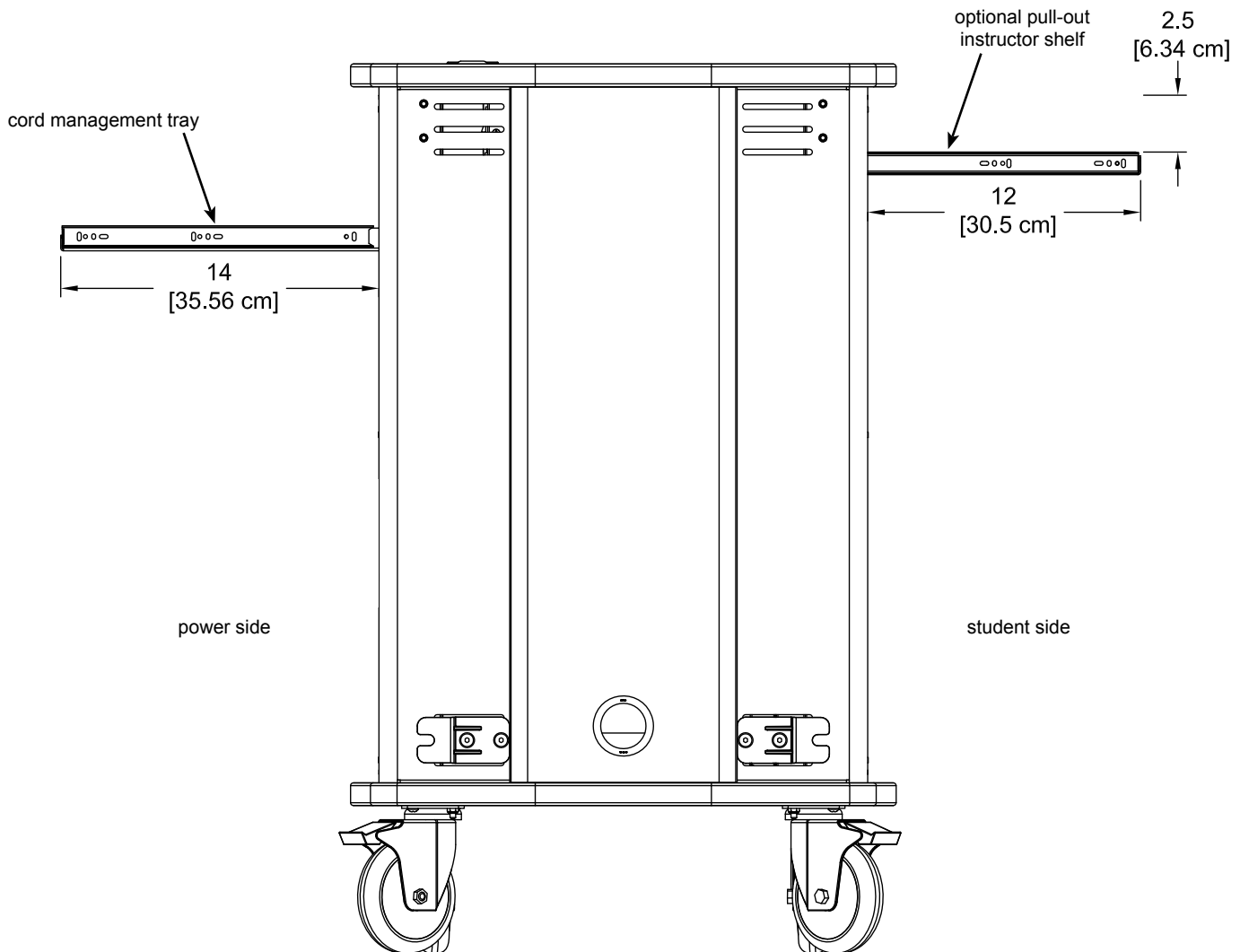

InTouch 20 Cart
section view

Cord management trays

The trays can easily be moved to the upper position to provide an additional .4375" of height to the tablet devices below if needed.

The trays are factory-installed in the lower position to provide additional clearance for chargers and cords in the tray. In this position, the trays accommodate most brick-style Chromebook chargers on the market.

Upper tray position: .875" charger height available
9.5625" device-height available

Lower tray position: 1.3125" charger height available
(factory-installed) 9.125" device-height available

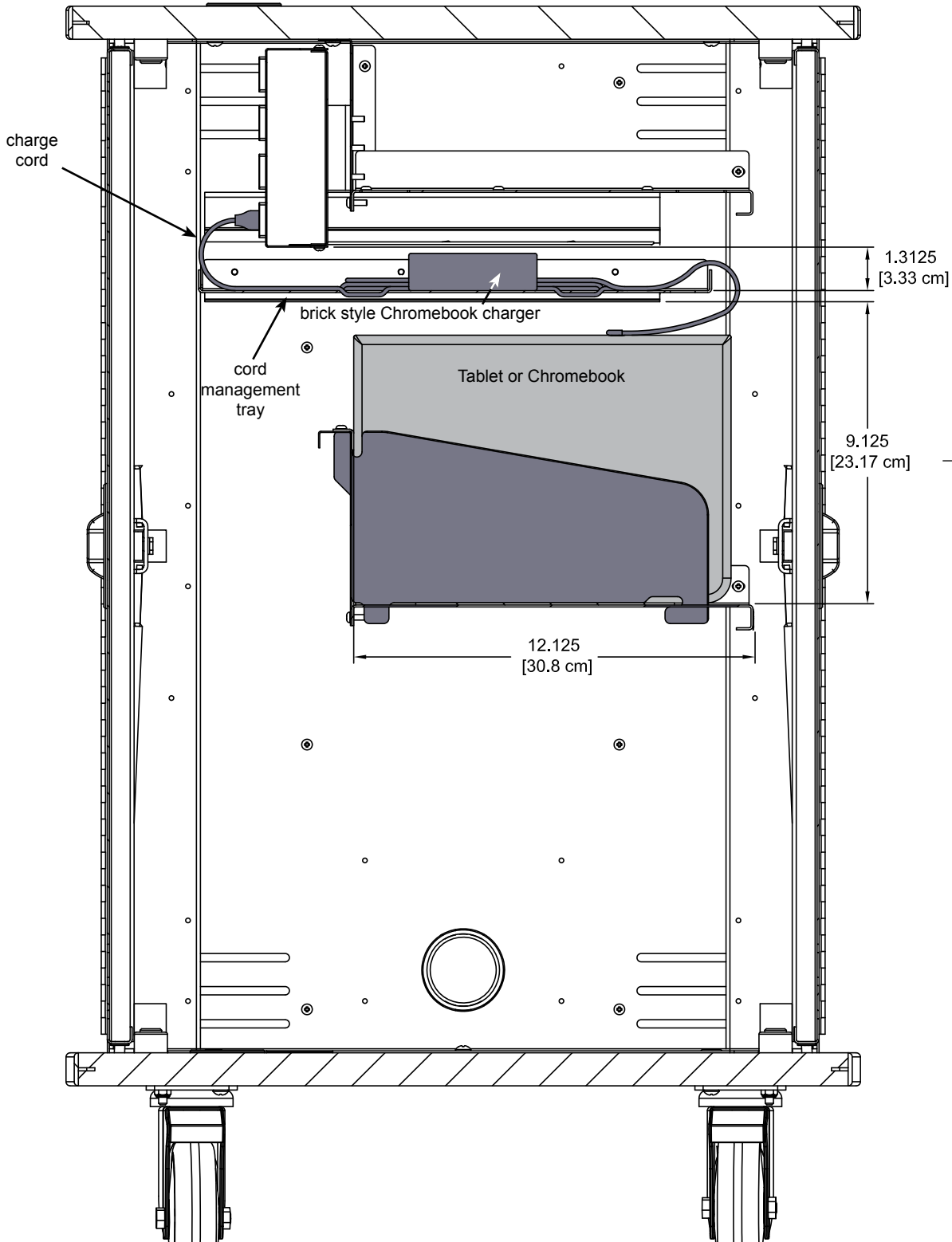

Options

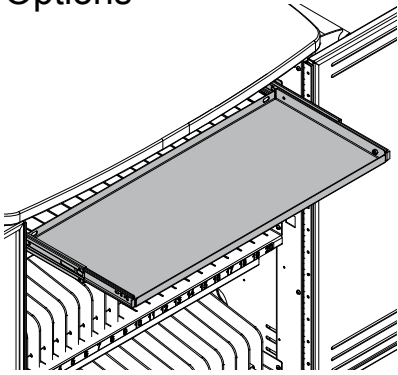

Pull-out tray
 (for instructor laptop or storage)
 25.4375"W x 11.375"D x 2.875"H
 (available height)
 55442

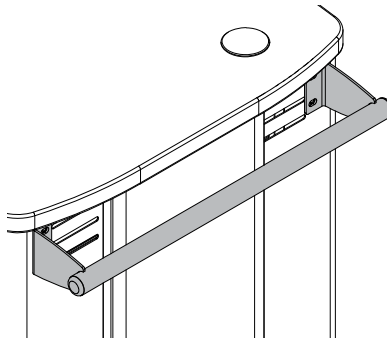

Additional steel handle
 (mounts on left or right, max 2 per unit)
 20.1875"W
 55393

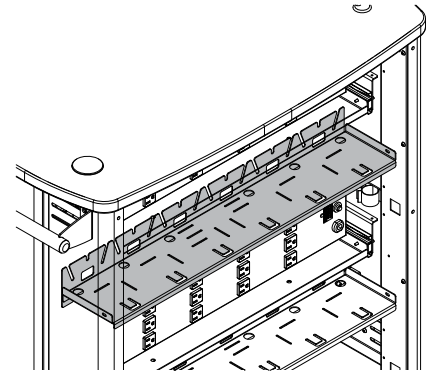

Storage shelf for USB hubs
 shelf only, hubs not included
 28.4375"W x 5"D
 55443

Includes:

- (1) shelf for mounting hubs (28.7375"W x 5"D)
- (1) cord wrap bracket
- (1) 7-outlet power strip with 12' cord
- (8) 3" x 2" Velcro® strips
- (15) zip ties

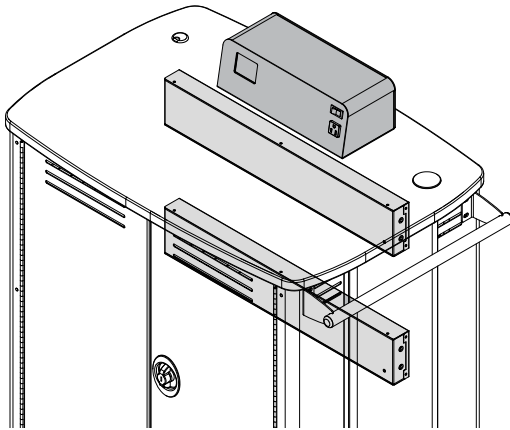

Sync/charge retrofit kit

Adds syncing & charging capability to existing InTouch 20 & 40 carts using a single USB cable to each tablet, eliminating the need for onboard tablet AC adapters. The metal is finished in Cool White powder coat.

Designed specifically for iPads, the InTouch Sync/Charge system uses an electronic touchscreen sync/charge power unit to provide synchronization and charging through a single USB cable.

55458 - 40 unit (includes 1 sync/charge unit & 2 USB power units) (28 lbs)

55459 - 20 unit (includes 1 sync/charge unit & 1 USB power unit) (23 lbs)

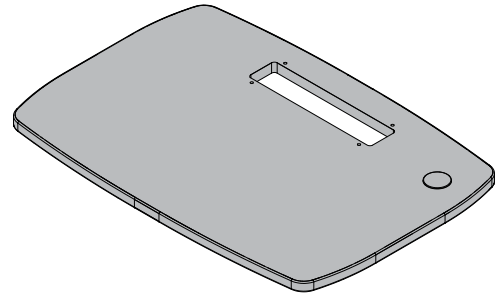

Sync/charge worksurface retrofit kit

Worksurface includes precut sync/charge unit cutout. White Fiesta laminate with Platinum edge band to match existing InTouch carts. (30 lbs)

55457

(must also order 55458 or 55459)

Note:

- The 55458 and 55459 Sync/charge retrofit kit requires the customer to make the sync/charge unit cutout in their existing InTouch cart worksurface with a jigsaw or router. The existing outlet power unit(s) also need to be swapped with the USB units included in this kit.
- The 55457 worksurface retrofit kit includes the worksurface with the sync/charge cutout needed for the Sync/charge retrofit kit. This new worksurface must be swapped with the existing InTouch worksurface.

Both of these options have a moderate difficulty rating to install, so experience and skill with tools is required.

Optional Syncing USB Hubs

Shelf with 7 Synchronizing USB Hubs 55444
(for InTouch 40 Carts)

Includes:

- (7) 7-port USB hubs with cables
- (1) shelf for mounting hubs (28.4375"W x 5"D)
- (1) cord wrap bracket
- (1) 7-outlet power strip with 12' cord
- (8) 3" x 2" Velcro® strips
- (15) zip ties

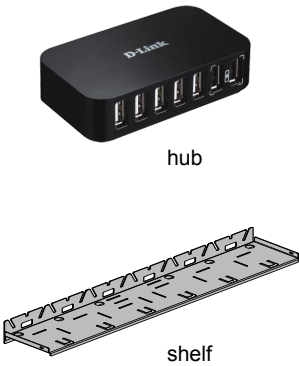

Shelf with 4 Synchronizing USB Hubs 55449
(for InTouch 20 Carts)

Includes:

- (4) 7-port USB hubs with cables
- (1) shelf for mounting hubs (28.4375"W x 5"D)
- (1) cord wrap bracket
- (1) 7-outlet power strip with 12' cord
- (8) 3" x 2" Velcro® strips
- (15) zip ties

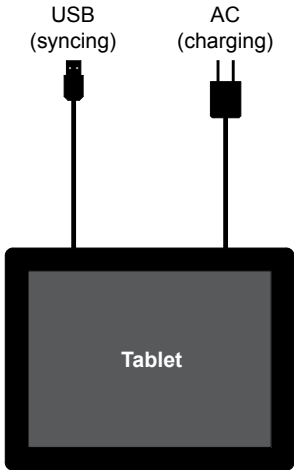

- Allows user/instructor laptop to synchronize tablet databases
- Utilizes industry standard hubs (USB 2.0/1.1/1.0) with data transfer up to 480 Mbps
- Includes diagnostic LEDs on hubs
- Hubs include Velcro® fasteners to attach to powder coated steel shelf
- Best value option that provides the ability to charge and synchronize
- Can be used with iPad® tablets by plugging the USB cable into the AC power adapter (for charging) or USB hub port (for syncing) when needed (see below)

Note: The optional USB hubs are for syncing only and do not provide charging capabilities through the USB ports. Supplementary charging through an AC adapter and outlet is still required.

Note: The iPad® has a single cord for charging and syncing (see below). This cord must be moved from the AC adapter to the hub for syncing. Many tablet devices use this same type of configuration. Some have a separate power cord and separate USB cord to accomplish both syncing and charging functions. Please consult the owners manual of your specific tablet device for further information.

iPad® Charge Mode

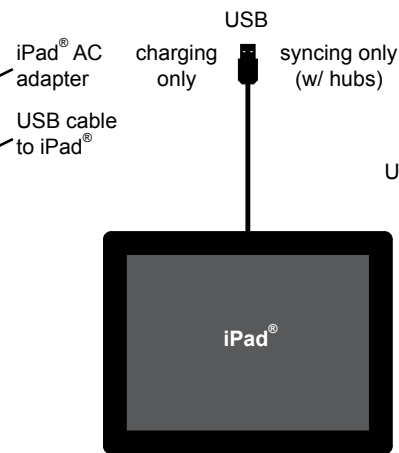
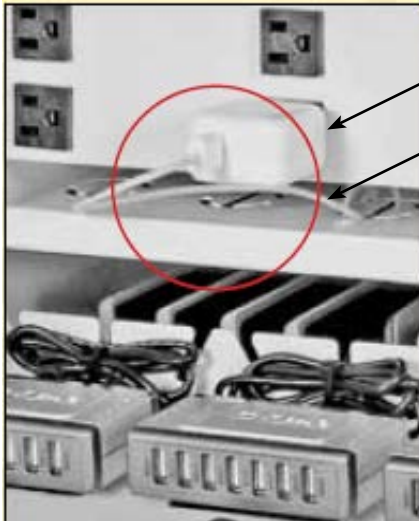

iPad® Sync Mode

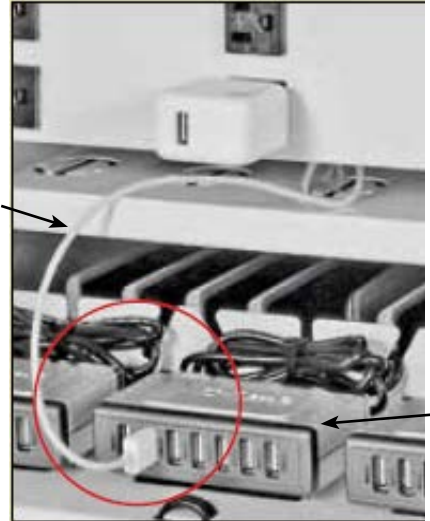

Optional Syncing USB Hub Specs



Rear View



Front View

Minimum System Requirements

- Computer with Windows[®] 7, Windows Vista[®], Windows[®] XP SP2, Windows[®] 2000 SP4, Mac OS[®] X 10.4 or higher
- Computer with USB 1.1 port

USB Hub Specs

Standards

- USB specification version 2.0 1 (data rates of up to 480 Mbps)
- USB specification version 1.1 (data rates of up to 12 Mbps)
- OHCI
- UHCI
- VEHCI

Interfaces

- 1 upstream USB 2.0 Type B (female) port
- 7 downstream USB 2.0 Type A (female) ports (including 2 Fast Charging ports)

Connectivity Rules

- Up to five cascaded hubs
- Maximum cable length between each hub: 5m
- Up to 127 devices

Diagnostic LED

- Standard Mode (blue)
- Fast-Charge Mode (green)

Supplied Charging Current

- Standard Mode:
 - All seven USB ports - 0.5 A per port 2
- Fast-Charge Mode:
 - 5 standard USB ports- 0.5 A per port 2
 - 2 USB fast charging ports - 1.2 A per port 2

Power Input

- + 5 V / 3 A DC

Dimensions (L x W x H)

- + 3.94 x 2.2 x 0.9 inches (100 x 57 x 23 mm)

Weight

- 0.19 lbs (85 g)

Operating Temperature

- 32 to 104°F (0 to 40°C)

Storage Temperature

- -4 to 158°F (-20 to 70°C)

Operating Humidity

- 5% to 95% (non-condensing)

Storage Humidity

- 0% to 95% (non-condensing)

Certifications

- FCC
- CE
- C-Tick
- VCCI
- IC
- RoHS

Warranty

WE WILL MAKE IT RIGHT FOR YOU!

Spectrum is committed to provide complete customer satisfaction. Each of our products is manufactured from the best materials available and each product is stringently monitored throughout the production process through our P.A.C.E. program (Product Assurance to meet Customer Expectations).

We expressly warrant that Spectrum products will be of good quality and workmanship and free from defect for the period set out in the warranty table below from the date of delivery. This warranty shall not apply to defects or damage resulting from misuse, abuse, neglect, improper care, modification or repair not authorized by Spectrum, or any other cause outside the control of Spectrum. Spectrum will, at its sole option, either repair or replace the defective product.

This warranty is exclusive; no other warranty, written or oral, is expressed or implied. This warranty is given by Spectrum to Buyer and to no other person or legal entity. No Spectrum dealer, distributor, agent or employee is authorized to make any modification or addition to this warranty.

NOTWITHSTANDING ANYTHING TO THE CONTRARY, SPECTRUM WILL NOT UNDER ANY CIRCUMSTANCES BE LIABLE FOR INDIRECT OR LIQUIDATED DAMAGES, INCLUDING CONSEQUENTIAL, INCIDENTAL AND SPECIAL DAMAGES. IN NO EVENT SHALL SPECTRUM'S LIABILITY, WHETHER UNDER CONTRACT OR WARRANTY, IN TORT OR OTHERWISE, EXCEED THE PURCHASE PRICE RECEIVED BY SPECTRUM FOR THE PRODUCT AT ISSUE AND "RECALL ACTION" EXPENSES. SPECTRUM SHALL NOT BE SUBJECT TO ANY OTHER OBLIGATIONS OR LIABILITIES, WHETHER ARISING OUT OF BREACH OF CONTRACT, WARRANTY, TORT (INCLUDING NEGLIGENCE AND STRICT LIABILITY) OR OTHER THEORIES OF LAW, WITH RESPECT TO PRODUCTS SOLD OR SERVICES RENDERED BY SPECTRUM, OR ANY UNDERTAKINGS, ACTS OR OMISSIONS RELATING THERETO.

Our Customer Service Department is ready to provide immediate attention to any questions, comments or concerns. They are available to answer your calls Monday through Friday from 7 am to 5 pm CST. In addition your product comments or concerns are welcome via e-mail at: spectrum@spectrumfurniture.com.

Warranty Table

Item	Warranty Period
<ul style="list-style-type: none"> Adjustable Crank/Electric Desk Legs Flat Panel Desk Gas Cylinders 	<ul style="list-style-type: none"> 1 Year
<ul style="list-style-type: none"> Adjustable Height Chair Parts – including frames, gas cylinders, wood and plastic parts, and control handles Adjustable Height Chair Parts Casters Adjustable Height Chair Upholstery In-Stock Upholstery Graded-In Fabrics and Customer Owned Material 	<ul style="list-style-type: none"> 7 Years 2 Years 2 Years No Warranty
<ul style="list-style-type: none"> Height Adjustable Columns and Lifts General Use Casters Electrical Keyboard/Mouse Trays 	<ul style="list-style-type: none"> 1 Year
<ul style="list-style-type: none"> Flat Panel Monitor Arm – General Parts Flat Panel Monitor Arm – Gas Cylinders 	<ul style="list-style-type: none"> 5 Years 2 Years
<ul style="list-style-type: none"> Computer Desk Chassis Cart Chassis Lectern Chassis 	<ul style="list-style-type: none"> 10 Years

