

Technical Specifications

55320

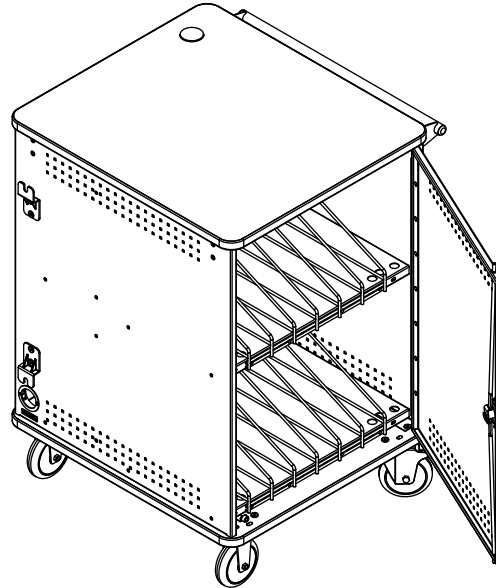

Use the vLT-15 Cart to store 15 full-size laptops where security and mobility is required. Padded shelves protect the laptops and vertical storage provides easy access to the laptops. Power cords hang over each bay for quick power management. Line voltage access is separated from the laptops access. Dual-bolt locks on the doors increase security of the laptops and keep students from the line voltage. The vLT-15 Cart is made with powder coated steel for security and durable, long-lasting finish. The 5-inch balloon wheels reduce vibration and roll easily over uneven floors.

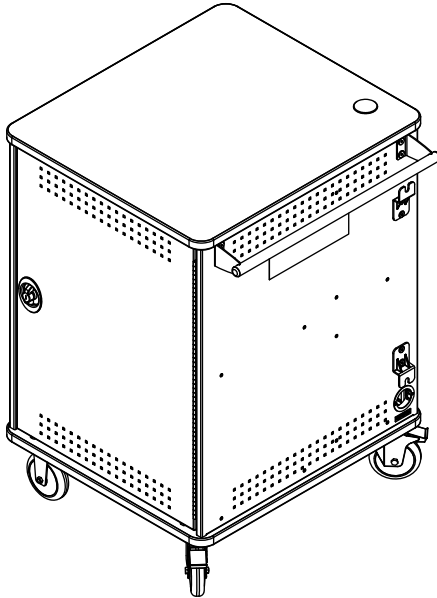

Features and Benefits

- Stores, charges, and transports up to 15 full-size notebooks (laptops)
 - Ample clearance is provided for easy removal/insertion of laptops
 - Double bolt keyed locks and heavy-gauge steel doors provide security
 - Padded shelves and coated dividers protect laptops from damage
 - Laptops and students are separated from all line voltage
 - Superior, all-metal overhead cord management system keeps charge cords organized above each storage bay
-
- Cord management system keeps charge cords organized at the back of each storage bay (Velcro® tie-downs included)
 - Electrical system consists of UL-Listed components
 - 16-outlet power unit with 15-amp breaker and reset button
 - Ventilated doors and side panels keep notebooks and chargers cool, preventing overheating, and extending device life
 - Worksurface and bottom panel grommets keep wires and cords manageable
 - External cord wrap brackets provide easy power access
-
- Four inboard 5" locking balloon wheel plate casters with metal construction and non-marring rubber provide easy rolling, and quiet transport (rated for 325 lb each)
 - One all steel handle provides control and maneuverability
 - Worksurface and base panel vinyl edging protects walls and furniture
-
- Durable powder coated steel chassis provides a long-lasting finish
 - Scratch and impact-resistant high-pressure laminate top provides a durable, useful worksurface for instructor
 - SCS Indoor Advantage Certified; meets or exceeds applicable UL test standards
 - Warranted to be free of all defects in materials and workmanship for 10 years, electrical system 2 years
 - Assembled in Chippewa Falls, WI, USA

Base
BW - 4 swivel 5" Balloon Wheels
SR - 2 rigid, 2 swivel 5" Balloon Wheels

Color Options

Standard laminate / color combinations

Wild Cherry / Black (CHB) 

Indigo Organix / Black (IB) 

Standard color combination refers to the quickest deliverable product color combination. Custom laminates and color combinations are available—additional lead-times and up-charges may apply. Call 1-800-235-1262 for further information.

Construction

- The worksurface and base panel is constructed from 1.063" NAUF (No Added Urea Formaldehyde) composite board with .030" high-pressure laminate on one face, and a balancing phenolic backer on the opposing face
- 16-gauge side panels, and front door
- 20-gauge shelves
- All metal components are finished with a scratch-resistant powder coat epoxy
- Worksurface edges are covered with 3mm vinyl
- Each vLT-15 Laptop Cart is factory-assembled, packaged, and shipped on its own skid (*handle, and cord wrap brackets to be installed by customer*)

Specifications

Capacity	15 Laptops	
Storage bays (nominal)	16 bays available 2.75"W [7 cm] x 16.1875"D [41.1 cm] x 14.75"H [37.5 cm]	
Electrical	<ul style="list-style-type: none"> • One 16-outlet 12-amp, 125 volt, 60Hz power unit • 125V~/12A, 60Hz • 15-amp breaker • On/off switch • 15' nominal 14 AWG, 3-wire power cord 	<ul style="list-style-type: none"> • Outlets are separate from laptops and are accessible from the back of the unit with a locking door • UL-Listed components.
5" Balloon Wheels	Weight capacity 325 lb [148 kg] each	
Unit weight (nominal)	176 lb [79.9 kg]	
Shipping weight (nominal)	226 lb [102.6 kg]	

Specifications subject to change without notice

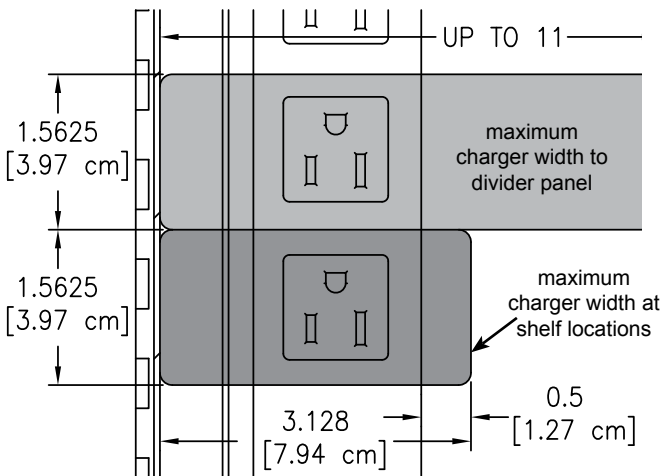

Nominal outlet spacing on each 16-outlet power unit

Caution
This cart is intended for use only with the maximum weights indicated. Use with appliances heavier than the maximum weights indicated may result in instability causing possible injury.

Caution
Maximum load not to exceed 40 lb per rear shelf

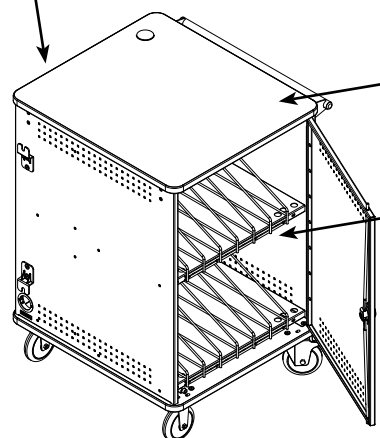

Caution
Maximum load not to exceed 180 lb on worksurface

Caution
Maximum load not to exceed 89 lb per shelf

vLT-15 Laptop Cart

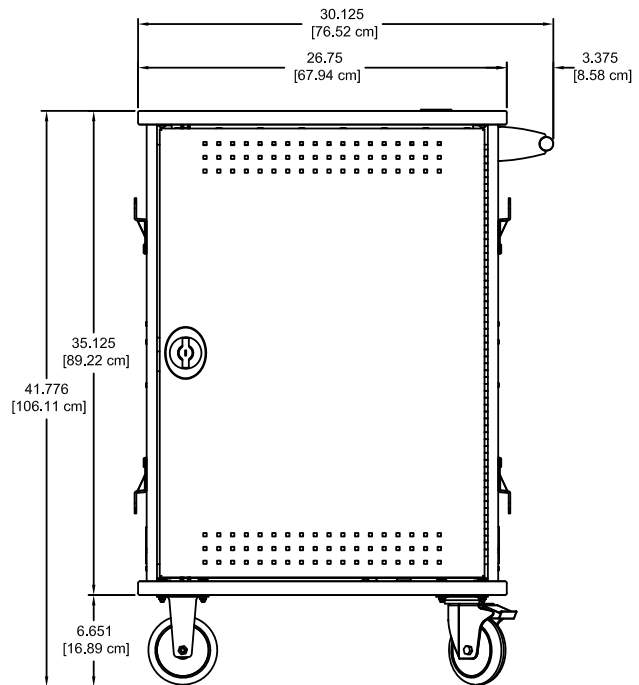
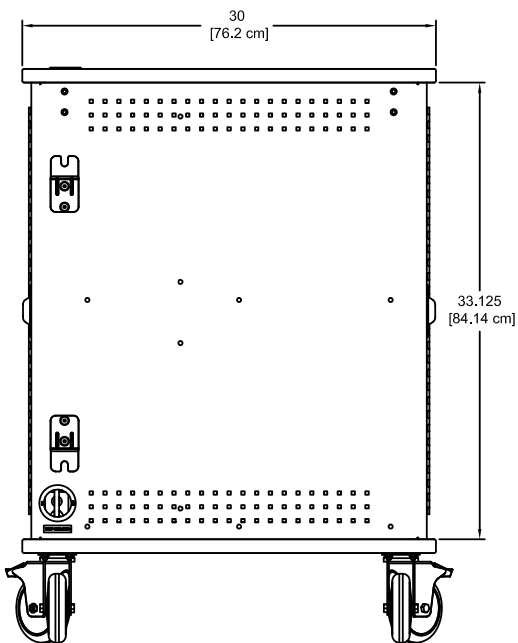
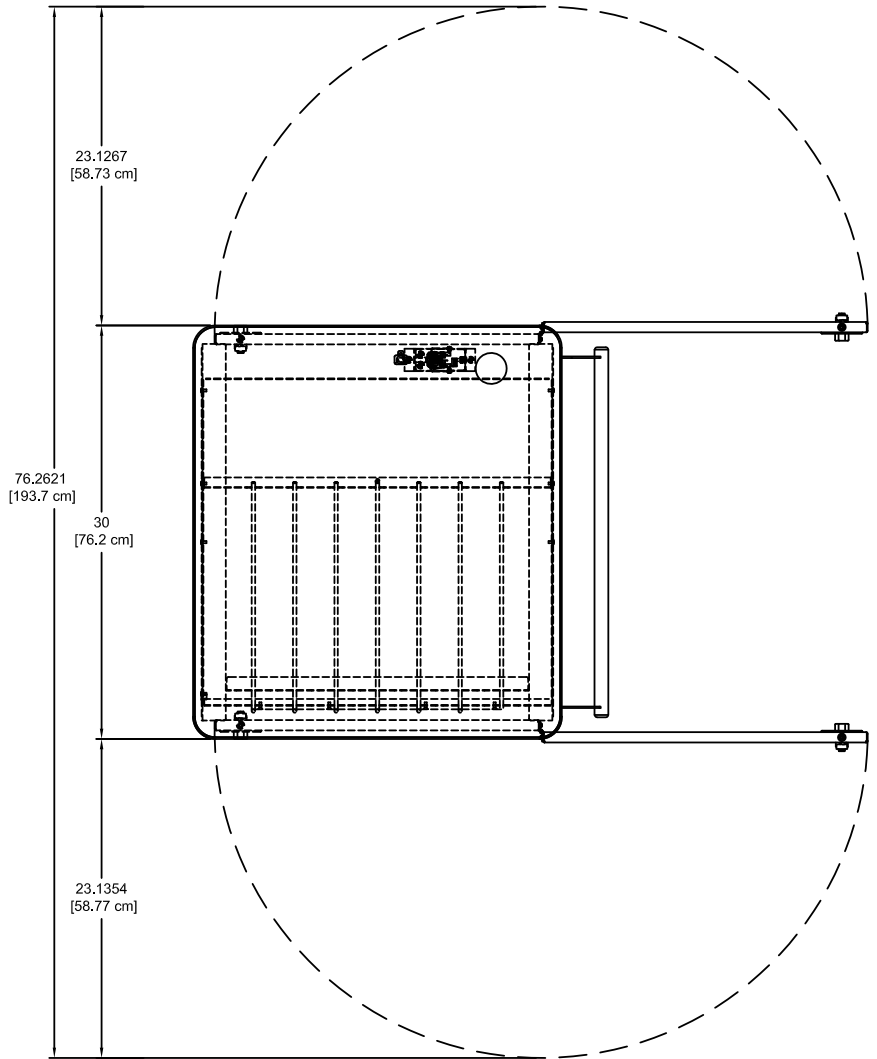
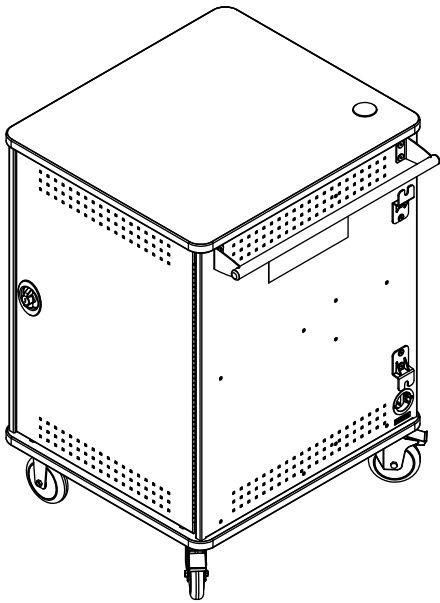

vLT-15 section view

power side

student side

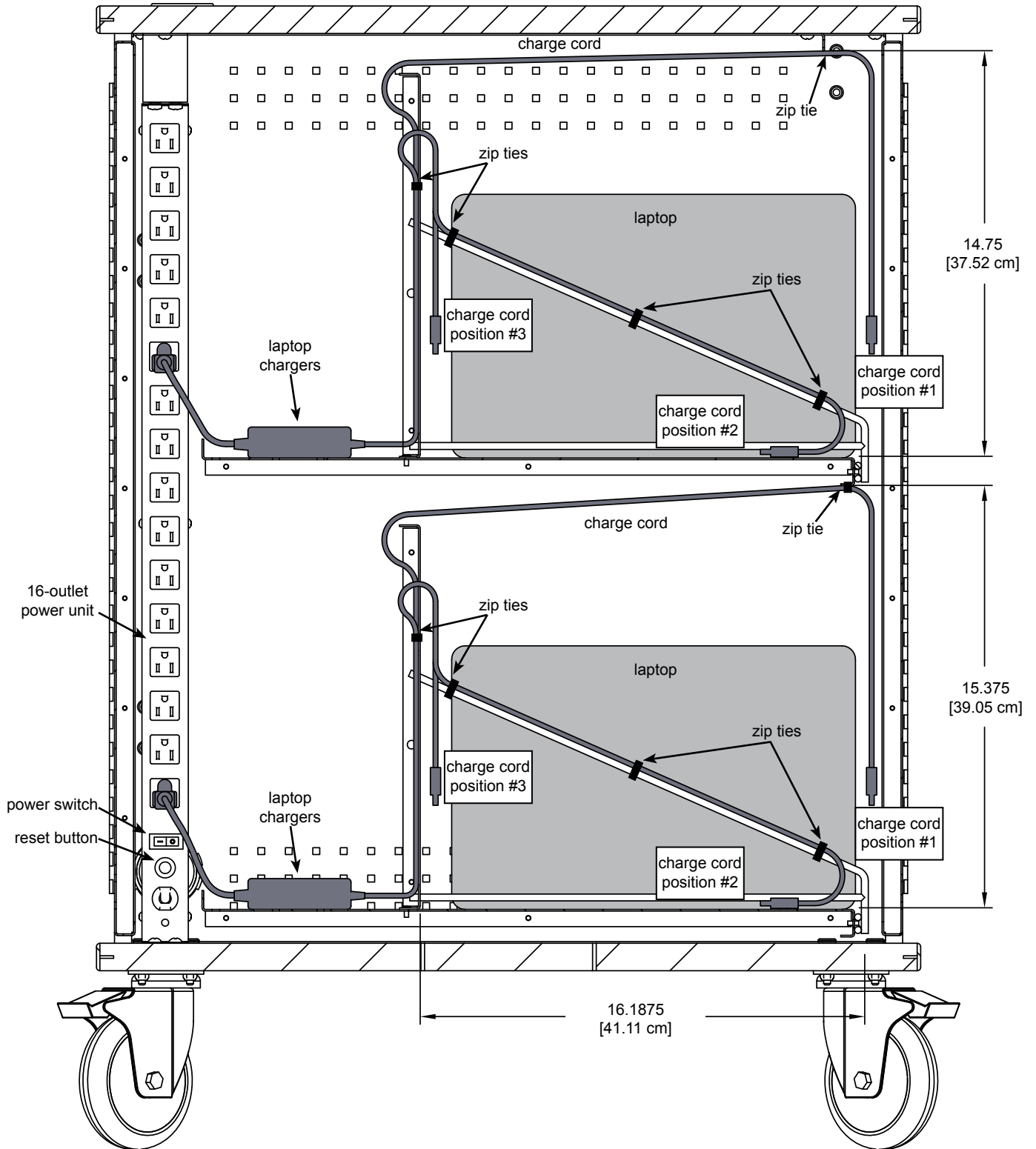

vLT-15 cord management
student side view
(shown without door)

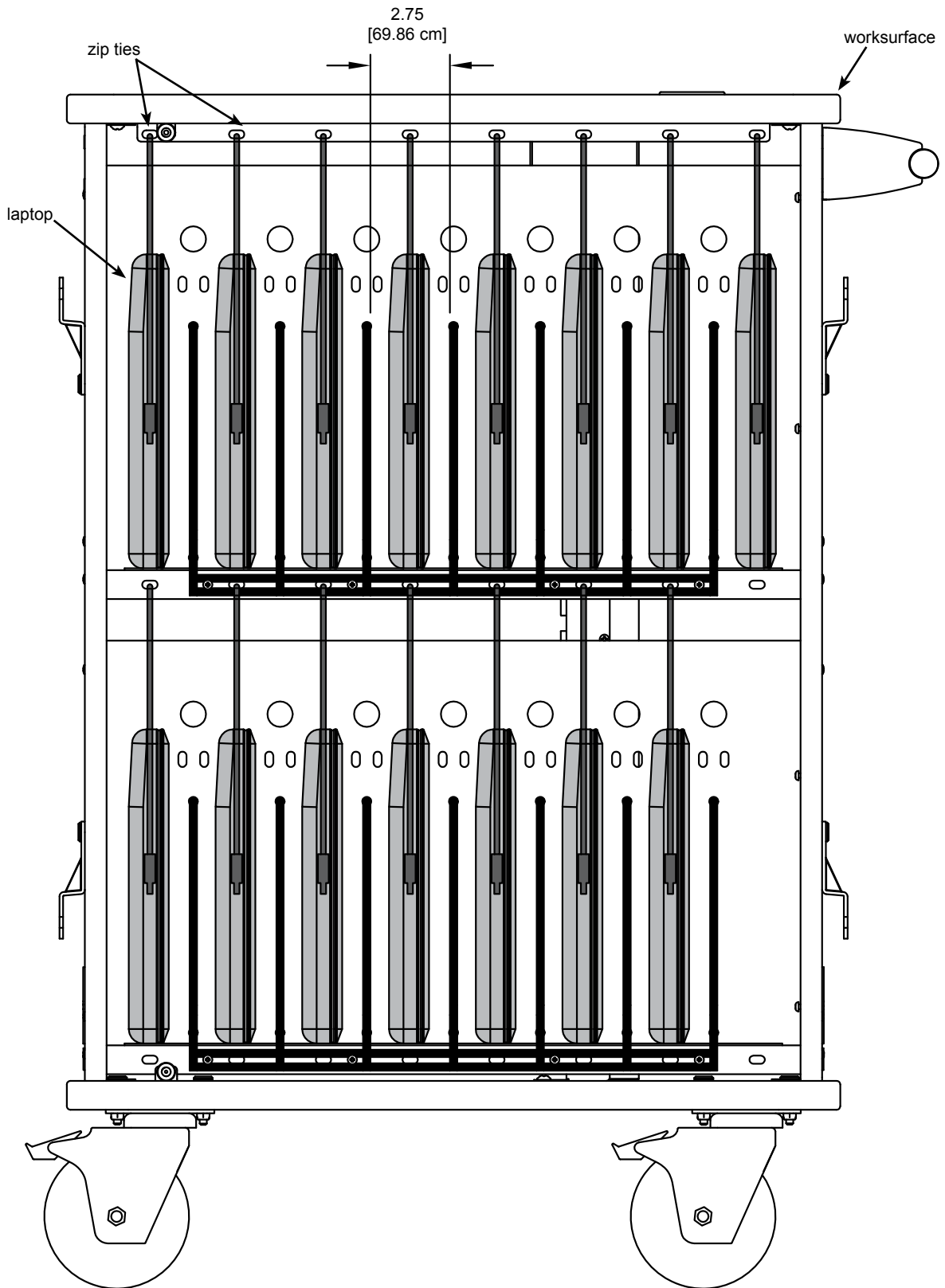

top view of cord management tray

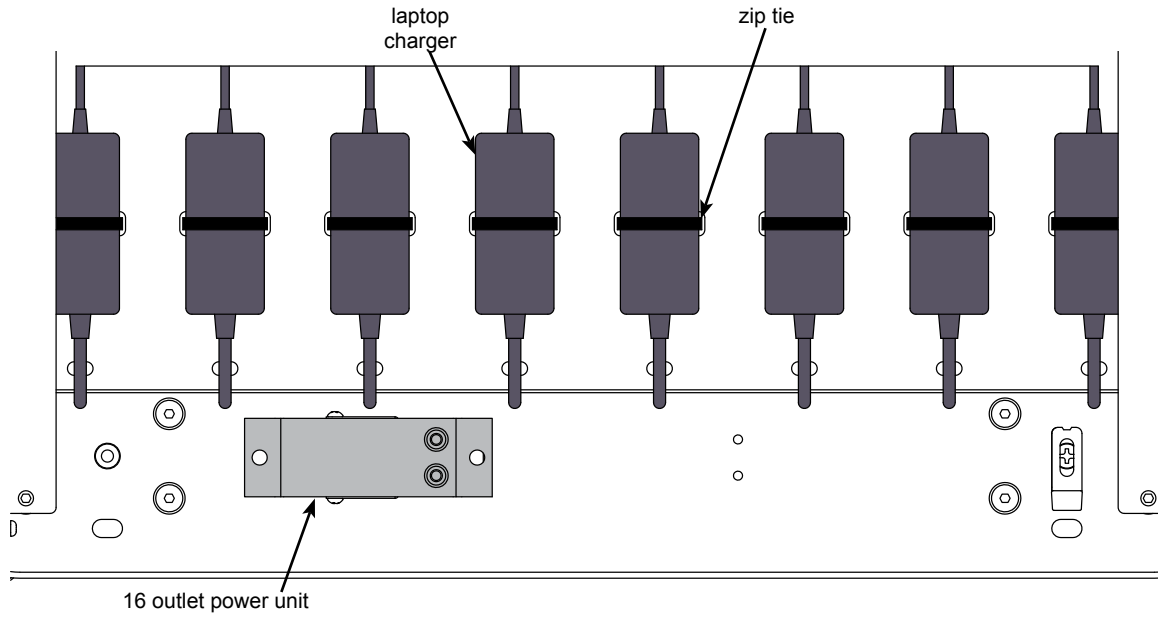

power-side views (shown with door removed)

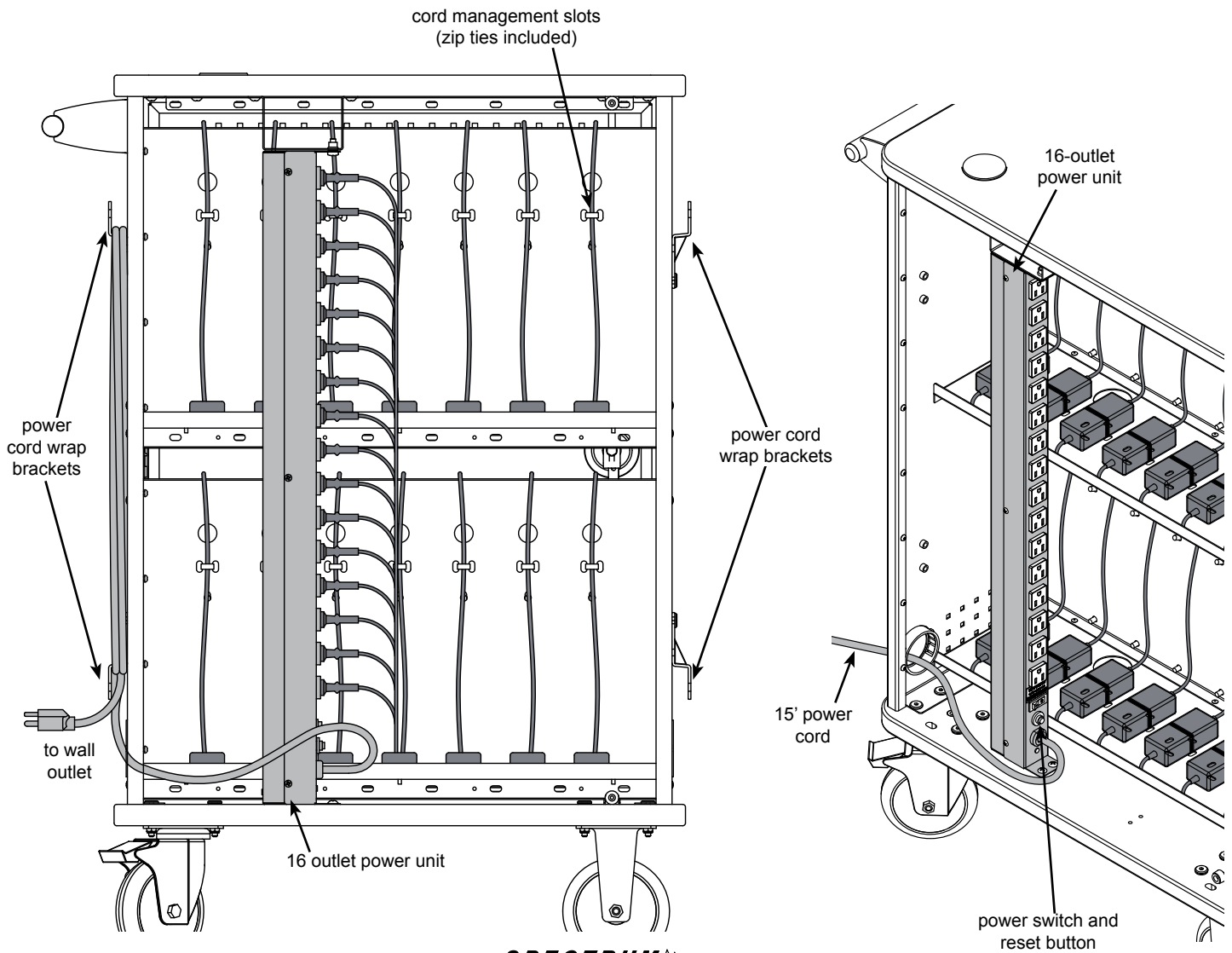

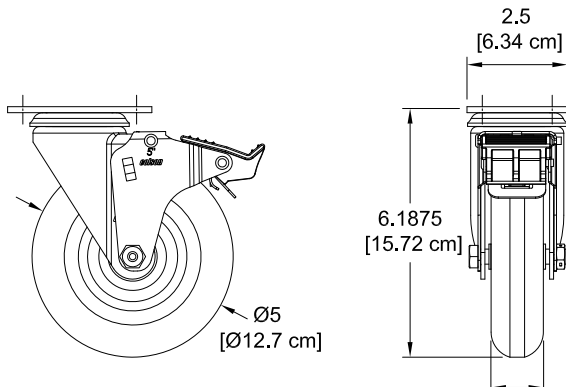

5" balloon wheel (BW)

BW
5" Balloon Wheels (4 swivel)

Provides more maneuverability in tight spaces, but less control when mobile

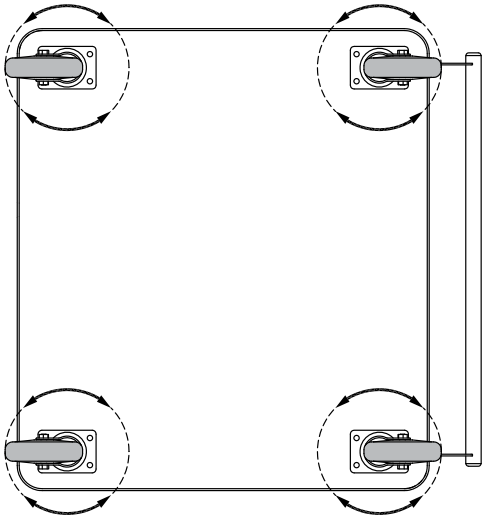

SR
5" Balloon Wheels (2 swivel, 2 rigid)

Provides more control when mobile, but less maneuverability in tight spaces

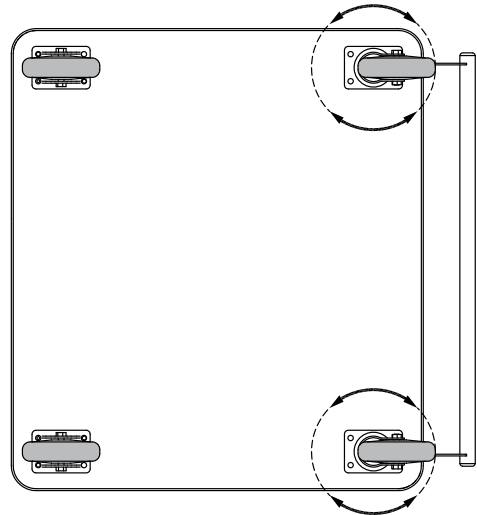

Note: If you have the SR version on your particular cart, mounting the handle on the same side as the two swivel wheels will provide more control of the cart when mobile.

Options



Hook-and-loop strap kit
(16) .75" [1.91 cm] x 12" [30.48 cm],
and (32) .75" [1.91 cm] x 5" [12.7 cm]
95004

Warranty

WE WILL MAKE IT RIGHT FOR YOU!

Spectrum is committed to provide complete customer satisfaction. Each of our products is manufactured from the best materials available and each product is stringently monitored throughout the production process through our P.A.C.E. program (Product Assurance to meet Customer Expectations).

We expressly warrant that Spectrum products will be of good quality and workmanship and free from defect for the period set out in the warranty table below from the date of delivery. This warranty shall not apply to defects or damage resulting from misuse, abuse, neglect, improper care, modification or repair not authorized by Spectrum, or any other cause outside the control of Spectrum. Spectrum will, at its sole option, either repair or replace the defective product.

This warranty is exclusive; no other warranty, written or oral, is expressed or implied. This warranty is given by Spectrum to Buyer and to no other person or legal entity. No Spectrum dealer, distributor, agent or employee is authorized to make any modification or addition to this warranty.

NOTWITHSTANDING ANYTHING TO THE CONTRARY, SPECTRUM WILL NOT UNDER ANY CIRCUMSTANCES BE LIABLE FOR INDIRECT OR LIQUIDATED DAMAGES, INCLUDING CONSEQUENTIAL, INCIDENTAL AND SPECIAL DAMAGES. IN NO EVENT SHALL SPECTRUM'S LIABILITY, WHETHER UNDER CONTRACT OR WARRANTY, IN TORT OR OTHERWISE, EXCEED THE PURCHASE PRICE RECEIVED BY SPECTRUM FOR THE PRODUCT AT ISSUE AND "RECALL ACTION" EXPENSES. SPECTRUM SHALL NOT BE SUBJECT TO ANY OTHER OBLIGATIONS OR LIABILITIES, WHETHER ARISING OUT OF BREACH OF CONTRACT, WARRANTY, TORT (INCLUDING NEGLIGENCE AND STRICT LIABILITY) OR OTHER THEORIES OF LAW, WITH RESPECT TO PRODUCTS SOLD OR SERVICES RENDERED BY SPECTRUM, OR ANY UNDERTAKINGS, ACTS OR OMISSIONS RELATING THERETO.

Our Customer Service Department is ready to provide immediate attention to any questions, comments or concerns. They are available to answer your calls Monday through Friday from 7 am to 5 pm CST. In addition your product comments or concerns are welcome via e-mail at: spectrum@spectrumfurniture.com.

Warranty Table

effective 1/1/2015

Item	Warranty Period
Adjustable Crank/Electric Desk Legs	• 1 Year
Flat Panel Desk Gas Cylinders	
Chairs <ul style="list-style-type: none"> • Adjustable Height Chair Parts – including frames, gas cylinders, wood and plastic parts, control handles, casters • Adjustable Height Chair Upholstery • In-Stock Upholstery • Graded-In Fabrics and Customer Owned Material 	<ul style="list-style-type: none"> • 7 Years • 2 Years • 2 Years • No Warranty
Height Adjustable Columns and Lifts	• 1 Year
General Use Casters	
Electrical	• 2 Years
Keyboard/Mouse Trays	• 1 Year
Flat Panel Monitor Arms <ul style="list-style-type: none"> • Flat Panel Monitor Arm – General Parts • Flat Panel Monitor Arm – Gas Cylinders 	<ul style="list-style-type: none"> • 5 Years • 2 Years
Desks and Lecterns <ul style="list-style-type: none"> • Computer Desk Chassis • Cart Chassis • Lectern Chassis 	• 10 Years

