

# Media Director Lectern

55160HD - w/ Heavy-Duty Casters  
55160TK - w/ Toe Kick



**\$1499**

(Available while quantities last)



(Accessories not included)



- Dark Gray steel
- Indigo Organix laminate (ID)



## Features and Benefits

- Front and rear rack-rail equipment mounting simplifies installation for any equipment configuration with enough space for an internal CPU
- Standard rack rail brackets allow the front and rear rack rails to be moved further inside the unit, if necessary, to accommodate larger knobs and plugs
- Ventilated side panels keep equipment cool
- Scratch and impact resistant 1-1/16" High pressure laminate worksurface
- Cable grommets throughout the unit keep wires and cords manageable
- Two 4" cable management grommets are located on the top and bottom of the center divider allows easy cord management between the right and left compartments
- Two rectangular worksurface grommets provides cable access or the ability to mount Power / Communication Modules
- Low-profile, flush-cup, two-point locking doors on the front and back provide security and easy-access to the front and rear of the unit making it easy to maintain audio, video, and multi-media equipment
- Standard keyboard tray provides convenient keyboard access
- Audio slot locations on the student-side doors for customer-mounted speakers
- Standard adjustable-height, flip-up document camera/task shelf provides a convenient additional worksurface
- Four 4" heavy-duty swivel, locking casters (HD)
- Removable acrylic viewing/access panels on the front doors provide easy monitoring and access to internal equipment
- Guaranteed to be free of all defects in materials and workmanship with a 10-year warranty

## Construction

- The worksurface and base panel are constructed from 1" thick industrial-grade composite board with .030 high-pressure laminate on one face, and a balancing phenolic backer on the opposing face
- Metal components consist of 16-gauge steel and 20-gauge perforated steel
- Welded, 16-gauge 1" x 2" rectangular steel tube frame
- Worksurface edges are covered with 3mm vinyl
- All metal components are finished with a scratch-resistant powder coat epoxy
- Each Media Director is factory assembled w/ casters, packaged, and shipped on its own skid

# Capacity

- Overall dimensions: 46"W x 30"D x 42-9/16"H
- Total upper internal area: 40-1/4"W x 27"D x 6-1/8"H
- Total lower internal area: 40-1/4"W x 27"D x 25-1/2"H
- Adjustable-height document camera/task shelf is 23"W x 27-3/4"D
- Rectangular worksurface grommets are 7-1/4"W x 3-7/8"D each
- The 4" heavy-duty casters have a weight capacity of 300 lbs each
- Standard rack rail provides 13RU
- Meets or exceeds all ANSI-BIFMA test standards

**Unit weights:**

55160HD - 260 lbs w/ casters  
 55160TK - 263 lbs w/ toe kick

**Shipping weights:**

55160HD - 316 lbs w/ casters  
 55160TK - 334 lbs w/ Toe Kick

**55160HD**

*Media Director w/ Heavy-Duty Casters  
 (Shown with optional Flip-up shelf and Adjustable Keyboard Tray)*

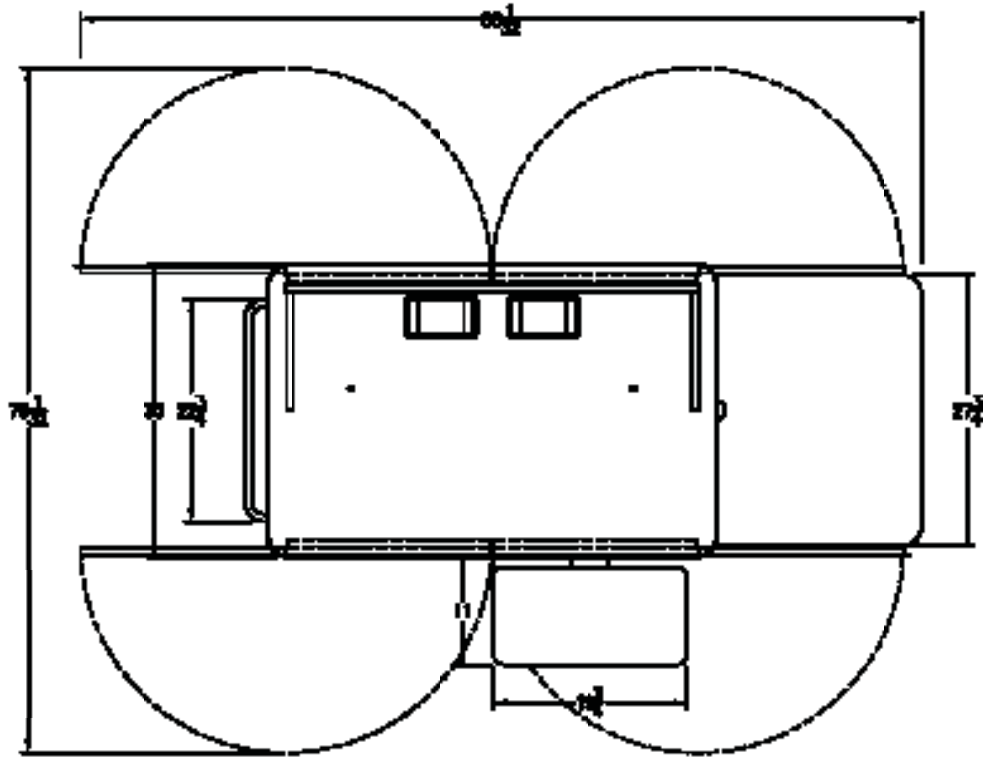

Top View

**Note:** Standard keyboard tray can be mounted in a left or right position under the worksurface.

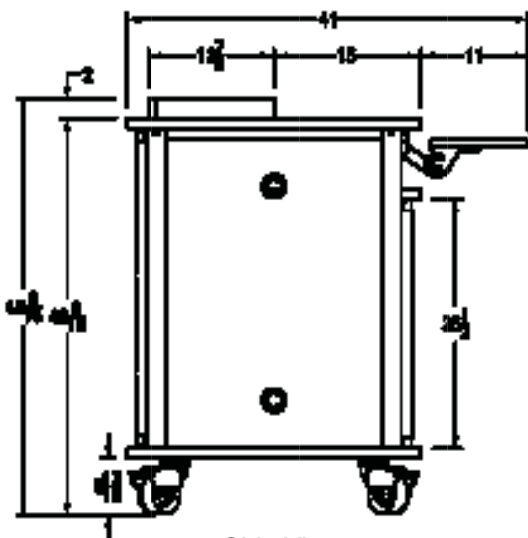

Side View

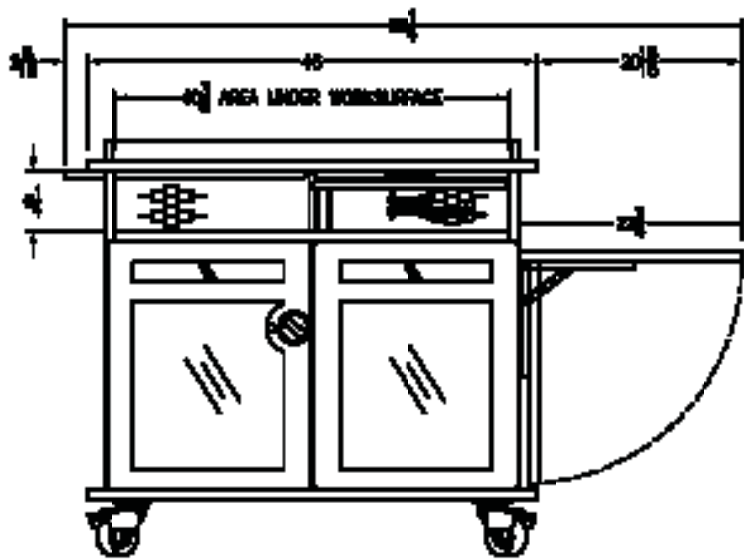

Front View

55160TK  
 Media Director w/ Toe Kick  
 (Shown with optional Flip-up shelf and Adjustable Keyboard Tray)

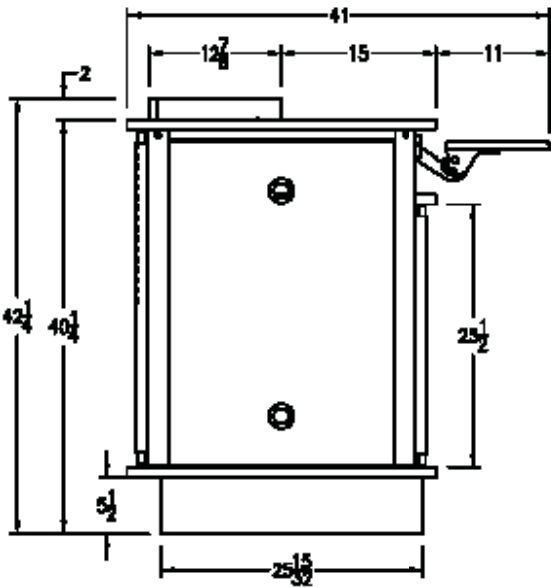

Side View

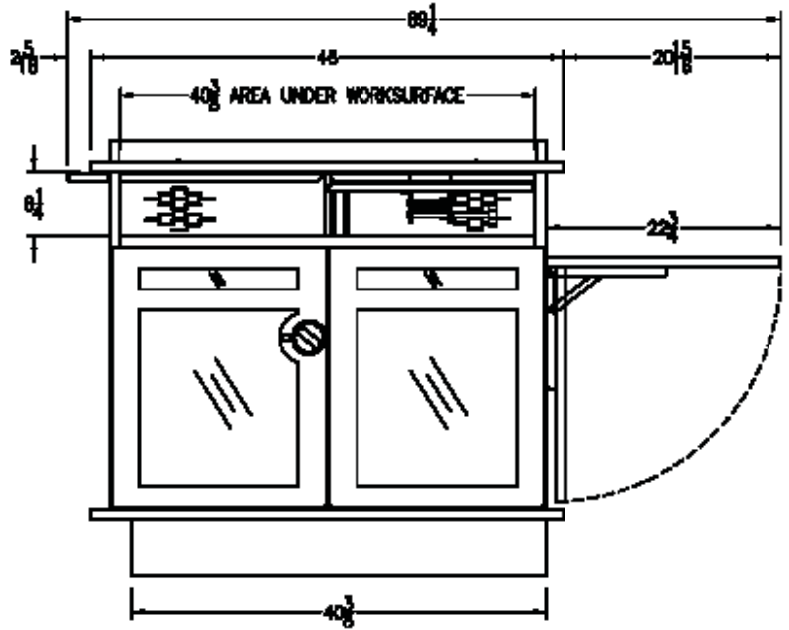

Front View

# Media Director Options

**Note:** Flip-Up Document Camera Shelf and Steel Handle are interchangeable and can be mounted on either side.

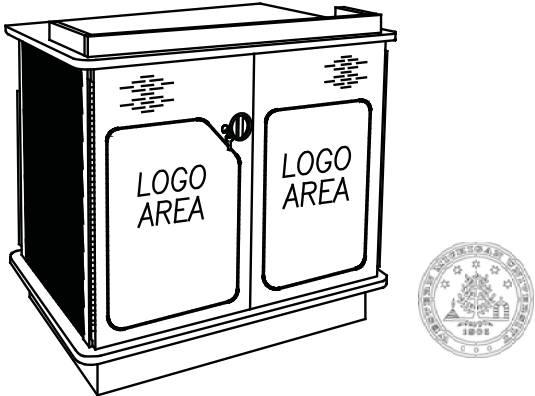

**Custom-Cut Logo**  
(Typical logo locations-shown on student-side)  
55141

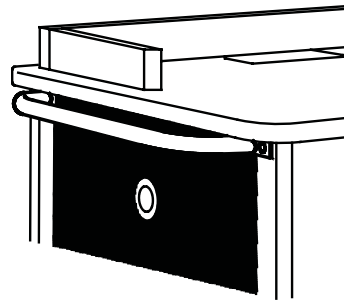

**Steel Handle**  
(mounts on left or right-max 2 per unit)  
55265

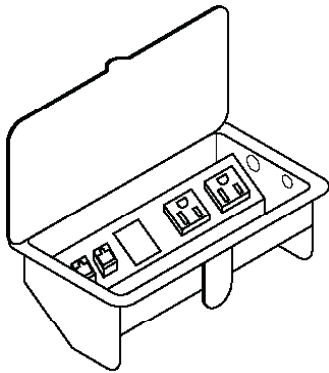

**Power/Communication Module**  
w/9' power cord, two outlets, two data jacks  
7-1/8"W x 3-5/8"D  
99002 (w/mic jack)  
99003 (w/out mic jack)

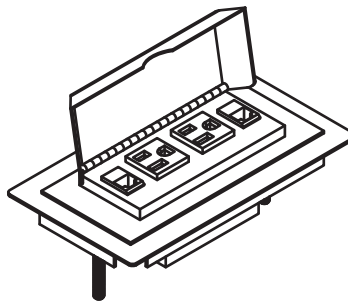

**UL Listed Power/Communication Module**  
w/9' power cord, two outlets, two data jacks,  
and adapter plate  
7-1/8"W x 3-5/8"D x 3/4"H  
99028

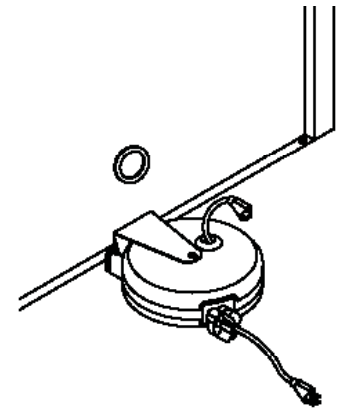

**15' Retractable Cord Reel**  
inboard-mounted (15-amp)  
99029

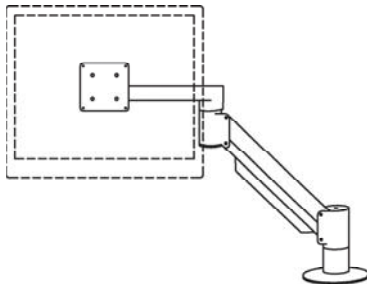

**Flat Panel Monitor Arm**  
95512 (for monitors weighing 4-14.5 lbs)  
95522 (for monitors weighing 9-24 lbs)  
95509 (for monitors weighing 12-29 lbs)

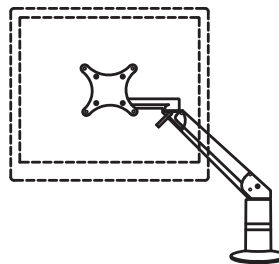

**Evo Flat Panel Monitor Arm**  
95523 (for 15"-19" monitors weighing 6-13 lbs)  
95524 (for 19"-21" monitors weighing 13-21 lbs)

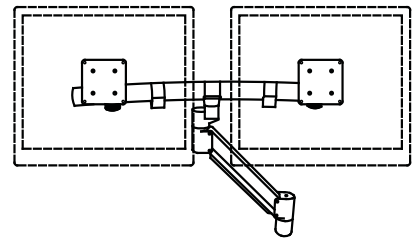

**Dual Flat Panel Monitor Arm**  
(23" max center-to-center distance)  
(4-19 lbs per monitor)  
95516

# Rack-mount Options

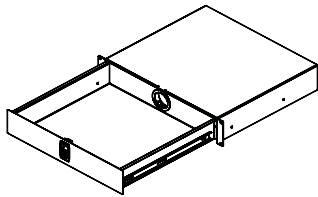

**Locking Drawer (2RU)**  
 interior dims: 15-3/4"W x 13-11/16"D x 2-7/8"H  
 (25 lbs max load)  
 97514

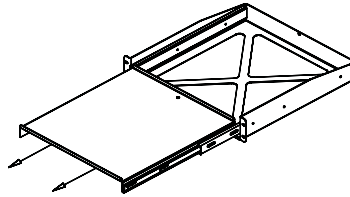

**Pull-Out Shelf (2RU)**  
 16-1/2"W x 17-3/4"D  
 (50 lbs max load)  
 97505

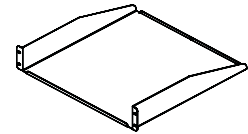

**Cantilever Shelf (2RU)**  
 17-1/2"W x 18"D x 3-1/2"H  
 (50 lbs max load)  
 97504

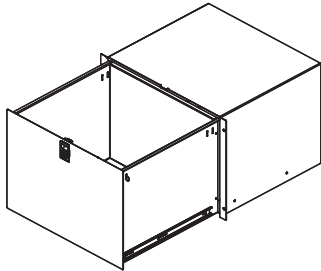

**Locking File Drawer (8RU)**  
 includes file holder  
 interior dims: 15-3/4"W x 13-9/16"D x 13-5/16"H  
 (50 lbs max load)  
 97515

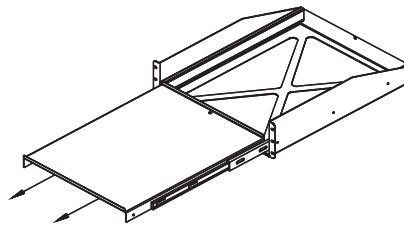

**Pull-Out Shelf (3RU)**  
 16-1/2"W x 21-3/4"D  
 (80 lbs max load)  
 97503

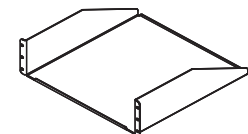

**Cantilever Shelf (3RU)**  
 17-1/2"W x 18"D x 5-1/4"H  
 (80 lbs max load)  
 97502

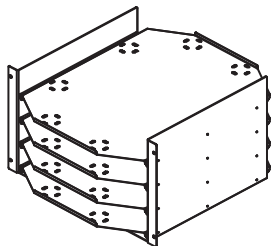

**LT-4 Laptop Storage Unit (7RU)**  
 (stores 4 laptops horizontally)  
 laptop tray dims:  
 16-1/4"W x 20-1/2"D x 2-3/16"H  
 97517

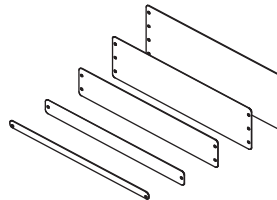

**Rack-Mount Blanks**  
 (fills rack spaces where components are not needed)  
 97516 - (1/2RU)  
 97510 - (1RU)

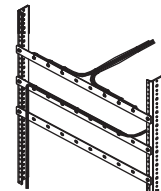

**Wire Lace Kit**  
 3 lace straps included  
 95517

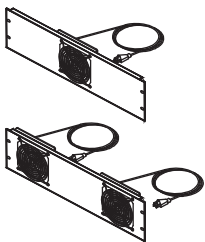

**Cooling Fans (3RU)**  
 19"W x 2"D x 5-1/4"H  
 Single Fan-97507  
 Double Fan-97506

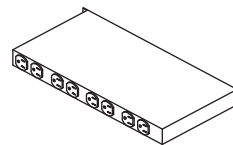

**9-Outlet Power Strip (1RU)**  
 19"W x 9"D x 1-3/4"H  
 99021