

Instructions:

To purchase parts or accessories, please contact us at
www.spectrumfurniture.com
1-800-235-1262
Thank you for choosing Spectrum products!

Before you begin, please make sure all parts and proper quantities are included. Any parts damaged during shipment must be reported within 15 days of receipt. To report information regarding damages or if you have any questions, please call 1-800-235-1262.

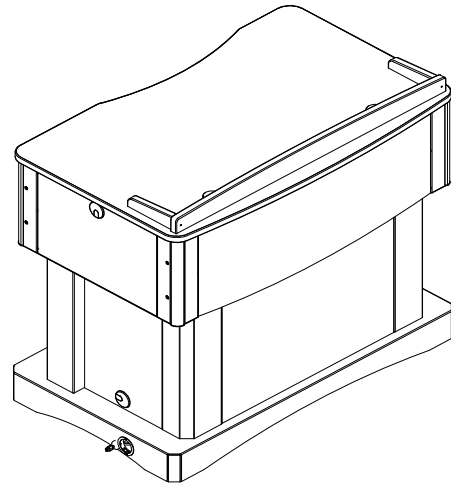

Freedom Lectern #55300

Moving the Lectern

- Unplug the power cord.
- Be sure the instructor-side casters are in the unlocked position and push the lectern from the left or right side.
If your lectern is equipped with the optional flip-up shelf, be sure the shelf is lowered before moving.
- Use caution when approaching door jambs and thresholds to not damage the caster surround (lower portion of the unit.)
- Lock the instructor-side casters after moving.

Operating lift mechanism

CAUTION

Although this desk utilizes a safety device that briefly stops and reverses the motion of the desk in the event of an obstruction, use caution when raising or lowering the unit. **Do not** sit at or under the worksurface when operating the lift mechanism and be sure desk movement does not interfere with objects or people.

- Back up from the unit before operating.
- To raise or lower the lectern, press and hold the "up" or "down" arrow keys until the desired height is achieved. **Figure 1**. The worksurface can be raised to a maximum height of 40" and lowered to a minimum height of 28". The lift actuators are rated at a maximum of 180lbs.

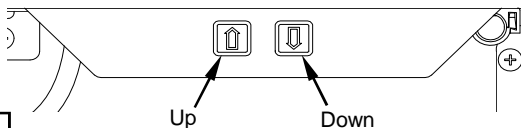

Figure 1

Resetting lift mechanism

- Occasionally it may be necessary to reset the lift mechanism. This should be done if the desk does not extend or retract. To reset, first unplug and re-plug in the power cord.
- Press and hold the "Down" arrow key until the column has bottomed-out for 10 seconds. This will reset the drive unit, and allow normal operation to resume.

Optional Folding Shelf Operation

- To raise and lock the shelf into place, lift up on the shelf until it 'clicks' and locks into a fully-horizontal position.
- To lower the shelf, locate the shelf bracket release levers under the shelf. Lift up slightly on the shelf while releasing the levers and slowly allow the shelf to swing down. **Figure 2**. **Make sure the shelf is fully-supported while lowering.**

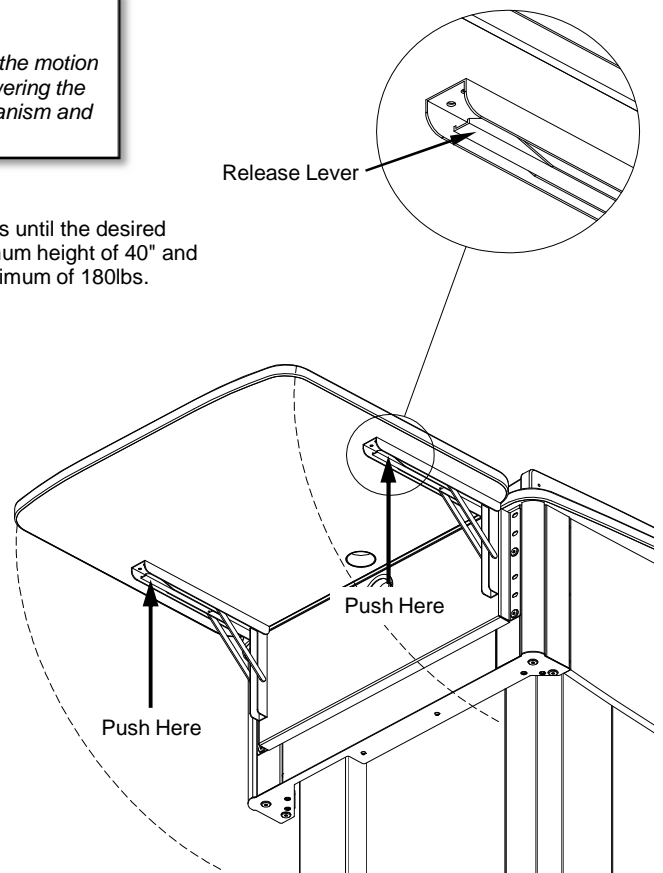
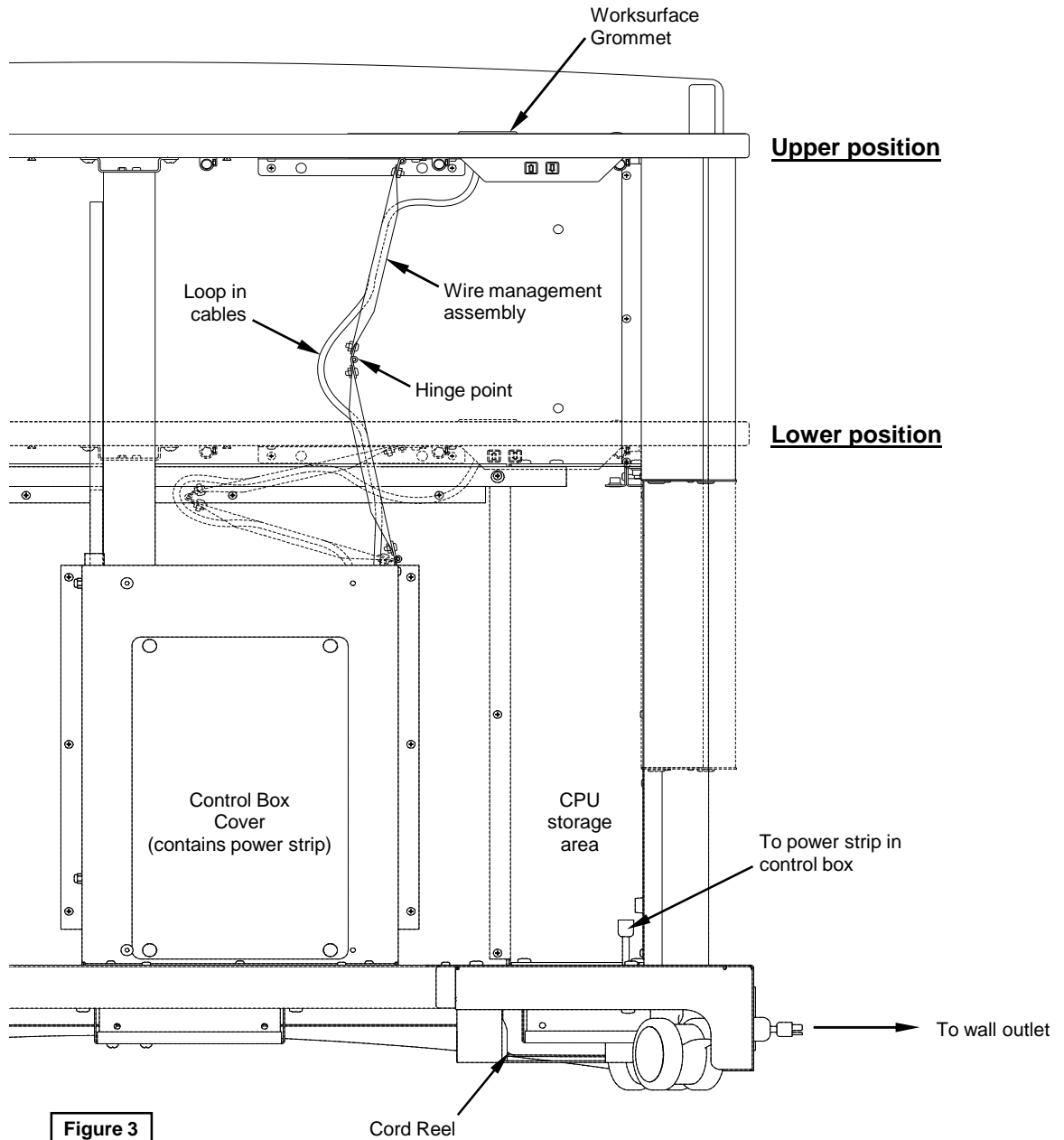

Figure 2

Cord Management

- A. To route cords and wires from the worksurface to the control box/power strip, fully-extend the unit.
- B. Locate the wire management assembly under the worksurface.
- C. Route cords from the worksurface through the wire management assembly as shown in **Figure 3**.
Be sure enough slack is provided in the cables while looping around the hinge point, and secure with wire ties.



Cord Reel Operation

- A. The cord reel provides 20' of cord and is rated at a maximum of 13-amps.
- B. To latch, pull cord out to full-length. Allow the cord to retract 1-2 feet back into the reel. Pull the cord out slowly-when a 'click' is heard, the cord will lock in place. Plug into wall outlet. **Figure 3**.
- C. To release the cord, unplug from wall outlet, and slowly pull cord out until clicking stops. The lock will release and the cord can be guided slowly back into the reel. ***DO NOT allow the cord to fly unrestricted back into the reel.***

Accessing Control Box & Power Strip

- A. To access the control box and power strip, remove the (4) thumbscrews. **Figure 4.**
 B. Remove the control box cover.

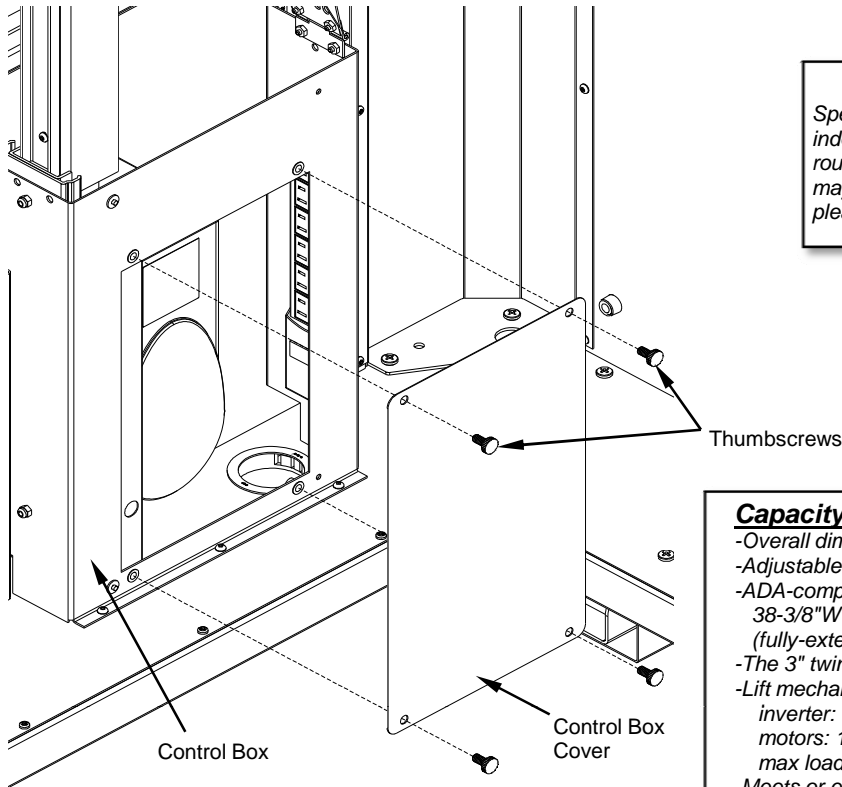

Figure 4

Designed For Indoor Use Only
 Spectrum carts and lecterns are designed and constructed for indoor use only. Moving or using outdoors or on excessively rough surfaces may cause damage to the cart or casters and may void the warranty. If an outdoor application is desired, please contact us to discuss potential custom design solutions.

Capacity
 -Overall dimensions: 48-3/8"W x 30"D x 43-1/16"H (fully-extended)
 -Adjustable worksurface height: 28"-40"H
 -ADA-compliant knee and leg clearance:
 38-3/8"W (without CPU) x 22-1/2"D x 39"H
 (fully-extended without pull-out worksurface)
 -The 3" twin-wheel swivel casters have a total load rating of 660 lbs
 -Lift mechanism:
 inverter: 120V @ 60Hz, max output 400 watts, 3.3 amps
 motors: 18V / 10 amps
 max load: 800N (180 lbs)
 -Meets or exceeds all ANSI-BIFMA test standards
 -**Unit weight:** 260 lbs
 -**Shipping weight:** 310 lbs (approx)

Freedom Lectern Options

