

Doctorate Lectern (SMART® compatible)

55245TW - w/ 3" Twin-Wheels

55244TW - w/ 3" Twin-Wheels (no worksurface cut-out)

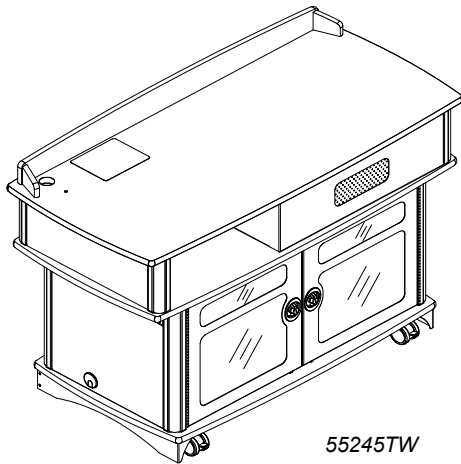

55245TW

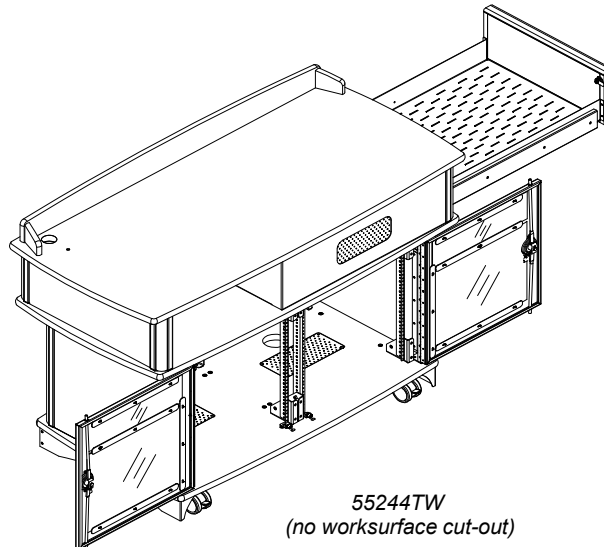

55244TW
(no worksurface cut-out)

The Doctorate Interactive Lectern is a SMART® compatible lectern designed to effectively work with all the latest in interactive presentation technology. Loaded with standard features, the Doctorate Lectern is spacious enough to house a wide variety of multimedia equipment.

Features and Benefits

- Pull-out locking drawer (with vented bottom) on full-extension ball bearing drawer slides provides security and quick access to a document camera
- Worksurface cut-out fits an Extron® Cable Cubby 800™ (cover plate included)
- Also available in a version without worksurface cut-outs for custom equipment installations by integrators or end-users
- Scratch and impact-resistant 1¹/₁₆" high-pressure laminate worksurface
- Optional pull-out adjustable keyboard tray provides convenient keyboard access
- Dual-bolt, keyed locking front doors provide security and easy-access
- Removable back panels provide security and easy-access to rear of unit making it easy to maintain audio, video, and multi-media equipment
- Removable acrylic front door panels allow access to a DVD player or other devices without opening the door
- Four 3" swivel, locking twin-wheels
- Ventilated internal and side panels keep equipment cool
- Worksurface and internal grommets keep wires and cords manageable
- Worksurface has ample room for papers, laptops, projectors, and most peripheral equipment
- Solid hardwood worksurface surround provides privacy and styling
- Front and rear rack-rail equipment mounting and enough storage space for an internal tower CPU
- Dual-position rack rails can be moved further inside the unit to accommodate larger knobs and plugs
- Guaranteed to be free of all defects in materials and workmanship with a 10-year warranty

Construction

- The worksurface and base panel are constructed from 1¹/₁₆" thick industrial-grade composite board with .030 high-pressure laminate on one face, and a balancing phenolic backer on the opposing face
- Metal components consist of 16 and 20-gauge steel
- Vented panels are made of 20-gauge steel
- All metal components are finished with a scratch-resistant powder coat epoxy
- Worksurface and base panel edges are finished with a laminated/solid wood core
- Clear acrylic viewing panels
- Solid wood corner trim and surround
- Each Doctorate Lectern is factory-assembled, packaged, and shipped on its own skid

Capacity

- Overall dimensions: 60"W x 28¹⁵/₁₆"D x 43¹/₈"H
- Worksurface height: 38¹/₂"H
- Internal dimensions: 45³/₄"W x 25"D x 21⁷/₈"H
- The Extron® Cable Cubby 800™ cut-out is 7.860"W x 6.320"D
- Four sets of standard rack rail provide 12RU each (front and rear mounted) (Total of 48RU)
- Pull-out document camera drawer is 20⁷/₈"W x 29¹⁵/₁₆"D x 8³/₈"H (top-to-bottom clearance)
- Keyboard compartment: 20¹/₈"W x 26"D x 9¹/₄"H
- The 3" twin wheels have a weight capacity of 165 lbs each (660 lbs max total unit weight)
- Meets or exceeds all ANSI-BIFMA test standards
- **Unit weight:** 316 lbs
- **Shipping weight:** 427 lbs

Color Options

Standard laminate / Color combinations:

- Wild Cherry / Black (CHB)
- Indigo Organix / Dark Grey (ID)
- Fusion Maple / Black (FMB)

Standard color combination refers to the quickest deliverable product color combination. Custom laminates and color combinations are available-additional lead-times and up-charges may apply. Call 800-235-1262 for further information.

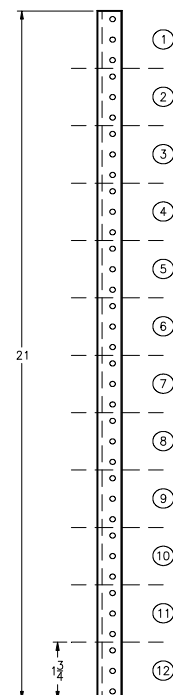

Doctorate Lectern Rack Rail
(12 Rack-Units available)

55245TW
Doctorate Lectern
 (shown with optional keyboard tray)

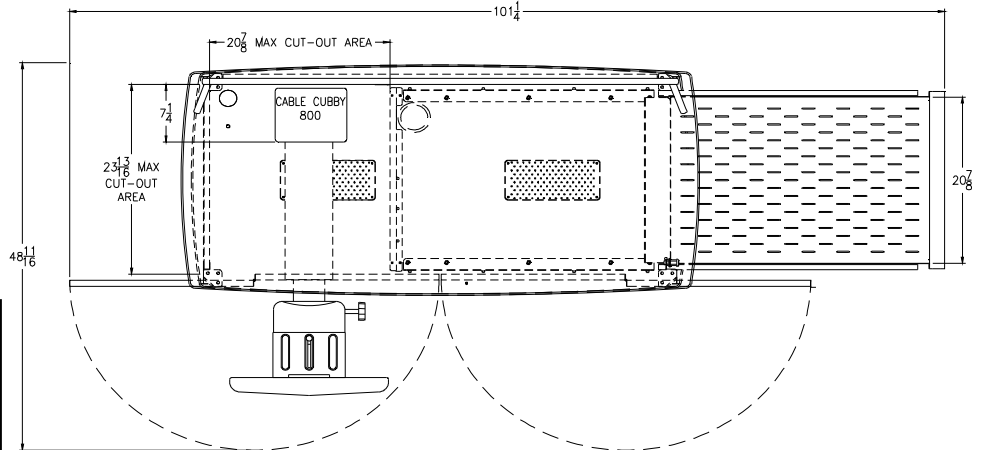

Note: Modified worksurface cut-outs should be reviewed by Tech Service to ensure clearance of brackets, keyboard slides, or other objects under the worksurface.

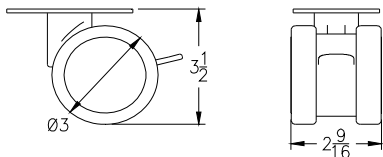
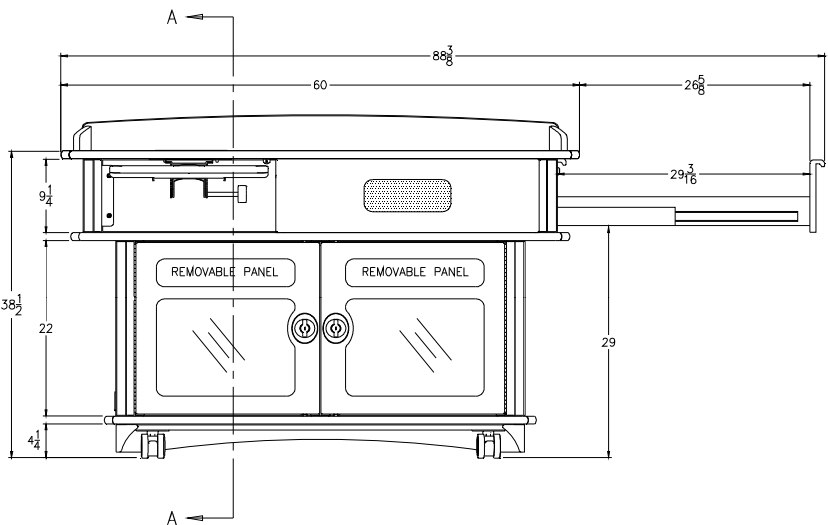
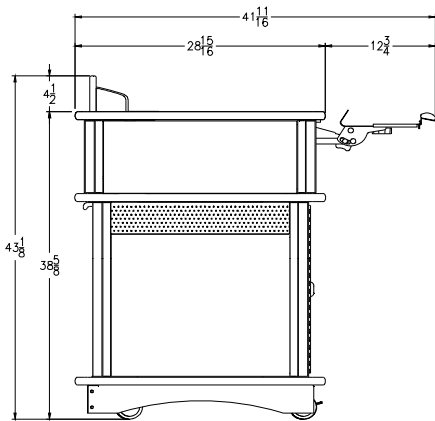

3" twin-wheels

Note: On multiple carts, drawer and door locks can be keyed the same or differently. A modification can be made to key the locks on a single cart differently or to key all the carts differently. An up-charge and lead-time will apply. (Standard locks are all keyed the same.)

Designed for indoor use only
 Spectrum carts and lecterns are designed and constructed for indoor use only. Moving or using outdoors or on excessively rough surfaces may cause damage to the cart or casters and may void the warranty.
 If an outdoor application is desired, please contact us to discuss potential custom design solutions.

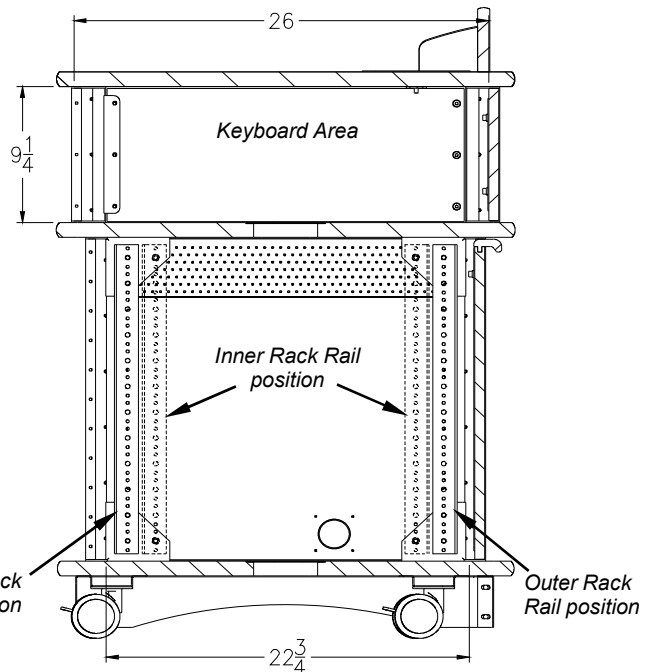

'A-A' Section View

Doctorate Lectern Options

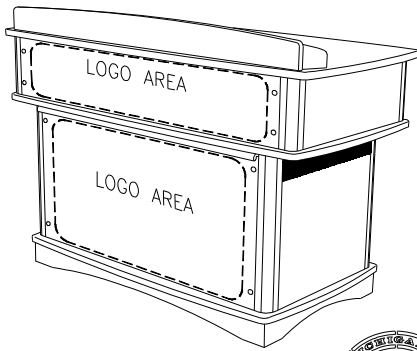

Custom-Cut Logo
(Typical logo location-
shown on student-side)
55141

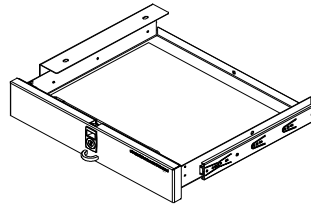

Keyboard Drawer w/ Flip-down front
18³/₄"W x 16"D
(Keyed the same as Doctorate
drawer and front door)
55247

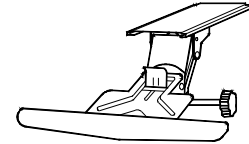

Adjustable Keyboard Tray
18³/₈"W x 12"D
95511

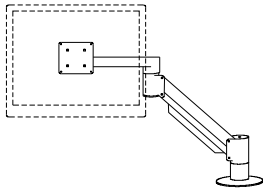

Flat Panel Monitor Arm
95512 (for monitors weighing 4-14.5 lbs)
95522 (for monitors weighing 9-24 lbs)
95509 (for monitors weighing 12-29 lbs)

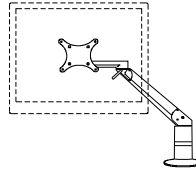

Evo Flat Panel Monitor Arm
95523 (for 15"-19" monitors weighing 6-13 lbs)
95524 (for 19"-21" monitors weighing 13-21 lbs)

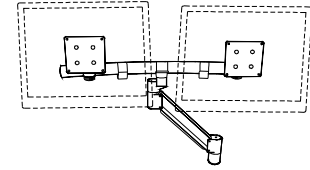

Dual Flat Panel Monitor Arm
(23" max center-to-center distance)
(4-19 lbs per monitor)
95516

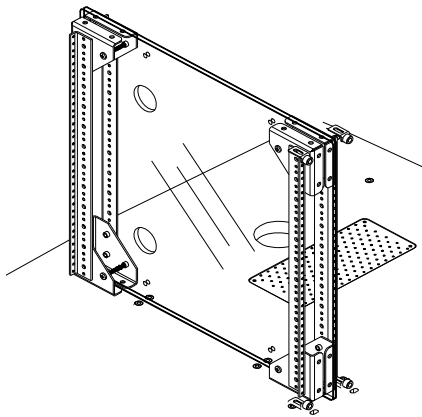

Clear Acrylic Security Panel
55246

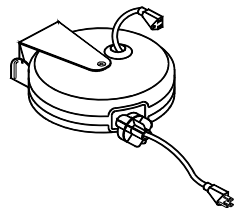

15' Retractable Cord Reel
(inboard-mounted) (15-amp)
99029

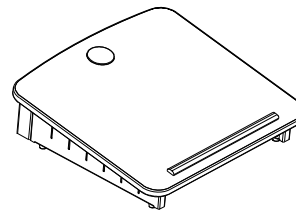

Riser Podium
18"W x 17³/₁₆"D
95002

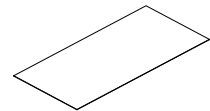

Non-Slip CPU Pad
11"W x 23"D
95518

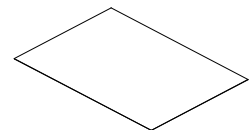

Non-Slip Pad
24"W x 17"D
95508

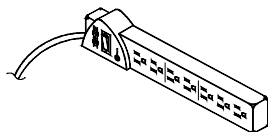

7-Outlet Power Strip, insured
w/surge protector, bracket, and 12' cord
10"W x 2"D x 1¹/₈"H
99024

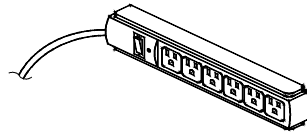

6-Outlet Power Strip
w/ 12' cord
11⁵/₁₆"W x 1¹/₁₆"D x 1³/₁₆"H
99023



Replacement Key Set
for dual-bolt lock
55142

Replacement Key Set
for camera drawer
55143

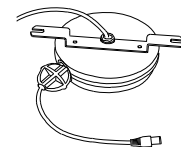

Data Cord Reel
w/ 14' CAT 5 cord & plugs
99026

Rack-mount accessories

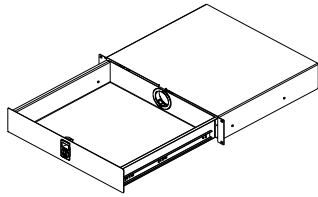

Locking Drawer (3RU)
interior dims: 15³/₄"W x 13¹/₁₆"D x 2⁷/₈"H
(25 lbs max load)
97514

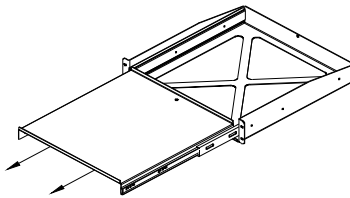

Pull-Out Shelf (2RU)
16¹/₂"W x 17³/₄"D
(50 lbs max load)
97505

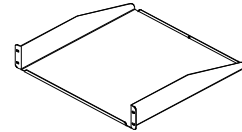

Cantilever Shelf (2RU)
17¹/₂"W x 18"D x 3¹/₂"H
(50 lbs max load)
97504

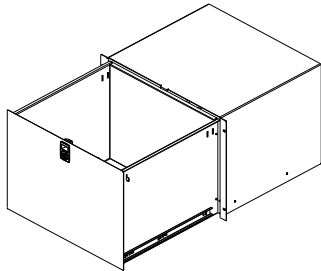

Locking File Drawer (8RU)
includes file holder
interior dims: 15³/₄"W x 13⁹/₁₆"D x 13⁵/₁₆"H
(50 lbs max load)
97515

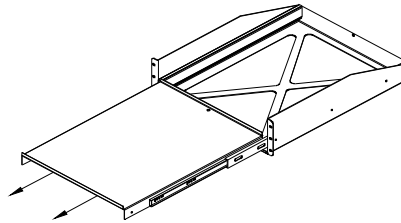

Pull-Out Shelf (3RU)
16¹/₂"W x 21³/₄"D
(80 lbs max load)
97503

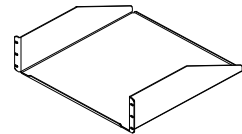

Cantilever Shelf (3RU)
17¹/₂"W x 18"D x 5¹/₄"H
(80 lbs max load)
97502

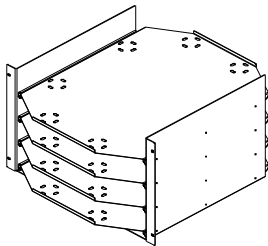

LT-4 Laptop Storage Unit (7RU)
(stores 4 laptops horizontally)
laptop tray dims:
16¹/₄"W x 20¹/₂"D x 2³/₁₆"H
97517

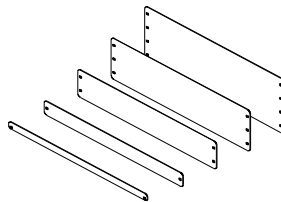

Rack-Mount Blanks
(fills rack spaces where
components are not needed)
97516 - (1/2RU)
97510 - (1RU)
97511 - (2RU)
97512 - (3RU)
97513 - (4RU)

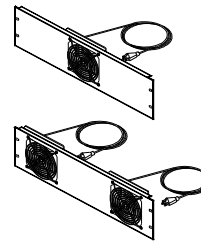

Cooling Fans (3RU)
19"W x 2"D x 5¹/₄"H
Single Fan-97507
Double Fan-97506

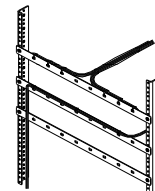

Wire Lace Kit
3 Lace Straps included
95517

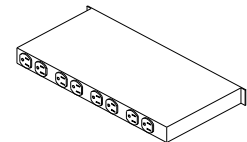

9-Outlet Power Strip (1RU)
19"W x 9"D x 1³/₄"H
99021