

Assembly Instructions

⚠ Important ⚠

Before you begin, read and comply with all safety and operating instructions, and ensure all parts and correct quantities are included.

Any parts damaged during shipment must be reported within 5 days of receipt. To report information regarding missing parts or damage, to purchase parts or accessories, or if you have any questions, please contact us.

www.spectrumfurniture.com
800-235-1262, 715-723-6750

Thank you for purchasing Spectrum products!

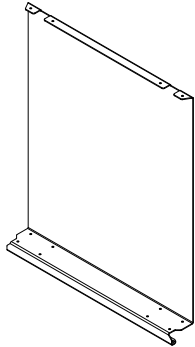

(2) 0154887
Rack panel

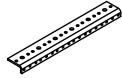

(4) 058516
Rack rail (10.5")



(14) 0100167
8-32 x 1/2" PH
thread-cutting
screw

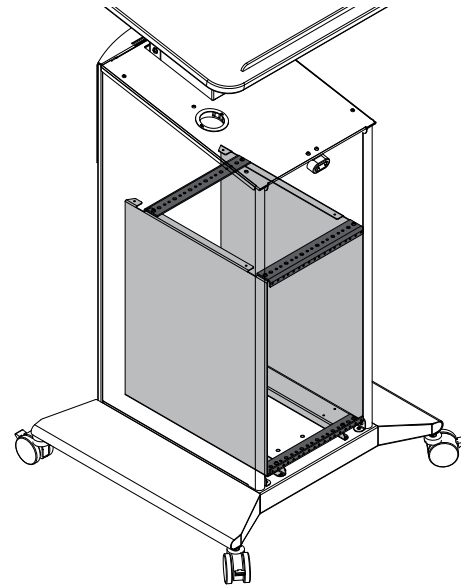

6RU Adjustable Slim Rack Cube for Slim Lecterns

97525



1. Assemble rack cube

1. Align the rack panels, four rack rails, and brackets as shown. Note two positions available on audience-side for Slim, or Slim adjustable lectern. **Figure 1.**
2. Assemble with (12) 8-32 x 1/2" PH thread-cutting screws.
3. Tighten screws securely.

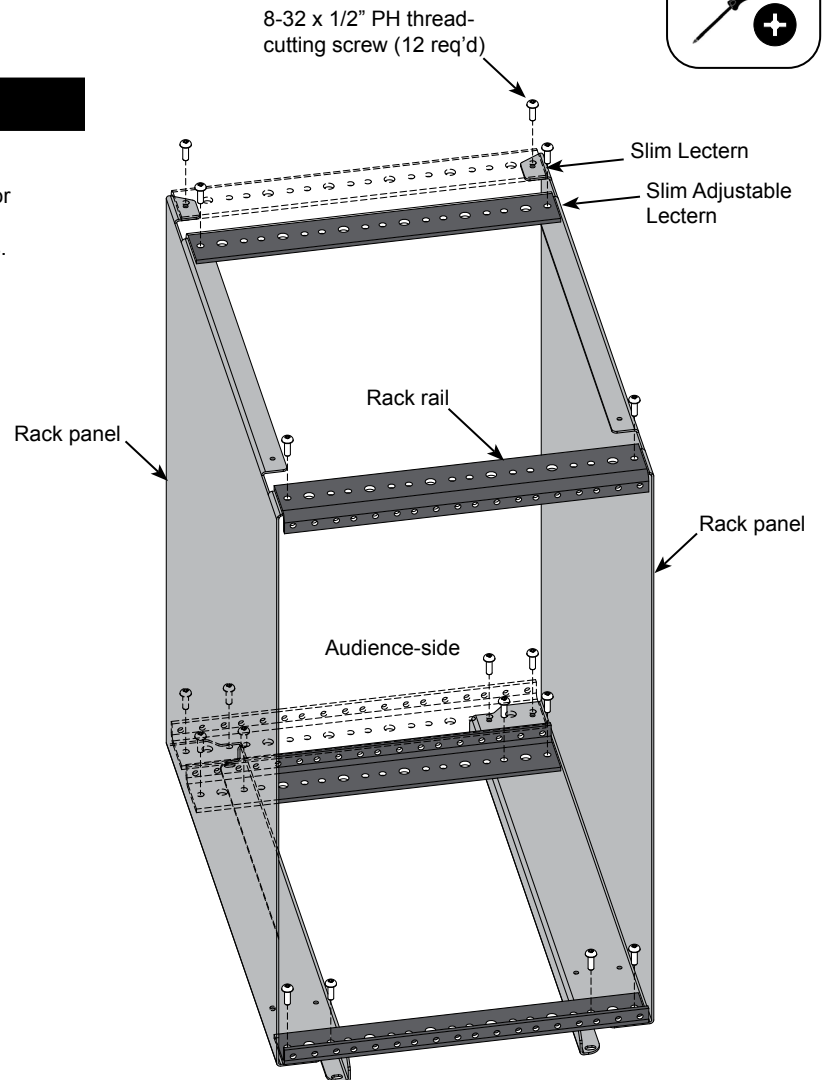

Note: Do not tighten fasteners completely until all have been installed. Keeping them loose will help with alignment during assembly.

2. Install rack cube

1. Place the rack cube assembly onto the base panel of lectern. **Figure 2.1.**
2. If the cube needs to be secured to the lectern, remove the audience-side panel. (Lift up, then out). **Figure 2.2.**
3. Align with the mounting holes in the base panel and use (2) 8-32 x 1/2" PH thread-cutting screws (1 through each bracket) to secure to base panel. **Figure 2.3.**

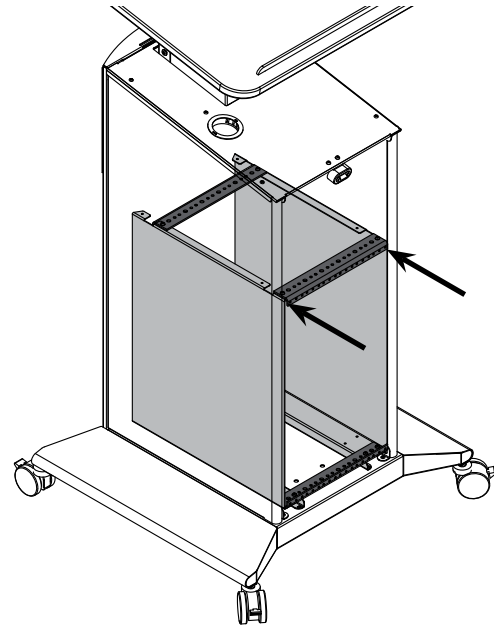

Figure 2.1

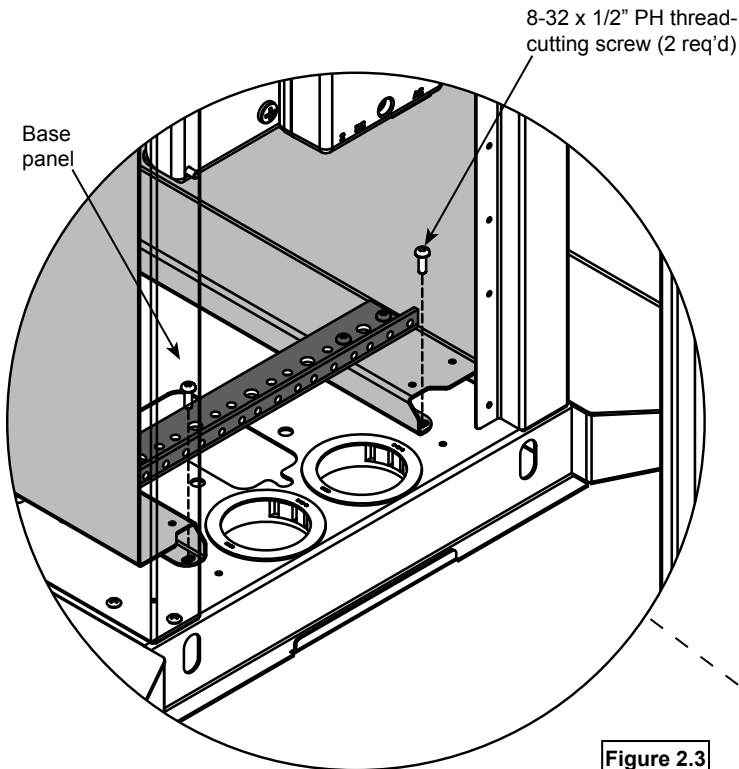

Figure 2.3

Note: The rack cube provides 6RU of rack space and is easily removed from the lectern. This simplifies installation of equipment and provides the ability to integrate equipment remotely. The cube can be installed into the lectern at a later date or when convenient.

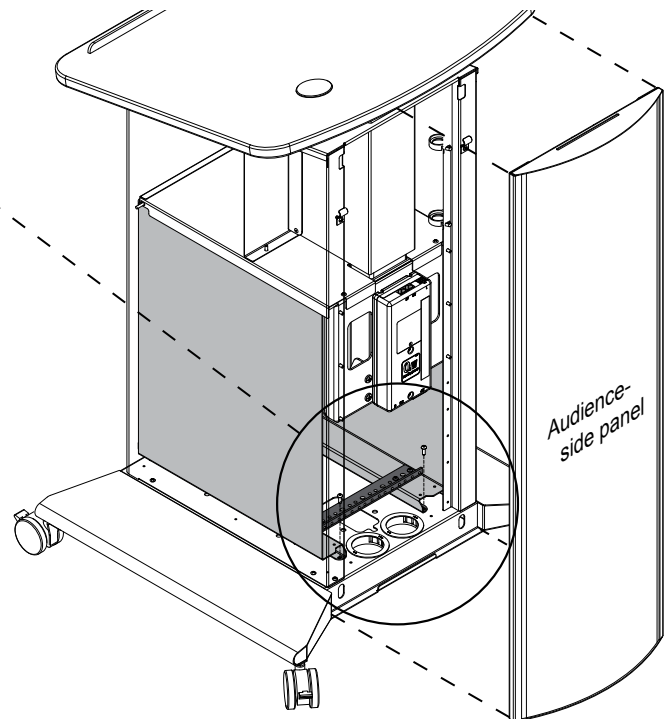

Figure 2.2