

Assembly Instructions



Important

Before you begin, read and comply with all safety and operating instructions, and ensure all parts and correct quantities are included.

Any parts damaged during shipment must be reported within 5 days of receipt. To report information regarding missing parts or damage, to purchase parts or accessories, or if you have any questions, please contact us.

www.spectrumfurniture.com

800-235-1262, 715-723-6750

Thank you for purchasing Spectrum products!



(8) 026064
1/4-20 x 5/8"
PHMS



(6) 0100167
8-32 x 1/2"
PH thread-cutting
screws



(2) Rack rails
36" - 044922
42" - 050067

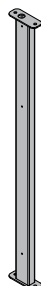

(2) Rail supports
36" - 052434
42" - 053099

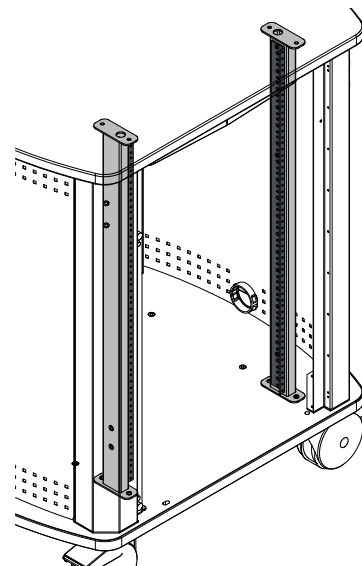

Rear Rack Rail Kit for LINK Lectern

55134 - 36" LINK

55139 - 42" LINK

1. Attach rail supports

1. Rail supports can be mounted in an inner or outer mounting position. (The inner position can be useful if the rack rail equipment has large knobs or controls-the outer position should be used when maximum equipment depth is necessary.)
2. Position the rail supports as shown. **Figure 1**. (The 3 pre-drilled holes will face inward.)
3. Attach the supports to the LINK with 1/4-20 x 5/8" PHM screws and tighten securely.

Tools
Required



Phillips
screwdriver



Drill with #1
Phillips driver

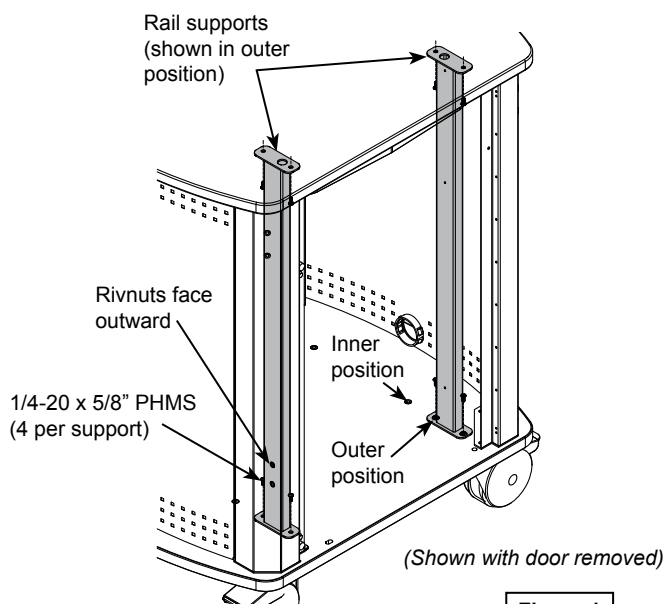

Figure 1

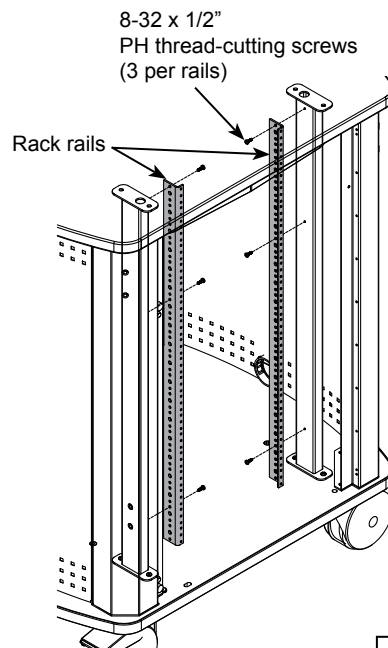

Figure 2

2. Attach rack rails

1. Position each rack rail with the short leg pointing inward as shown. **Figure 2**. Align the top hole of each rack rail with the top mounting hole in each rail support.
2. Using an electric drill with a #1 Phillips driver, attach each rail to the rail support with (3) 8-32 x 1/2" thread cutting screws. Tighten securely, but be careful not to strip out the holes. If equipped, a drill torque setting can help facilitate attaching the screws.