

Technical Specifications

55546



Put art into motion with the STEAM Roller Teacher Station! With 24 multi-color storage bins, you'll have room to store and transport everything you need to create an efficient mobile science, technology, or art-based teacher station. Label your bins to help organize your supplies and disperse throughout the room to help students maintain social distancing guidelines. Keep technology and valuables secure in the lockable storage cabinet. Located near the base of the cart, it keeps valuables out of the way and lesson materials more accessible at a higher location. Stay connected and keep technology charged throughout your day with the optional Cord Reel. The worksurface has ample space to utilize a laptop and keep it safe from spills with the built in cup holder.

Features and Benefits

- (14) Tote bins, and (10) Project totes maximize storage and organization options
- Convenient handle provides optimal control and maneuverability
- Double bolt lock, keyed, locker door in heavy-gauge steel keeps valuables safe and provides access to optional cord reel power
- The front lip above the locker shelf helps keep water jugs and other art supplies from sliding off the cart and spilling during use
- Deluxe 5" balloon wheels provide best-in-class mobility and lock to prevent movement when in session
- Scratch and impact-resistant high-pressure laminate top provides a durable, useful worksurface for instructor
- Handy, built in worksurface cup holder
- Powder coated, heavy-gauge steel construction is built to last
- Available in Steel Mesh laminate and Warm Gray metal
- Optional tote lids help keep projects and materials organized
- Optional cord reel with 15' cord provides convenient, temporary access to power to keep laptops, tablets or phones charged and ready
- Ships KD (knocked-down) and requires assembly
- Warranted to be free of all defects in materials and workmanship for 10 years
- Designed and assembled in Chippewa Falls, WI, USA

Color Options

Metal



Warm
Gray

Laminate



Steel
Mesh

Construction

- The top and base panels are constructed from 3/4" thick composite board with .030" high-pressure laminate on one face, and a balancing phenolic backer on the opposing face.
- Metal components consist of 20-gauge steel
- Top and base panel edges are covered with 3mm vinyl
- All metal components are finished with a scratch-resistant powder coat epoxy
- Each unit is shipped KD (knocked-down) and requires customer assembly.

Specifications

Capacity	14 tote bins, 10 project totes
Locking storage bin area (nominal)	9.625"W [24.4 cm] x 11.917"D [30.3 cm] x 4.853"H [12.3 cm]
5" Balloon Wheels	Weight capacity 300 lb [136.2 kg] each (two locking, two non-locking)
Certifications / compliance	Meets or exceeds applicable ANSI-BIFMA test standards
Unit weight (nominal)	108 lb [12.7 kg]
Shipping weight (nominal)	120 lb [13.6 kg]

Specifications subject to change without notice

Tote bins
(14 included)

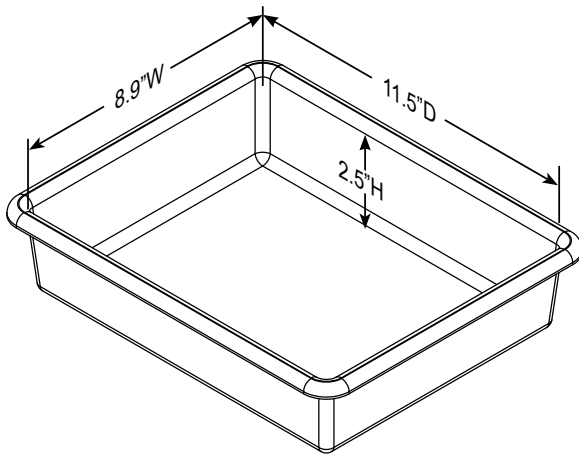

(internal dimensions shown)

Project totes
(10 included)

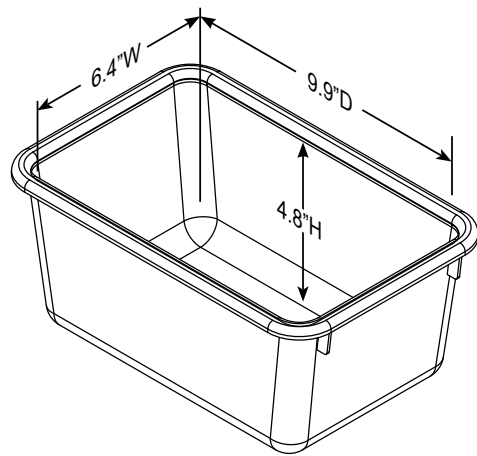

(internal dimensions shown)

- 10"W [25.4 cm] x 13"D [33 cm] x 3"H [7.6 cm]
- Internal area: 8.9"W [22.6 cm] x 11.5"D [29.2 cm] x 2.5"H [6.4 cm]
- Drop-resistant plastic
- Lids not included
- Unit weight (ea): .5 lb [.227 kg]

- 7.75"W [19.7 cm] x 12"D [30.5 cm] x 5"H [12.7 cm]
- Internal area: 6.4"W [16.18 cm] x 9.9"D [25 cm] x 4.8"H [12.3 cm]
- Drop-resistant plastic
- Lids not included
- Unit weight (ea): .5 lb [.227 kg]



Note: Mixed color cart includes:
(3) blue, (3) green, (4) yellow,
(4) red



Note: Mixed color cart includes:
(4) blue, (2) green, (2) yellow,
(2) red



55546-AAS1BL
Blue bins



55546-AAS1GR
Green bins



55546-AAS1RD
Red bins



55546-AAS1YL
Yellow bins



55546-AAS1
Multi-colored bins

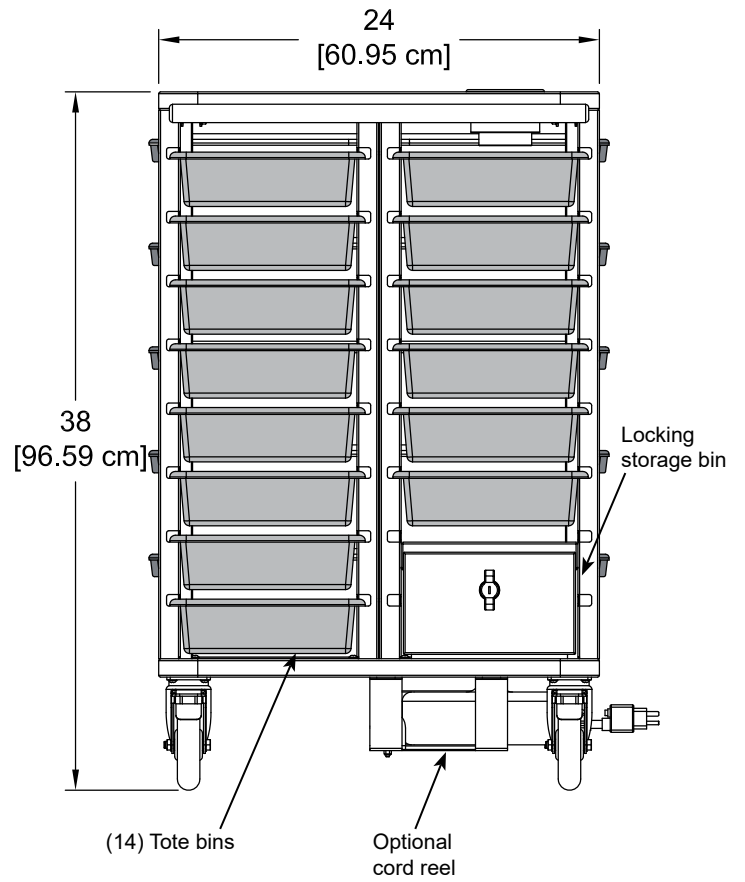
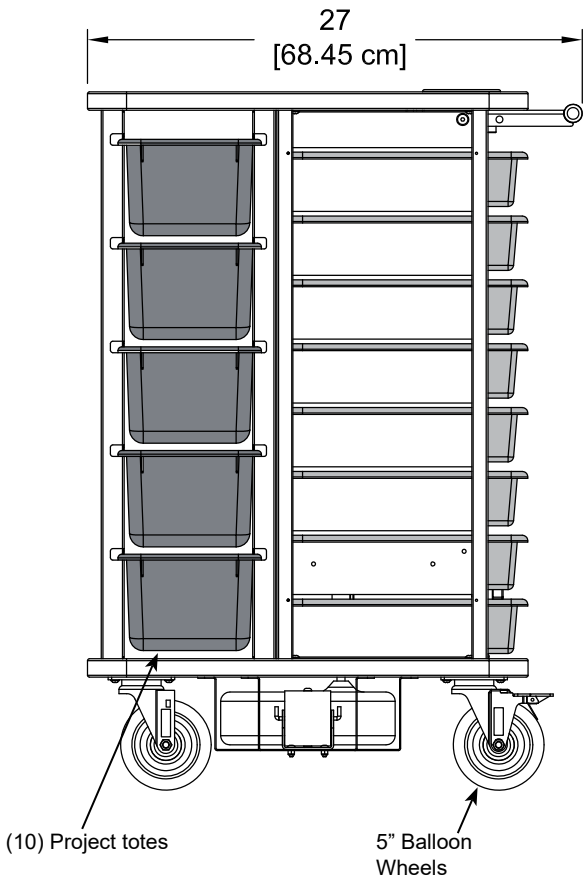
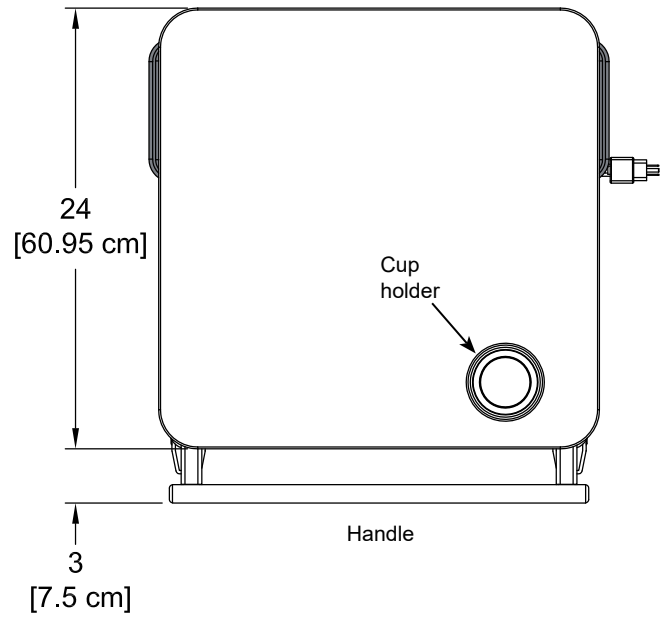

Accessories

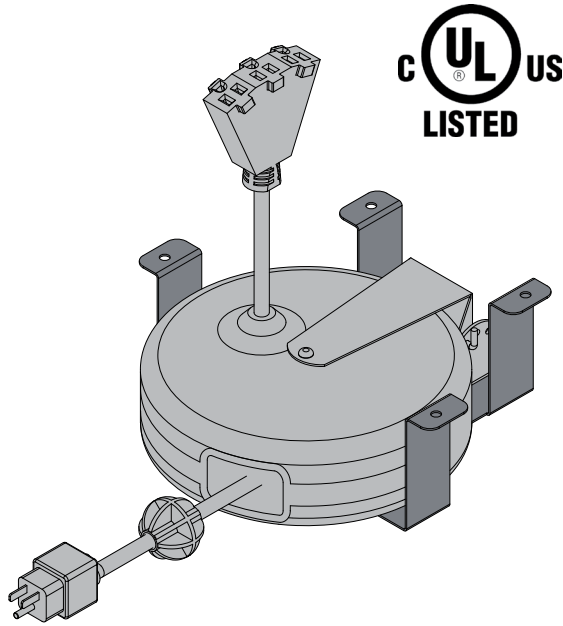

Cord Reel Kit - 99038

- Includes universal mounting bracket
- Mounts under base panel
- Adjustable ball stop and releasable cord-locking ratchet holds the cord at any length up to 15'
- cUL listed

Power cord:	15' nominal, 12 AWG retractable power cord
Power receptacles:	<ul style="list-style-type: none">• Molded 3-prong male plug with 15A breaker and reset button• Tri-tap (3-outlet) receptacle
Universal mounting bracket:	<ul style="list-style-type: none">• 16-gauge steel• Black powder coat• Includes mounting screws
Unit weight:	10 lb [4.5 kg]
Shipping weight:	10.8 lb [4.9 kg]

The cord reel is intended to provide temporary access to electrical outlets for Spectrum mobile cart and lecterns. Check local electrical codes prior to installation.

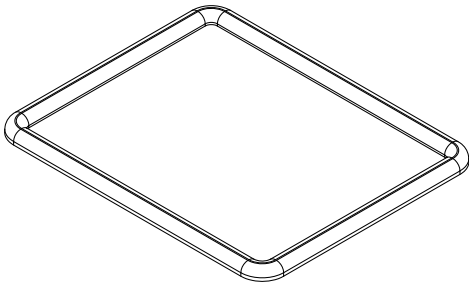

Lid Kit for Tote Bins

95007 - 5 Pack

95009 - 4 Pack

- Plastic lids for the project totes help keep projects and materials organized
- Available in 5 or 4 pack quantities
- Translucent drop-resistant plastic
- 10.85"W [cm] x 13.37"D [34 cm]
- Unit weight: .33 lb [.15 kg]
- Shipping weight: 2 lb [.9 kg]

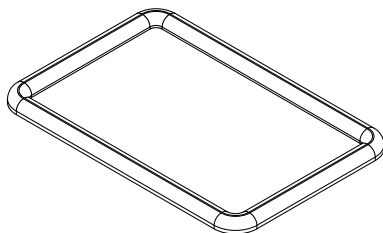

Lid Kit (5 Pack) for Project Totes - 95013

- Plastic lids for the project totes help keep projects and materials organized
- Translucent drop-resistant plastic
- 8"W [20.3 cm] x 12.3"D [31.2 cm]
- Unit weight: .33 lb [.15 kg]
- Shipping weight: 2 lb [.9 kg]

Warranty

We will make it right for you!

Thanks for choosing Spectrum! Spectrum is committed to provide complete customer satisfaction. Each of our products is manufactured from the best materials available and each product is stringently monitored throughout the production process through our P.A.C.E. program (Product Assurance to meet Customer Expectations).

We expressly warrant that Spectrum products will be of good quality and workmanship and free from defect for the period set out in the warranty from the date of delivery.

For a listing of all product specific warranty terms please visit our website at:

<https://www.spectrumfurniture.com/en/resources/purchasing-terms-warranty>

1-800-235-1262

Toll-free HELPLINE

spectrum@spectrumfurniture.com