

Technical Specifications

55472

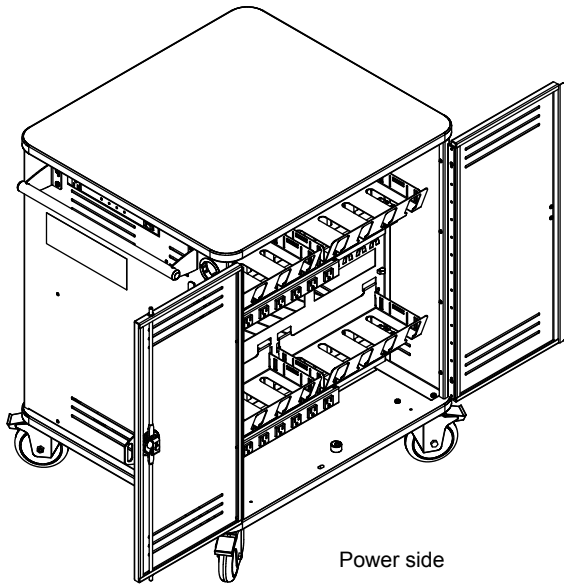

Power side

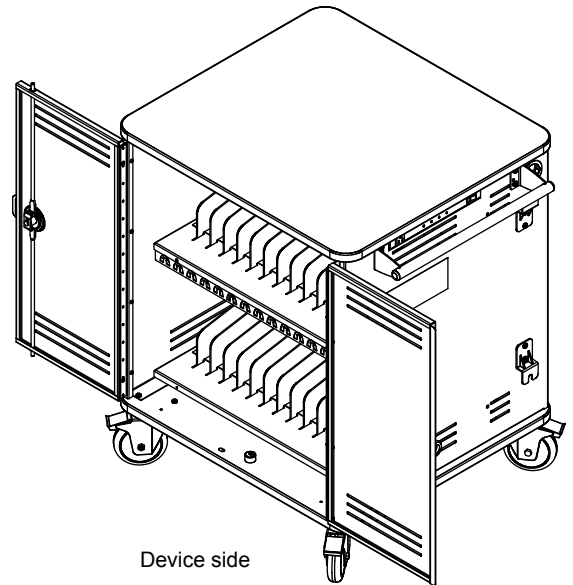

Device side

Use the Pro32 Cart to store, transport, and charge up to 32 notebooks or laptops. A current-sensing charger provides adaptive switching. Padded shelves and flexible dividers protect the notebooks. The overhead wire management aids the wiring integration and allows the charging plugs to hang in front of each laptop. The cart's compact footprint and handle provide easy mobility. The Pro32 Cart is made with heavy-gauge steel for security and powder-coated for a durable, long-lasting finish. A dual-bolt lock with hasp on the doors increase security of the notebooks.

Features and Benefits

- Stores, charges, and transports up to 32 of the largest notebooks (laptops) commonly used in education
 - 1.625"W x 17.375"D x 12.4375"H storage bay
 - Small cart footprint (30.75"W x 28"D) saves valuable space
 - Durable ABS plastic dividers and shelf padding protect notebooks from scratching (dividers are removable to provide storage space for thicker devices)
 - Dual doors provide easy access while reducing space necessary for swing radius
 - Double bolt keyed locks and heavy-gauge steel doors provide security
 - Hasp locks provide an additional level of security and the ability to use your padlocks of choice (not included), or secure the unit to a wall
 - Notebooks and students are separated from all line voltage
 - Superior, all-metal overhead cord management system keeps charge cords organized above each storage bay
-
- Intuitive PowerProdigy™ charging system senses current from up to four, 8-outlet power units and distributes power (up to 10A) to the least-charged notebooks first (where charging is needed most)
 - Four horizontally adjustable, 8-outlet, (125V~/12A, 60Hz) universal power units work with both inline, and wall adapters
 - External power switch provides easy-access for safe power connection / disconnection
 - 2 aux outlets (always on) for teacher laptop, WiFi access point, or other accessory (1 external, 1 internal)
 - Large, removable QuickBrick™ wiring trays with retaining straps for charge adapters allow wiring to be completed outside the cart at the comfort of a workstation or desk to provide quick and easy integration
 - Ventilated doors and side panels keep notebooks and chargers cool, preventing overheating, and extending device life
 - Replaceable, IEC quick-release 15' nominal 14 AWG, 3-wire power cord and external cord wrap brackets provide easy power access
-
- Four inboard 5" locking balloon wheel plate casters with metal construction and non-marring rubber provide easy rolling, and quiet transport (rated for 325 lb each)
 - One all steel handle provides control and maneuverability
 - Worksurface and base panel vinyl edging protects walls and furniture
-
- Cart ships fully-assembled with handle for quick, simple integration and deployment
 - Durable powder coated steel chassis provides a long-lasting finish
 - Scratch and impact-resistant high-pressure laminate top provides a durable, useful worksurface for instructors
 - ETL recognized (certified to UL 60950-1) in the US and Canada for the cart and electrical system
 - SCS Indoor Advantage Certified; meets or exceeds applicable ANSI-BIFMA test standards
 - Warranted to be free of all defects in materials and workmanship for 10 years, electrical system 2 years
 - Assembled in Chippewa Falls, WI, USA



Includes:
PowerProdigy™ charger

Base
BW - 5" Balloon Wheels (4 swivel)

Color Options

<u>Laminate:</u>		<u>Metal:</u>
White Fiesta		Silver Sparkle

Construction

- The worksurface and base panel is constructed from 1" NAUF (No Added Urea Formaldehyde) composite board with .030" high-pressure laminate on one face, and a balancing phenolic backer on the opposing face
- Worksurface and base panel edges are covered with 3mm vinyl edge band
- 16-gauge side panels, shelves, and doors
- All metal components are finished with a scratch-resistant powder coat epoxy
- This cart is factory-assembled, packaged, and shipped on its own skid

Specifications

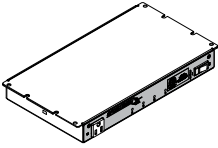
Capacity	32 Notebooks or Laptops	
Storage bays (nominal)	1.625"W [4.13 cm] x 17.375"D [44.1 cm] x 12.4375"H [31.6 cm]	
Electrical	<ul style="list-style-type: none"> • (4) 8-outlet power units (outlets rotated 90°) • 125V~/12A, 60Hz • 15-amp breaker • IEC quick-release (replaceable) 15' nominal, 14 AWG, 3-wire power cord 	<ul style="list-style-type: none"> • Locking power-side door isolates and separates electrical line voltage from students • ETL recognized (certified to 60950-1)
PowerProdigy™ Charger	 <ul style="list-style-type: none"> • Low-profile, 16-gauge steel enclosure • 125V~/12A, 60Hz • Externally-accessible 15A on/off switch • Smart charging senses current and distributes power to the power units requiring it most • Four timed power unit-dedicated outlets (labeled A, B, C, D) controlled by logic board (up to 10A power output) 	<ul style="list-style-type: none"> • Cycling interval 15 min • Four LED lights indicate charging activity status of each power unit • Two auxiliary outlets (1 external, 1 internal) 1A each (controlled by main on/off switch) • IEC quick-release (replaceable) 15' nominal, 14 AWG, 3-wire power cord • ETL recognized (certified to 60950-1)
5" Balloon Wheels	Weight capacity 325 lb [148 kg] each	
Unit weight (nominal)	208 lb [94.4 kg]	
Shipping weight (nominal)	240 lb [108.9 kg]	

Specifications subject to change without notice

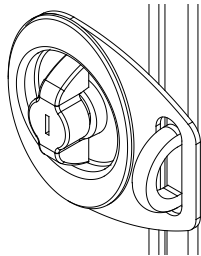

Double-bolt lock with padlock hasp (on both sets of doors) (padlocks not included)

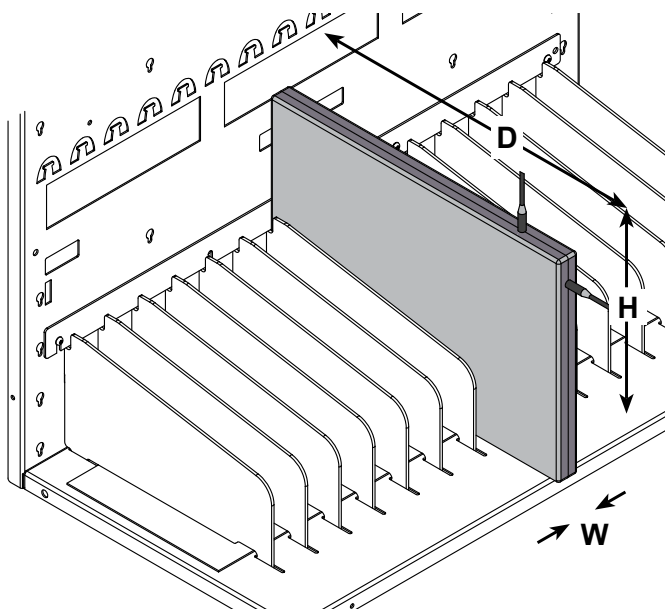

Notebooks / laptops must be placed in the bays with the charge plug on one of the two exposed edges shown.

5" Balloon Wheel (BW)

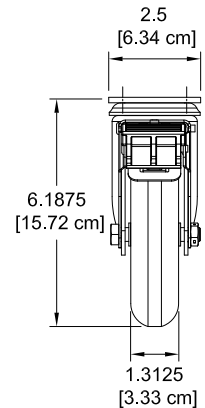
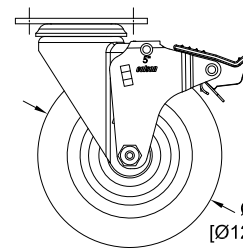
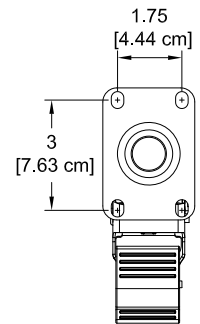
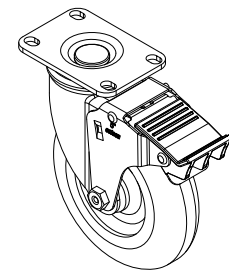

External power switch,
LED indicators, and
AUX outlet

Pro32
Notebook / laptop Cart

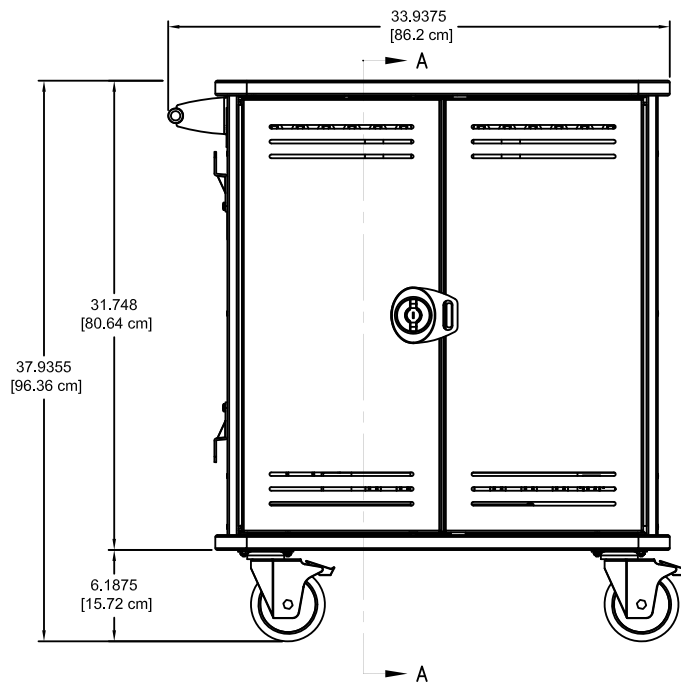
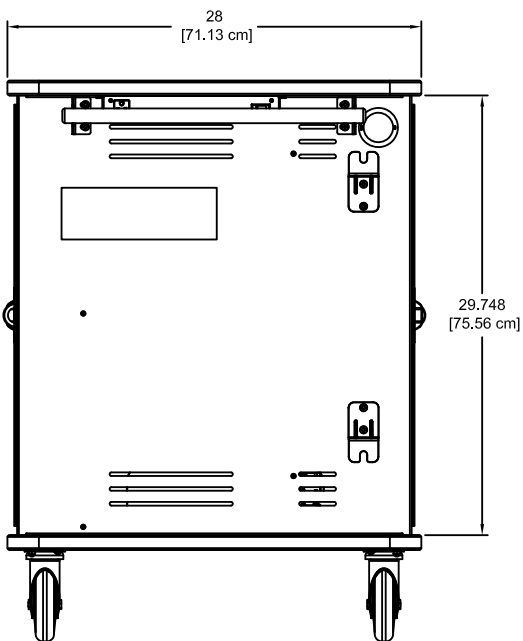
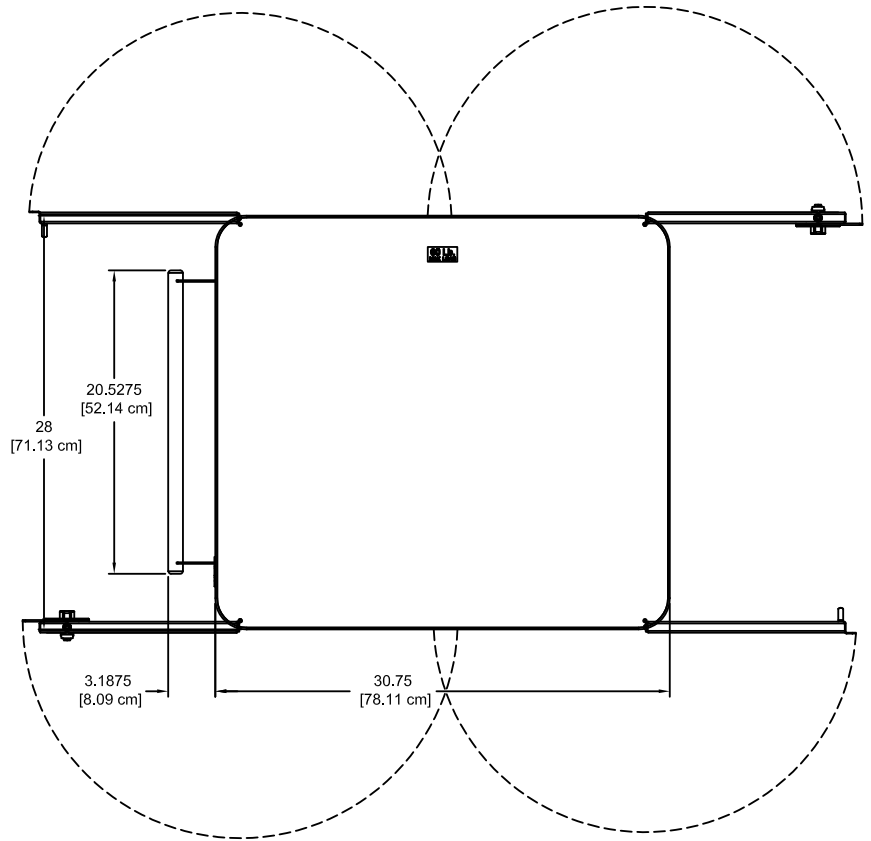
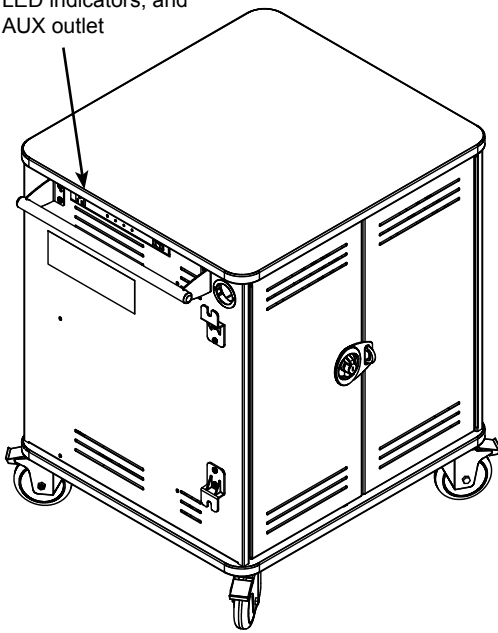

Pro32
Section view A-A

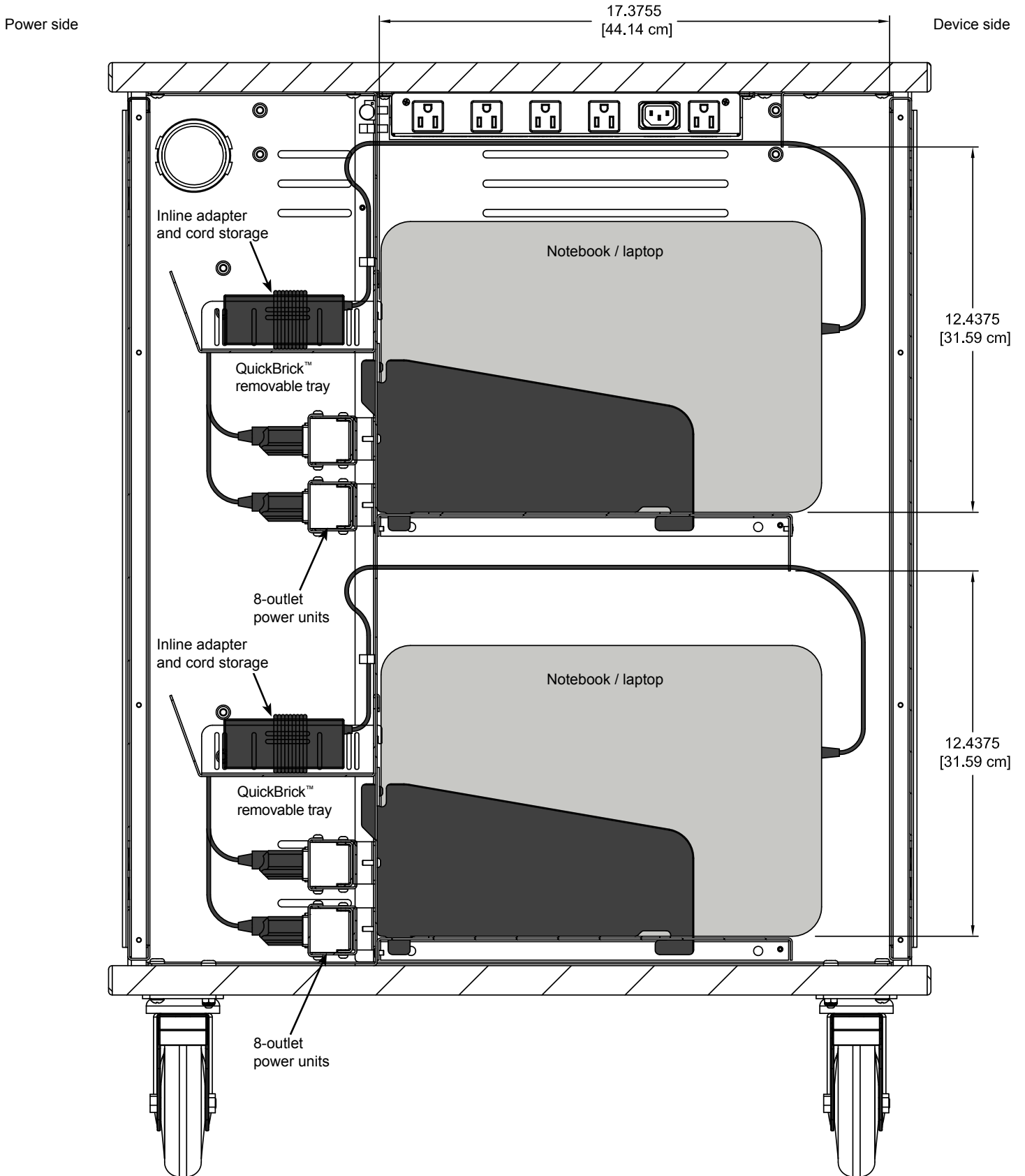

Pro32
Device side view wiring diagram
(shown without door)

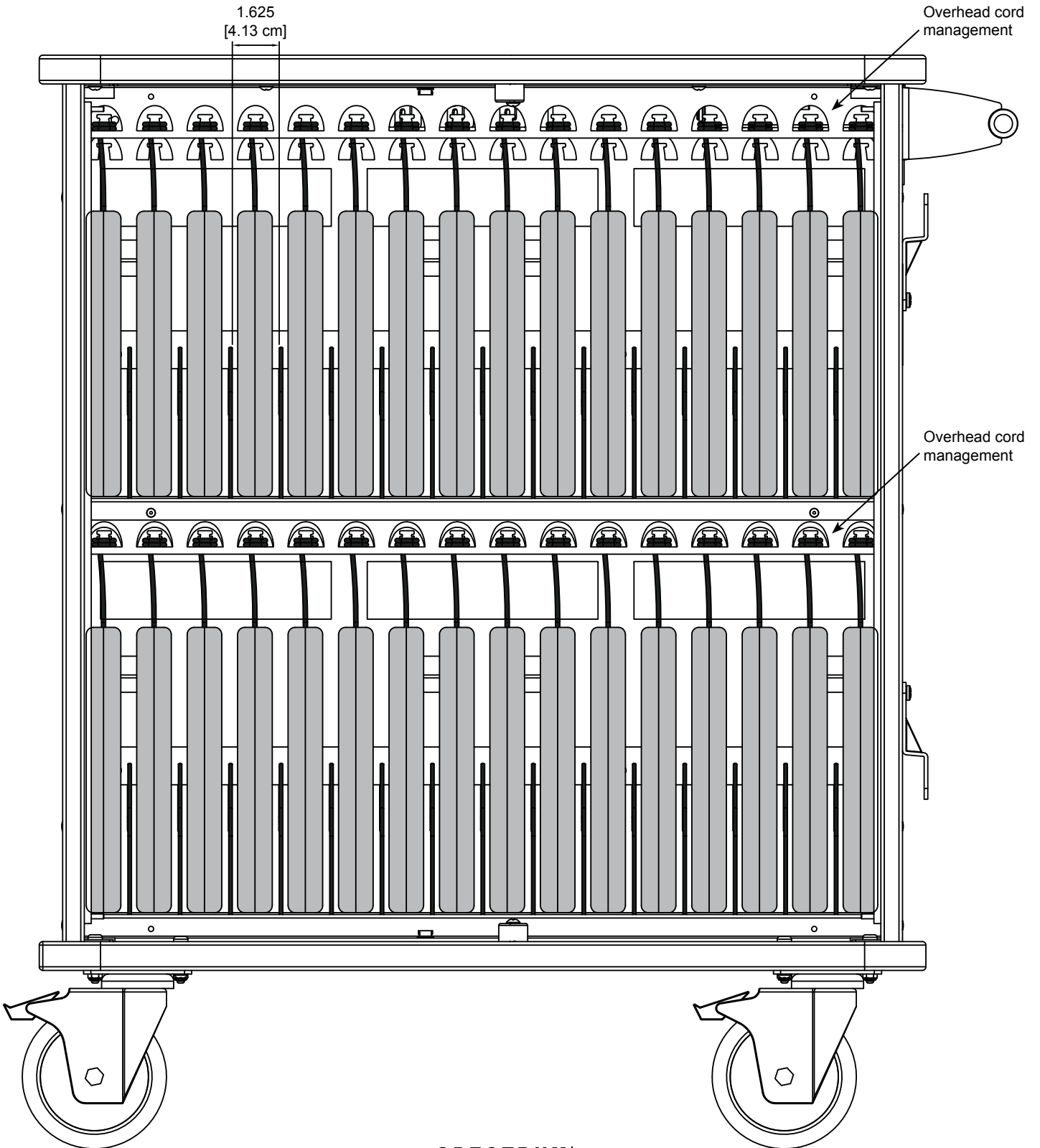

Pro32
power side wiring diagram and
power unit adjustability
(shown without door)

15' nominal [1m] 14 AWG,
3-wire IEC power cord
(to wall outlet)

39' nominal [1m] 14 AWG,
3-wire IEC power cord on
each upper power unit
(to PowerProdigy™ charger)

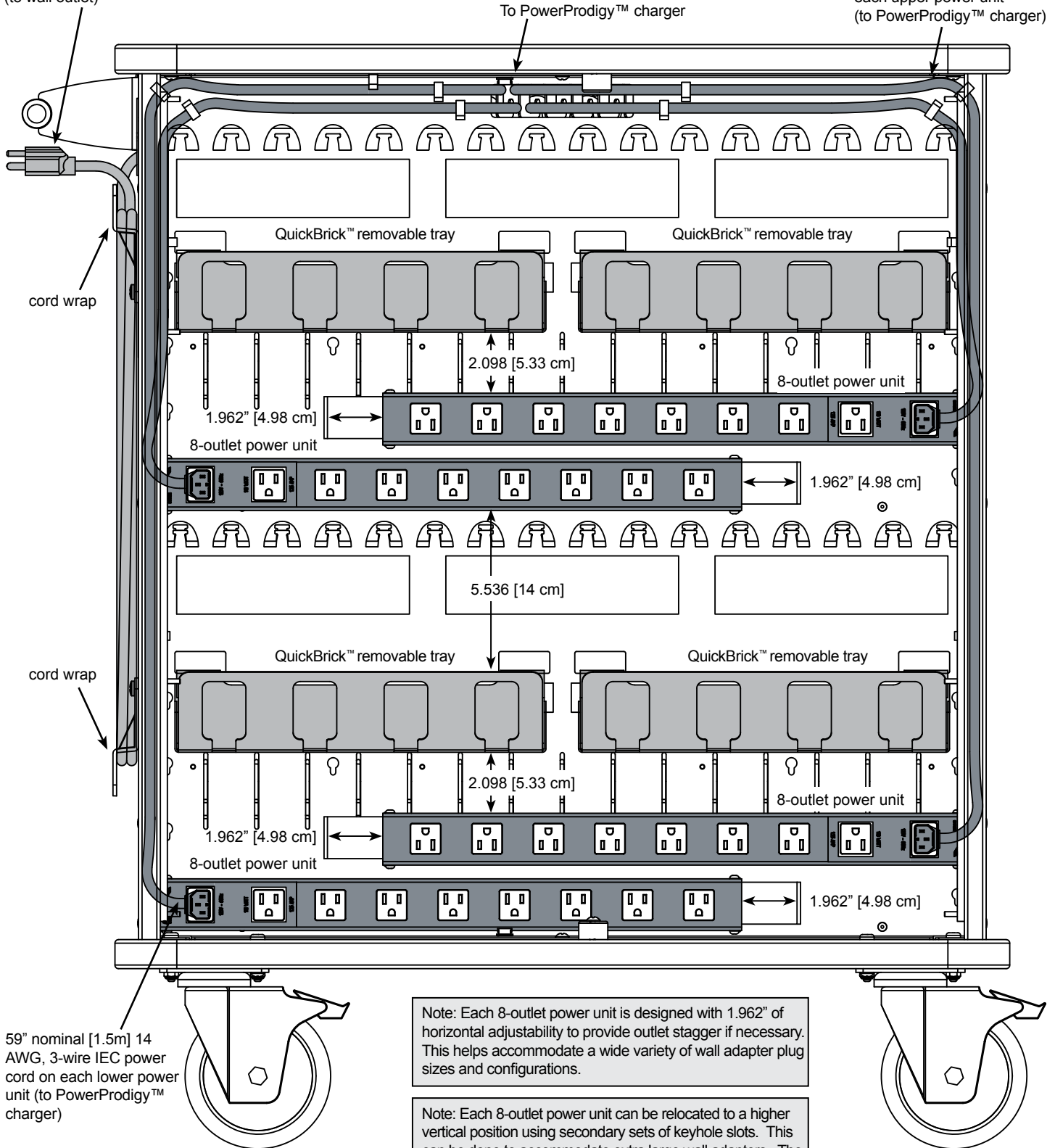

PowerProdigy™ Charger
(see p.9 for specs)

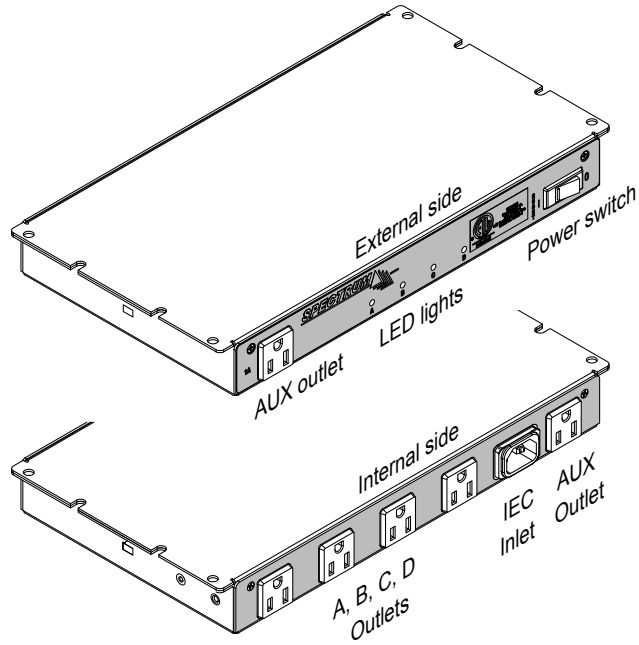

Nominal outlet spacing on
each 8-outlet power unit

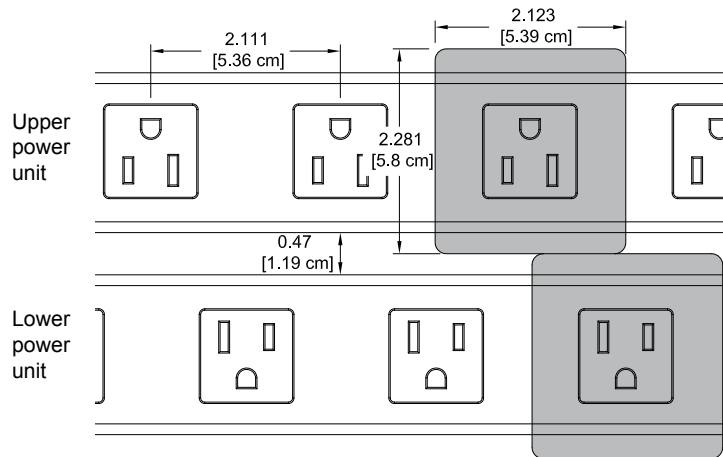

(See p.6 for spacing above and below outlets)

Pro32
Power unit vertical adjustability
(shown without door)

Note: Four sets of keyhole slots provide the ability to vertically relocate each 10-outlet power unit. This can be done to provide clearance for extra large wall adapters. Loosening two screws on each power unit allows easy adjustment. The QuickBrick™ trays are not needed and have to be removed in this configuration.

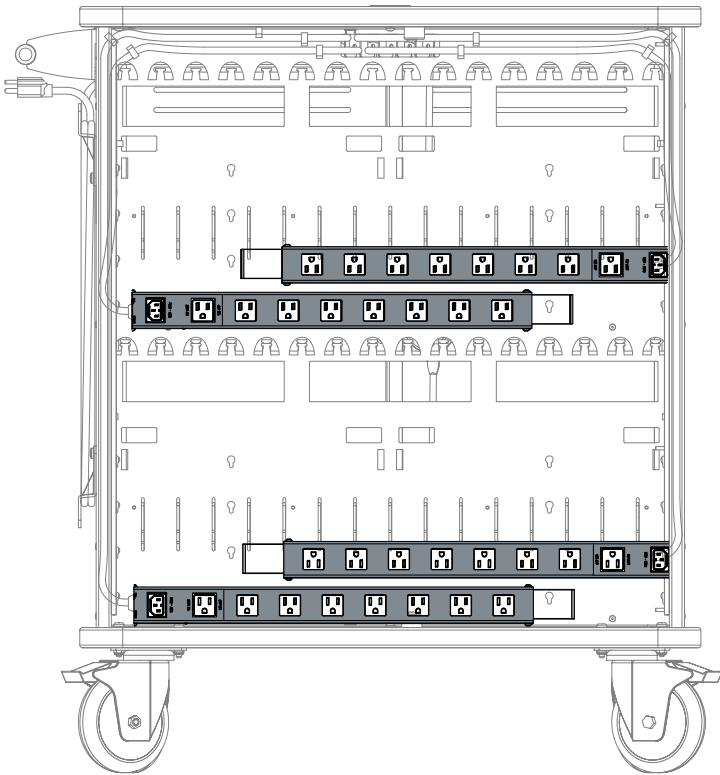
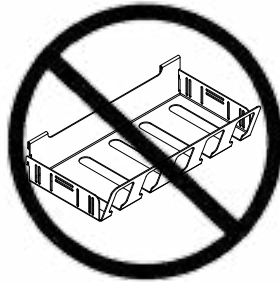
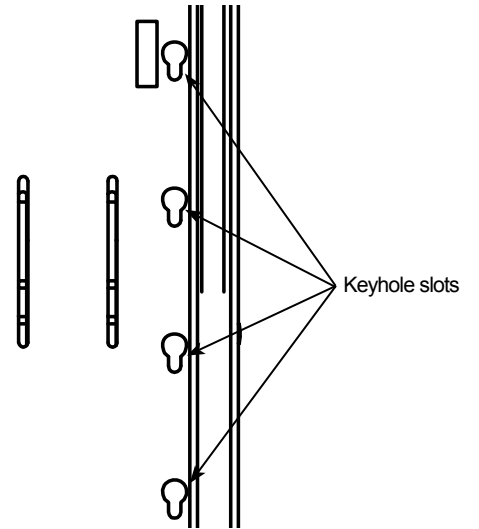

Factory-installed position

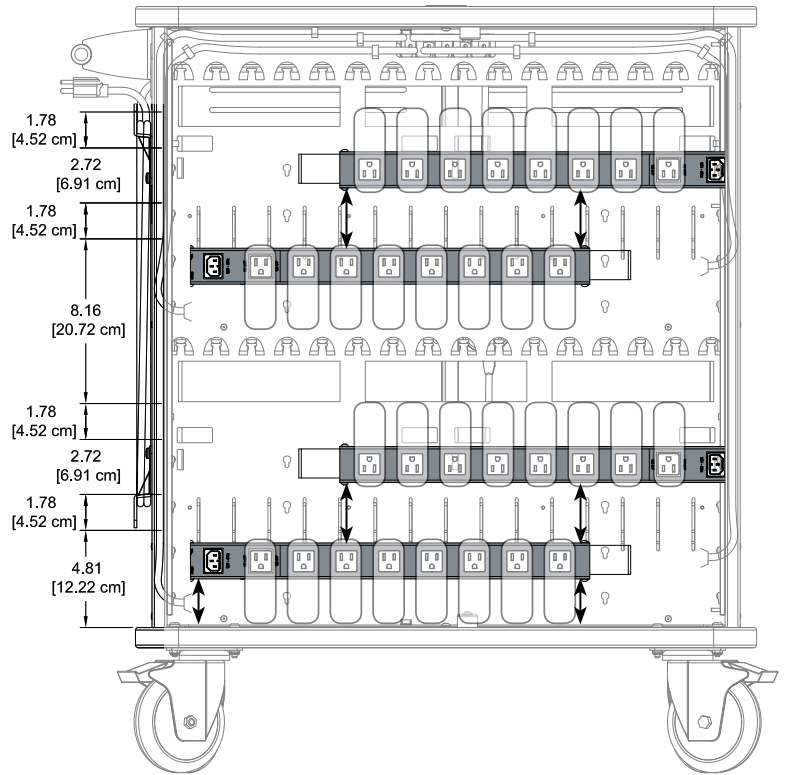

Typical spaced positions
for large wall adapters

PowerProdigy™ System

External side view
(external access)

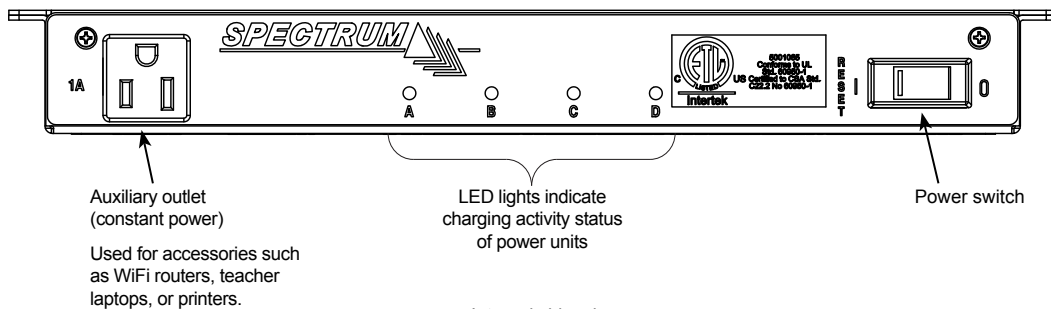

Internal side view
(internal access)

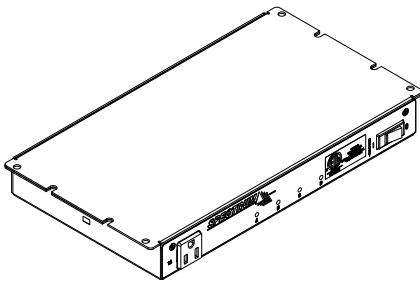
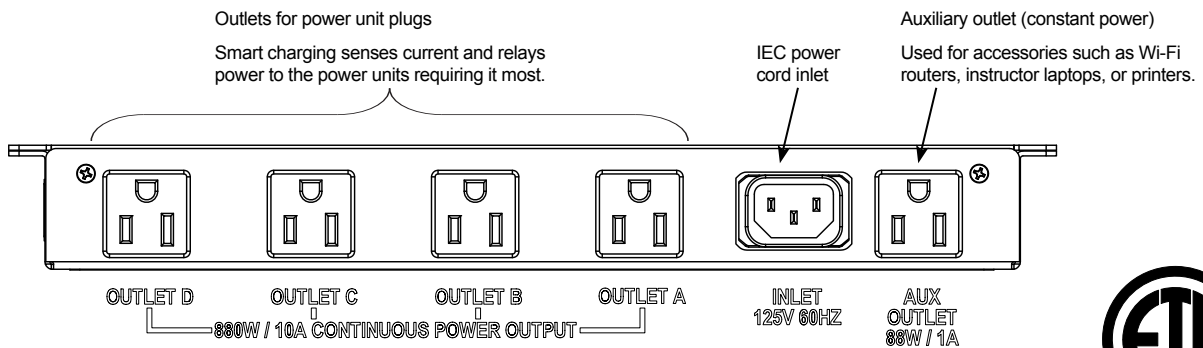

Specifications:

Input:	125V~/12A, 60Hz
Max output:	125V~/12A, 60Hz
Breaker:	15A, 250 VAC
Cycling Interval:	15 minutes
Cycling outlets:	4 timed internal (A, B, C, D) up to 10A
Auxiliary outlets:	1 external, 1 internal, 1A each (controlled by main on/off switch)
Power cord:	IEC quick-release (replaceable) 15' nominal, 14 AWG, 3-wire
Power switch:	15A, rocker, red-lighted
Indicator lights:	4 Green LED
Enclosure material:	16 gauge steel
Mounting type:	Screw / stud
Dimensions:	12.75"W [324mm] x 7.29"D [185.2mm] x 1.5"H [38.1mm]
Regulatory listing:	ETL recognized (certified to 60950-1)

Features:

- The PowerProdigy™ charger senses current from up to four, 10-outlet power units and distributes power (up to 10A) to the least-charged devices first. This sensing / switching occurs every 15 minutes. If no devices are plugged into a power unit, the charger skips that power unit and goes onto the next one.
- No adjustments by the user are needed
- If overall amp draw is low enough (below 10A), the charger will send power to all available power units
- Four LED lights indicate charging activity status of each power unit. Lights remaining on continuously indicate power is being provided to all four banks.
- Prevents electrical overload in older classrooms
- Diagnostic-capable mode
- 1A auxiliary outlets (one internal, one external) remain on while the unit is powered on, and can be used (even during charging cycles) to power accessories like a teacher laptop or WiFi access point
- External power switch

CAUTION

- **Auxiliary outlets are for peripheral use only.** Do not use auxiliary outlets to charge multiple laptops or devices. (Use cycling outlets A, B, C, D for charging.)
- Switch the timer power switch OFF before unplugging or plugging-in the main power unit cords
- Total equipment load not to exceed 12-amps per power unit.
- Do not plug the power cord into an extension cord.
- Inspect power cord before each use. Do not use power cord that is damaged.
- Do not unplug by pulling on the cord.
- Do not step on, drive over, drag, or place objects on the power cord.
- For indoor use only. Do not install or store the unit where it will be exposed to moisture. Keep dry.
- For added safety, plug the timer into a grounded three-prong receptacle controlled by a GFI (Ground Fault Interrupter) circuit breaker.

Note: Cart includes four QuickBrick™ removable trays with a Velcro® retaining straps for charge adapters to provide fast and easy wiring for quick deployment.

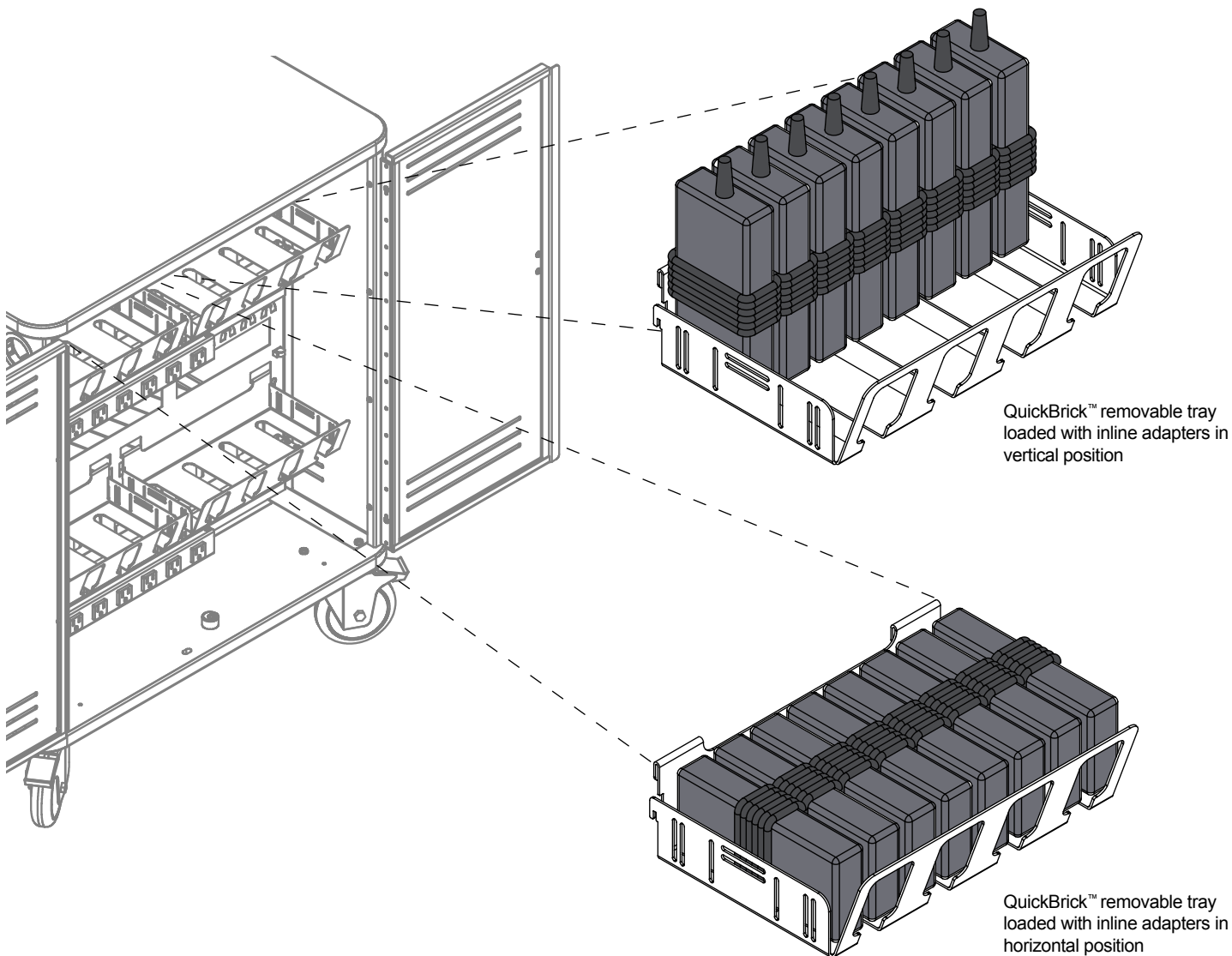

Options



Hook-and-loop Strap Kit - 95004

(16) .75" [1.91 cm] x 12" [30.48 cm],
and (32) .75" [1.91 cm] x 5" [12.7 cm]

Warranty

WE WILL MAKE IT RIGHT FOR YOU!

Spectrum is committed to provide complete customer satisfaction. Each of our products is manufactured from the best materials available and each product is stringently monitored throughout the production process through our P.A.C.E. program (Product Assurance to meet Customer Expectations).

We expressly warrant that Spectrum products will be of good quality and workmanship and free from defect for the period set out in the warranty table below from the date of delivery. This warranty shall not apply to defects or damage resulting from misuse, abuse, neglect, improper care, modification or repair not authorized by Spectrum, or any other cause outside the control of Spectrum. Spectrum will, at its sole option, either repair or replace the defective product.

This warranty is exclusive; no other warranty, written or oral, is expressed or implied. This warranty is given by Spectrum to Buyer and to no other person or legal entity. No Spectrum dealer, distributor, agent or employee is authorized to make any modification or addition to this warranty.

NOTWITHSTANDING ANYTHING TO THE CONTRARY, SPECTRUM WILL NOT UNDER ANY CIRCUMSTANCES BE LIABLE FOR INDIRECT OR LIQUIDATED DAMAGES, INCLUDING CONSEQUENTIAL, INCIDENTAL AND SPECIAL DAMAGES. IN NO EVENT SHALL SPECTRUM'S LIABILITY, WHETHER UNDER CONTRACT OR WARRANTY, IN TORT OR OTHERWISE, EXCEED THE PURCHASE PRICE RECEIVED BY SPECTRUM FOR THE PRODUCT AT ISSUE AND "RECALL ACTION" EXPENSES. SPECTRUM SHALL NOT BE SUBJECT TO ANY OTHER OBLIGATIONS OR LIABILITIES, WHETHER ARISING OUT OF BREACH OF CONTRACT, WARRANTY, TORT (INCLUDING NEGLIGENCE AND STRICT LIABILITY) OR OTHER THEORIES OF LAW, WITH RESPECT TO PRODUCTS SOLD OR SERVICES RENDERED BY SPECTRUM, OR ANY UNDERTAKINGS, ACTS OR OMISSIONS RELATING THERETO.

Our Customer Service Department is ready to provide immediate attention to any questions, comments or concerns. They are available to answer your calls Monday through Friday from 7 am to 5 pm CST. In addition your product comments or concerns are welcome via e-mail at: spectrum@spectrumfurniture.com.

Warranty Table

effective 1/1/2015

Item	Warranty Period
Adjustable Crank / Electric Desk Legs	• 1 Year
Flat Panel Desk Gas Cylinders	
Chairs <ul style="list-style-type: none"> • Adjustable Height Chair Parts – including frames, gas cylinders, wood and plastic parts, control handles, casters • Adjustable Height Chair Upholstery • In-Stock Upholstery • Graded-In Fabrics and Customer Owned Material 	<ul style="list-style-type: none"> • 7 Years • 2 Years • 2 Years • No Warranty
Height Adjustable Columns and Lifts	• 1 Year
General Use Casters	
Electrical (including timers and LINAK actuators)	• 2 Years
Keyboard / Mouse Trays	• 1 Year
Flat Panel Monitor Arms <ul style="list-style-type: none"> • Flat Panel Monitor Arm – General Parts • Flat Panel Monitor Arm – Gas Cylinders 	<ul style="list-style-type: none"> • 5 Years • 2 Years
Desks and Lecterns <ul style="list-style-type: none"> • Computer Desk Chassis • Cart Chassis • Lectern Chassis 	• 10 Years

