

Assembly Instructions

⚠ Important ⚠

Before you begin, read and comply with all safety and operating instructions, and ensure all parts and correct quantities are included.

Any parts damaged during shipment must be reported within 5 days of receipt. To report information regarding missing parts or damage, to purchase parts or accessories, or if you have any questions, please contact us.

www.spectrumfurniture.com
800-235-1262, 715-723-6750

Thank you for purchasing Spectrum products!

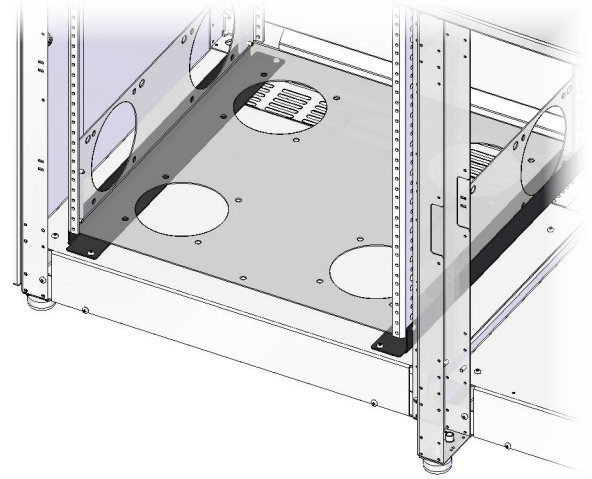

Bracket Kit for 55197 Rack Cube (for AV Credenza 55532)

55534

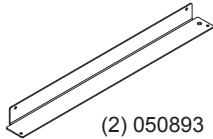

(2) 050893
Rack cube support
bracket

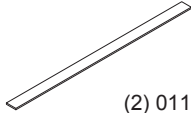

(2) 0115173
1"W x 18.5"L Polyethylene
slide with (S1101) 3/4"
double-sided tape



(4) 0119245
Spacer

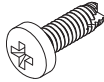

(4) 0100167
8-32 x 1/2" PH
thread-cutting screw

Note: Do not tighten fasteners completely until all have been installed. Keeping them loose will help with alignment during assembly.



1. Apply slides to brackets

1. Apply a polyethylene slide to each bracket as shown. (2 total). **Figure 1.**

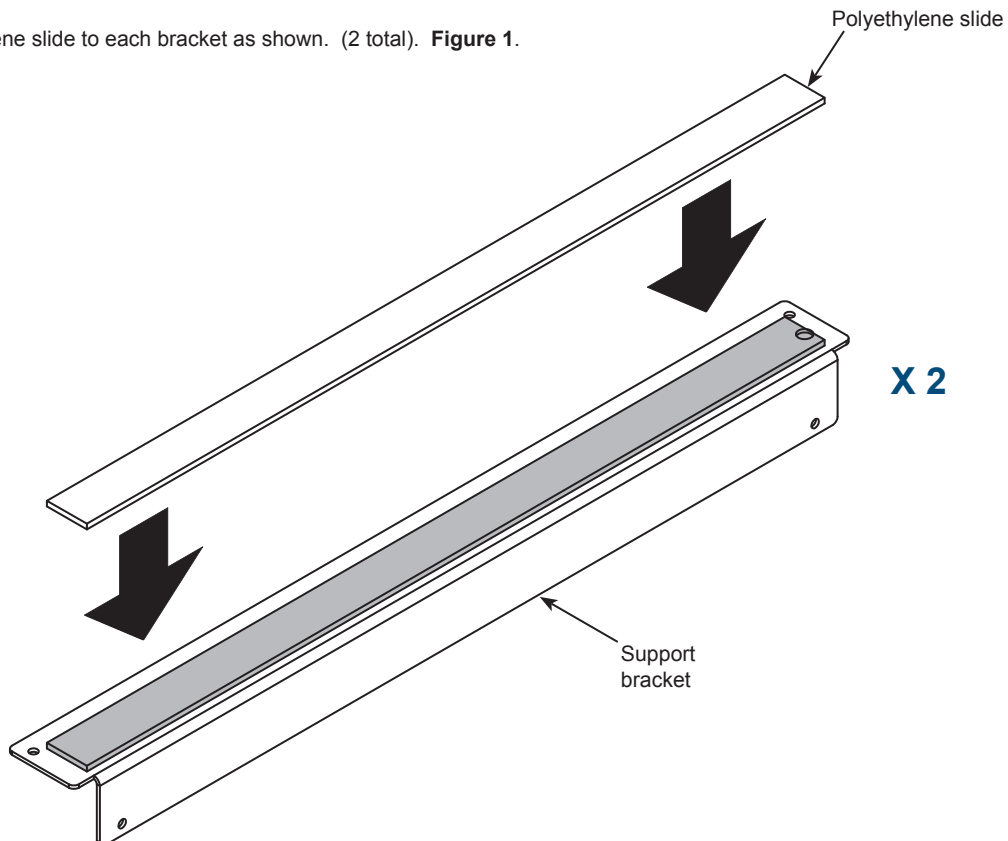

Figure 1

2. Attach brackets to cube

1. Remove the bottom 8-32 screw from each rack rail on the assembled cube. (4 total). **Figure 2.**
2. Align the bottom rack rail holes with the support bracket holes and attach with the previously removed 8-32 screws as shown.

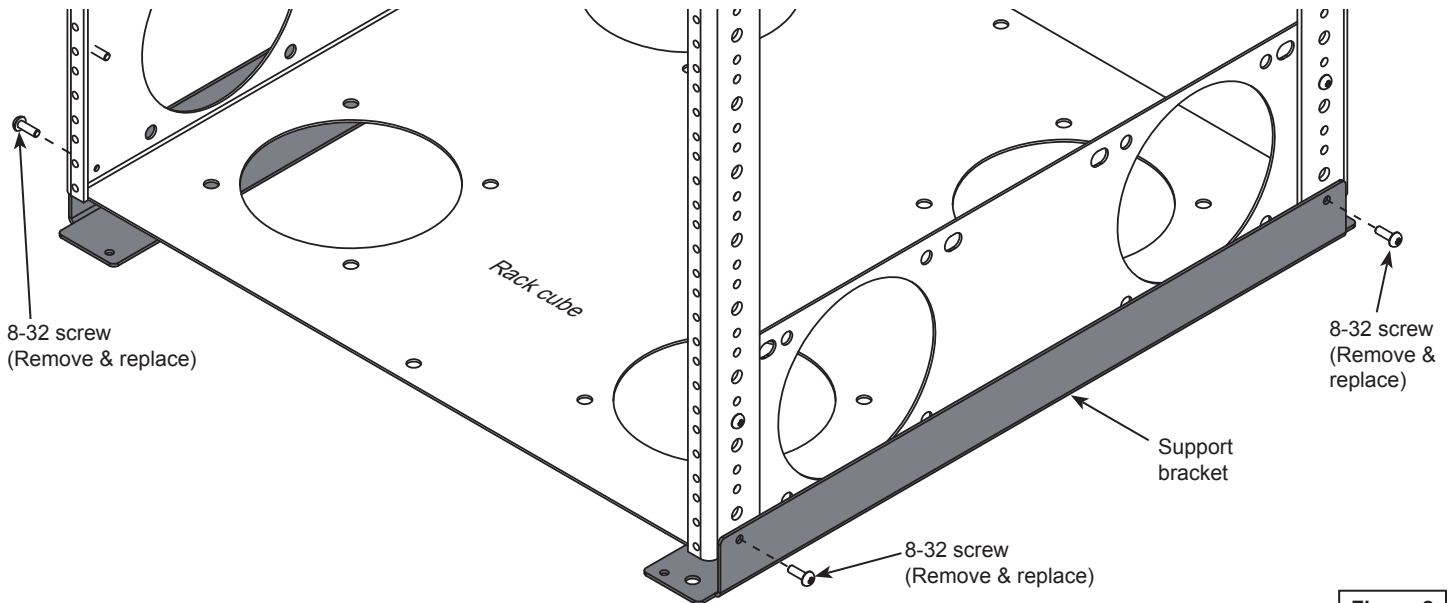

Figure 2

3. Install assembled cube

1. Open the doors and set the rack cube assembly into the credenza. Align the support brackets with the base mounting holes. **Figure 3.**
2. Place a spacer between the support brackets and base at each mounting hole (4 total). **Figure 3A.**
3. Attach the rack assembly to the base with (4) 8-32 x 1/2" PH thread-cutting screws.

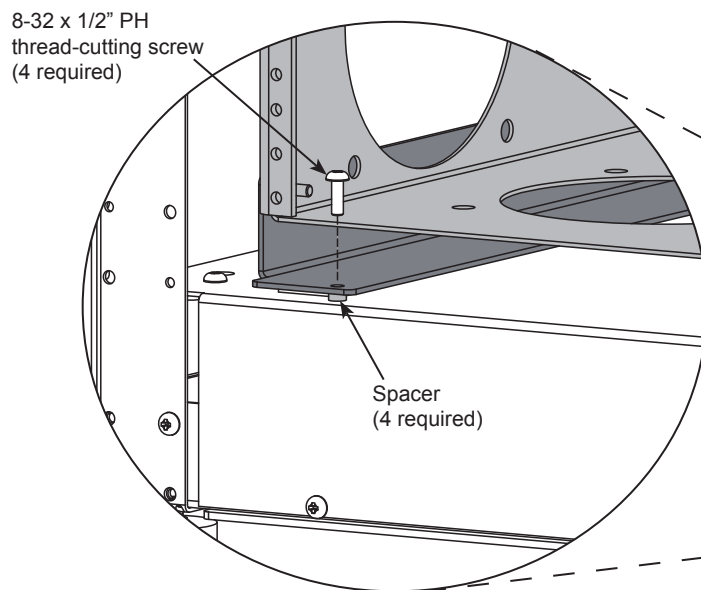

Figure 3A

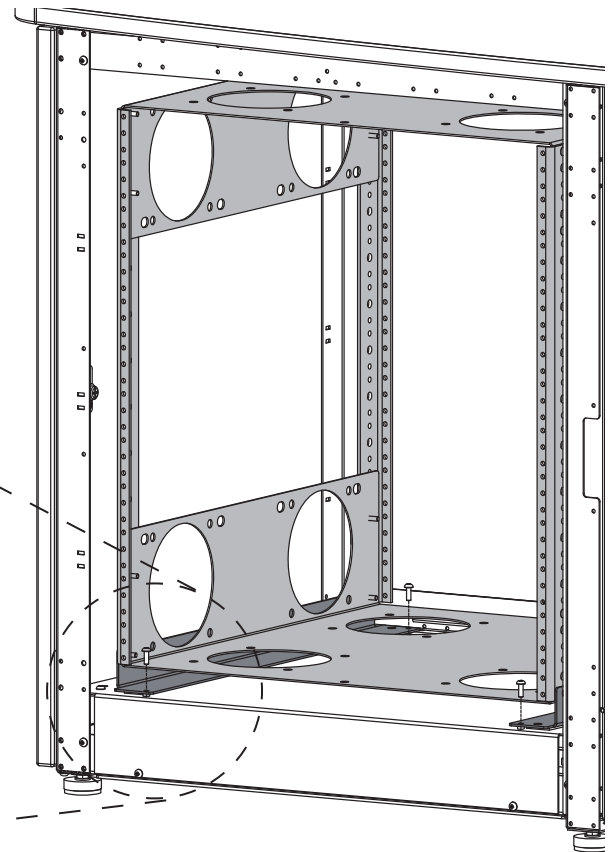

Figure 3