

Assembly Instructions

⚠ Important ⚠

Before you begin, read and comply with all safety and operating instructions, and ensure all parts and correct quantities are included.

Any parts damaged during shipment must be reported within 5 days of receipt. To report information regarding missing parts or damage, to purchase parts or accessories, or if you have any questions, please contact us.









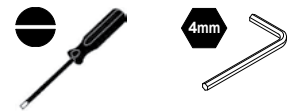

www.spectrumfurniture.com
800-235-1262, 715-723-6750

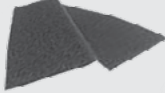
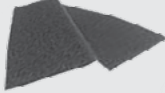
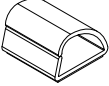
Thank you for purchasing Spectrum products!



LED Lighting Kit for Shoutcaster 37386



PART#	QTY	ITEM
021538	8	#8 x 1/2" PHTS 
0175951	2	Bracket 
0110254	2	2" x 3" Hook 
0110255	2	2" x 3" Loop 
0192395	2	3/4" x 3/4" Cable holder 
058423	6	5-1/2" Cable tie 
0192178	1	6" Driver adapter 
0192179	1	12 volt power supply 
0192180	1	12" RGB F to M cable link 
0192181	1	Plus shape connector 
0192182	1	LED Controller and RF Remote 
0192183	2	72" Interconnection cable 
0192184	2	12" RGB LED Tape light 

1 Remove covers from LED controller

- Using a micro flat head screwdriver, remove the two plastic covers from the controller.



2 Connect driver adapter wires

1. With the power unplugged, place the driver adapter power wires into the selected slots.
2. Tighten securely.

3 Connect RGB wires to controller

1. Place the RGB wires from the 12" RGB F to M cable link into the selected slots.
2. Tighten securely.



4 Connect and test LED's

1. Connect the LED components as shown and make sure both tape strips light up.

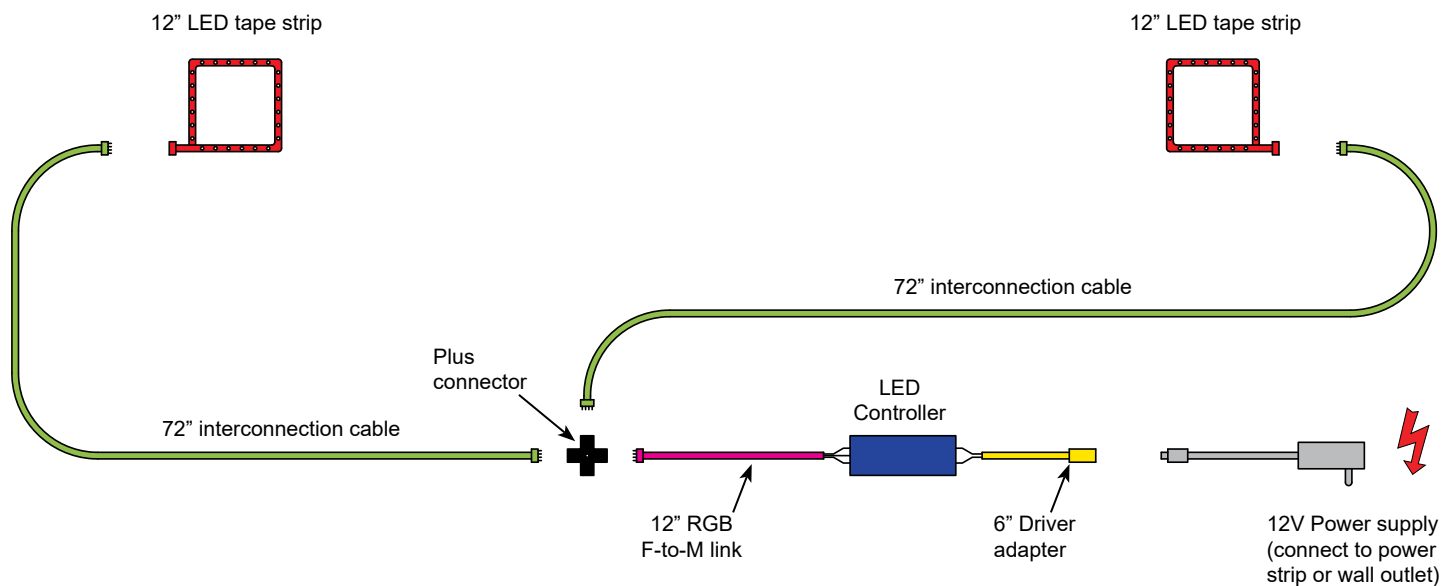

Assembly tip: If the LED tape lights do not light up, check polarity of connectors. They may need to be disconnected, rotated 180-degrees and reconnected.

5 Remove accent / side panels (if installed)

1. Remove the accent / side panels by removing the 4mm JC bolts inside unit.

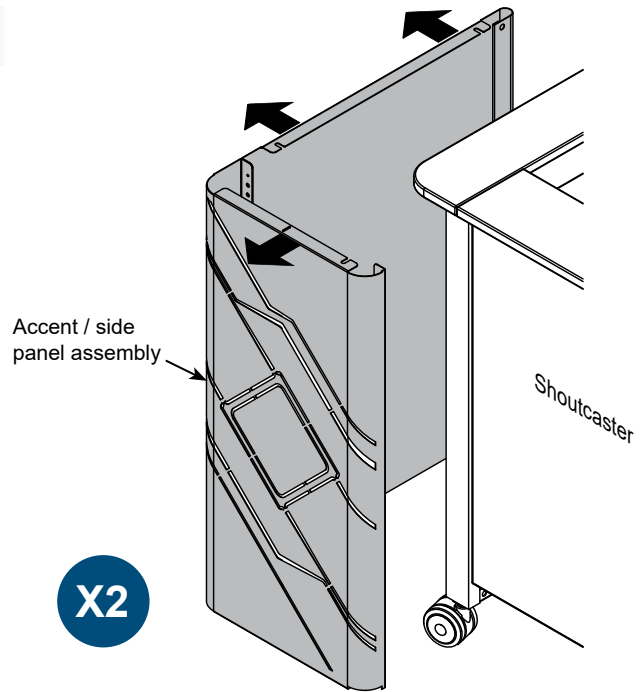

6 Remove brace securing styrene backer

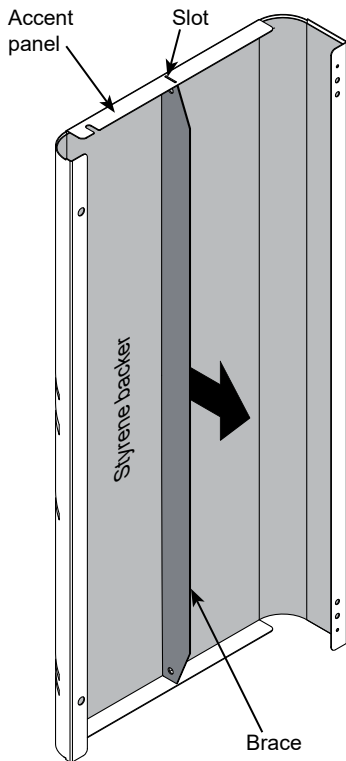

X2

7 Secure backer panel with screws

1. Position backer panel tight to worksurface.
2. Install (4) #8 x 1/2" PHTS screws at the locations shown to secure the backer.
3. Repeat on other backer panel.

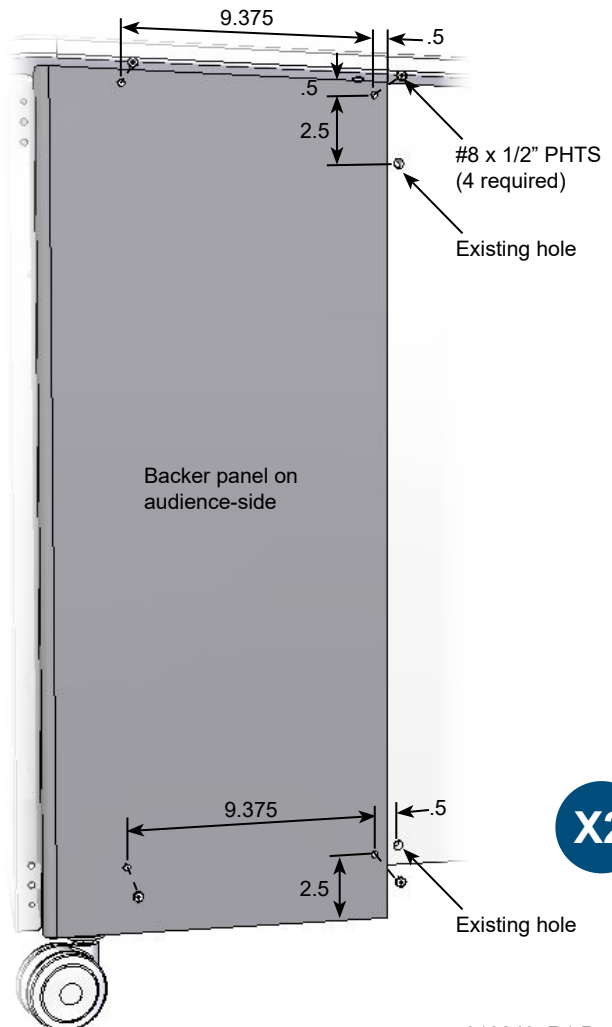

8 Attach bracket inside accent panel

1. Center and attach the the bracket behind the accent panel using hook and loop.
2. Repeat on other panel.

X2

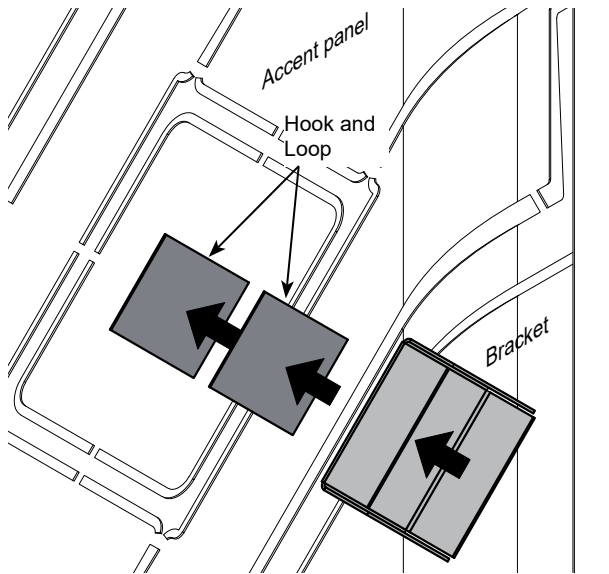

9. Apply LED tape strip to bracket

1. Apply the 12" LED tape strip around all four sides of the bracket with LED bulbs pointing out.
2. Apply the cable holder as shown to accent panel.
3. Repeat on other panel.

X2

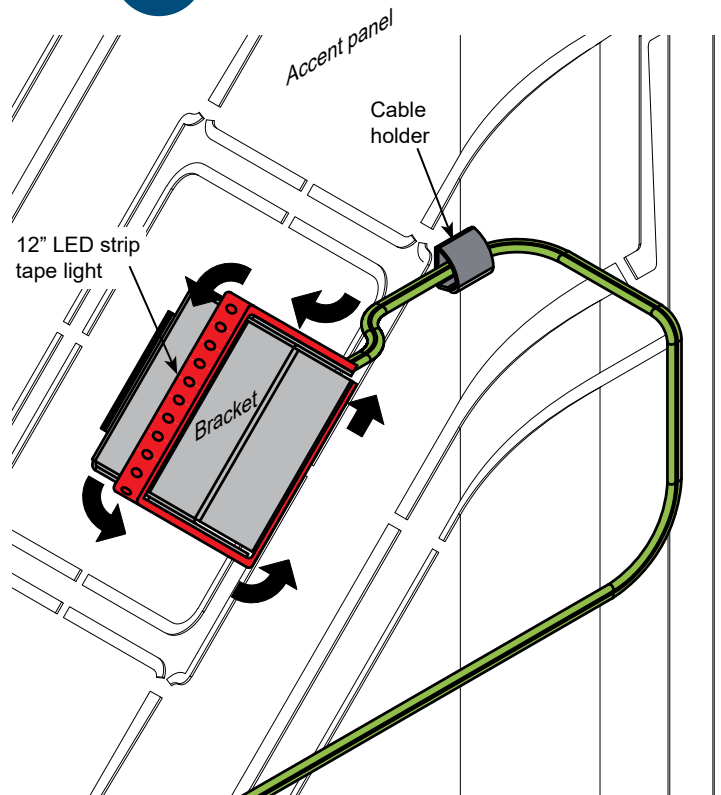

10. Replace accent / side panels

Align and “hook” the 3 panel mounting slots over the installed screws from step 11 to get each panel assembly into position.

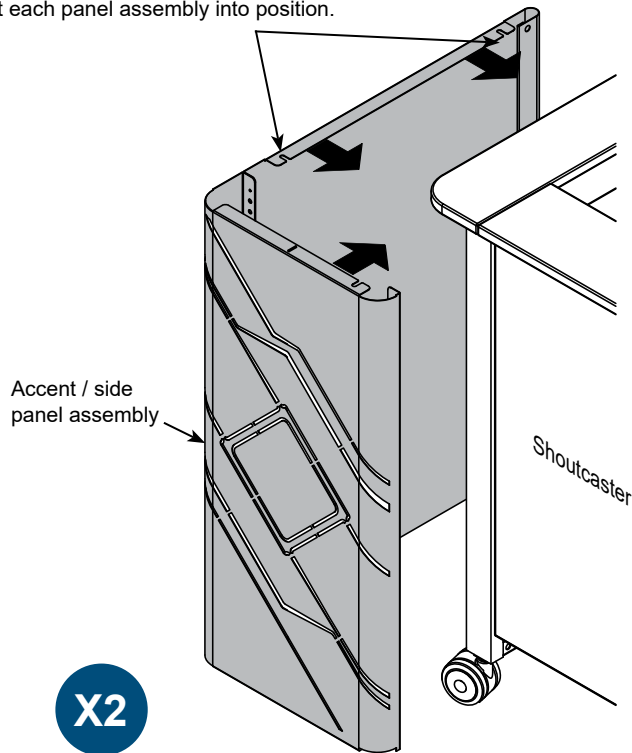

11. Secure accent / side panel

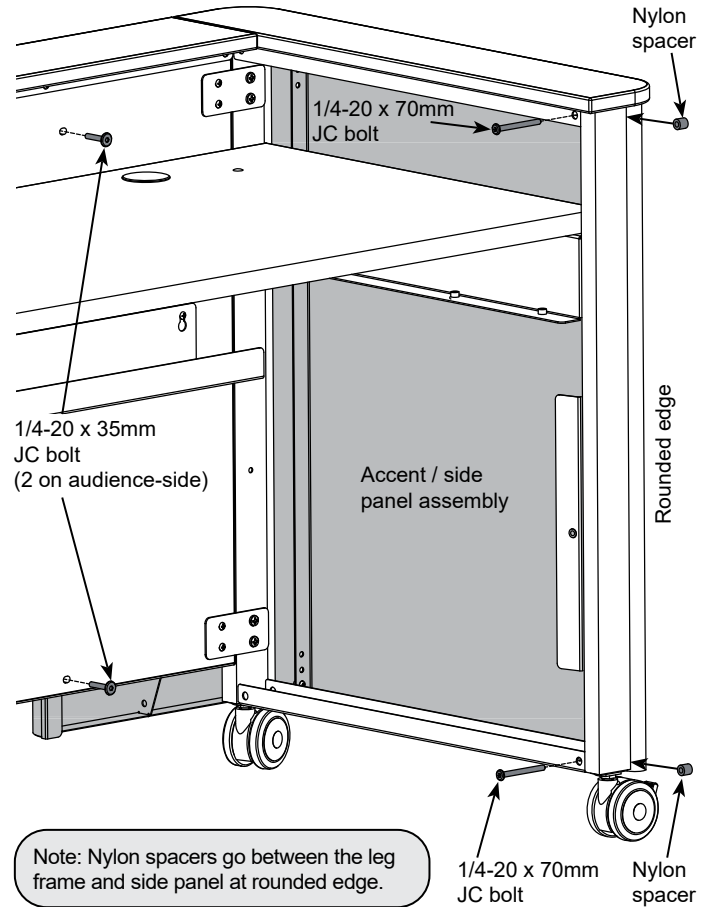

12. Route wires

1. Place the plus connection, LED controller, and 12V power supply in the cord channel.
2. Route each 72" interconnection cable around to the backer panel and plug into the LED tape. (Use one cable holder on each side to support and route the wire).

