

# Assembly Instructions

## ⚠ Important ⚠

Before you begin, read and comply with all safety and operating instructions, and ensure all parts and correct quantities are included.

Any parts damaged during shipment must be reported within 5 days of receipt. To report information regarding missing parts or damage, to purchase parts or accessories, or if you have any questions, please contact us.

[www.spectrumfurniture.com](http://www.spectrumfurniture.com)  
800-235-1262, 715-723-6750

Thank you for purchasing Spectrum products!

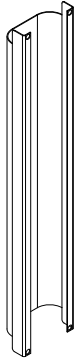

(2) 0131647  
Cord Chase

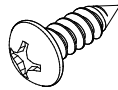

(4) 021491  
#8 x 1/2" PHSM screw  
(for T-Leg installations)

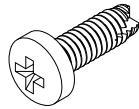

(4) 0100167  
8-32 x 1/2" PH Thread cutting screw  
(For eLift Leg installations)

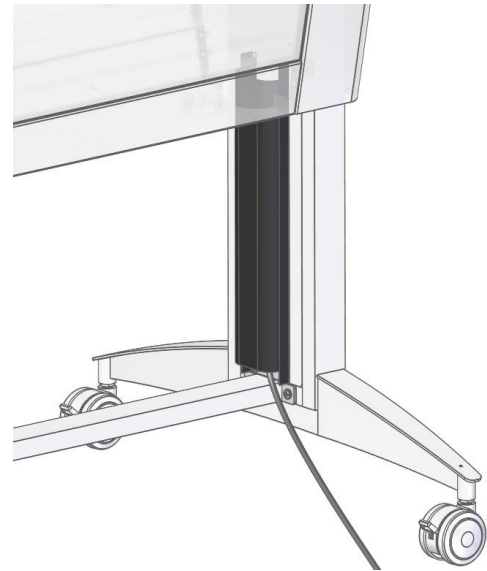

## Cord Chase for Optio Table 38999



## Installation on tables with T-Legs

Note: Laminate insert panels are required for installation on tables with T-legs.

1. If installing on a table with an AV technology channel, remove one of the side panels for easier access.
2. Remove the (2) existing lower screws securing the T-leg laminate panel. The same two mounting holes will be used for the chase.
3. Orient the cord chase as shown in **Figure 1**.
4. Align the mounting holes and attach with (4) #8 x 1/2" PHSM screws.
5. Repeat procedure on second cord chase.
6. Route cords and wires from the worksurface / AV channel, through the cord chase to the floor.

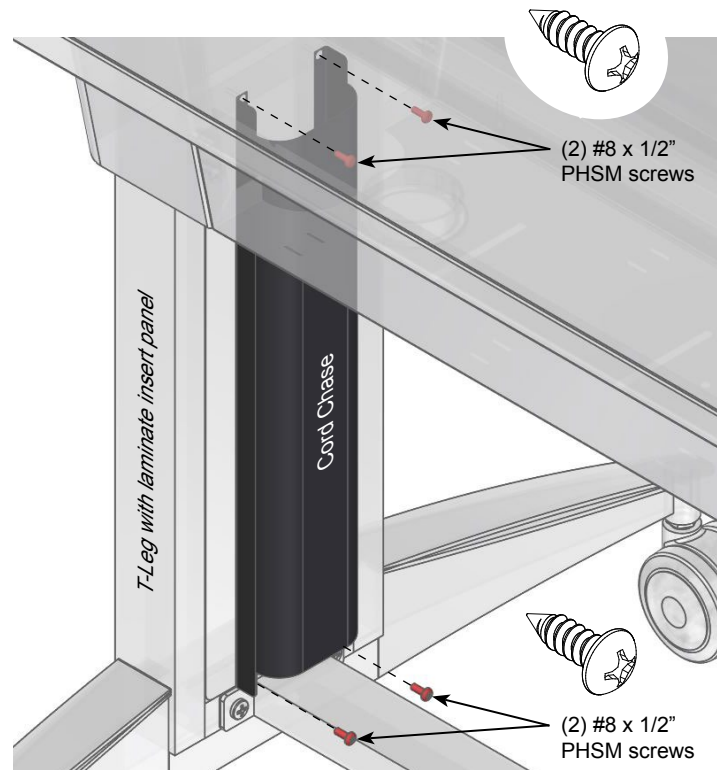

## Installation on tables with eLift Legs

1. If installing on a table with an AV technology channel, remove one of the side panels for easier access.
2. Orient the cord chase as shown in **Figure 2**.
3. Align the mounting holes and attach with (4) 8-32 x 1/2" PH thread-cutting screws.
4. Repeat procedure on second cord chase.
5. Route cords and wires from the worksurface / AV channel, through the cord chase to the floor. Be sure there is plenty of slack in the cords provided for raising / lowering the eLift legs.

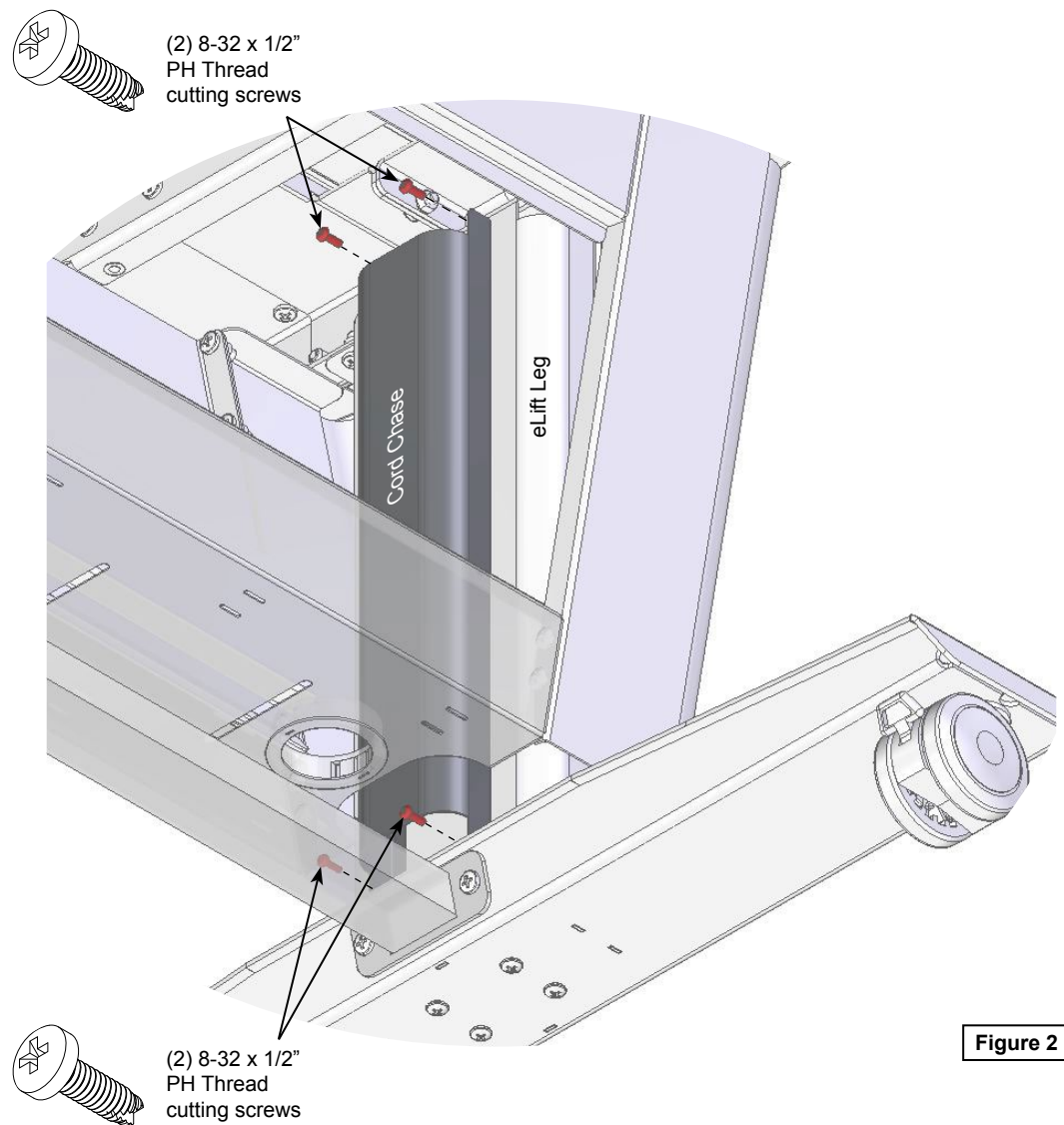

Figure 2