

Assembly Instructions

⚠ Important ⚠

Before you begin, read and comply with all safety and operating instructions, and ensure all parts and correct quantities are included.

Any parts damaged during shipment must be reported within 5 days of receipt. To report information regarding missing parts or damage, to purchase parts or accessories, or if you have any questions, please contact us.

www.spectrumfurniture.com
800-235-1262, 715-723-6750

Thank you for purchasing Spectrum products!



(4) 052605
1/4-20 x 15mm JC bolt



(1) 025039
Hex wrench

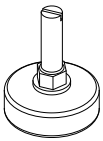

(2) 025068
1/4-20 x 15mm Glide

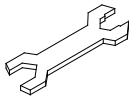

(1) 025069
Glide wrench

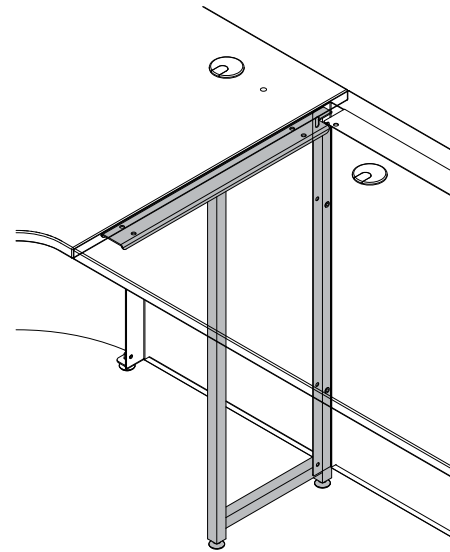

Mid-Support Leg for IMC
68104 - 29"H
68154 - 36"H

1. Install glides

1. Install the (2) glides onto the mid-support leg. **Figure 1.**
(The glides can be rotated to level the unit later.)

Tools
Required

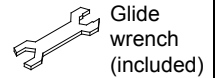
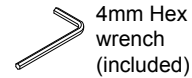

2. Install Mid-Support Leg

1. Align the mid-support leg and wall filler panel mounting holes as shown. **Figure 1.**
2. Attach the mid-support leg to the wall filler panels with (4) 1/4-20 x 15mm JC bolts. (Note: These bolts come with the wall filler panels).
3. Set both worksurfaces onto the console with the seam centered over the mid-support leg.
4. Attach to worksurfaces with (4) 1/4-20 x 15mm JC bolts.

Note: Mid-support legs are used to connect and support the seam of two worksurfaces.

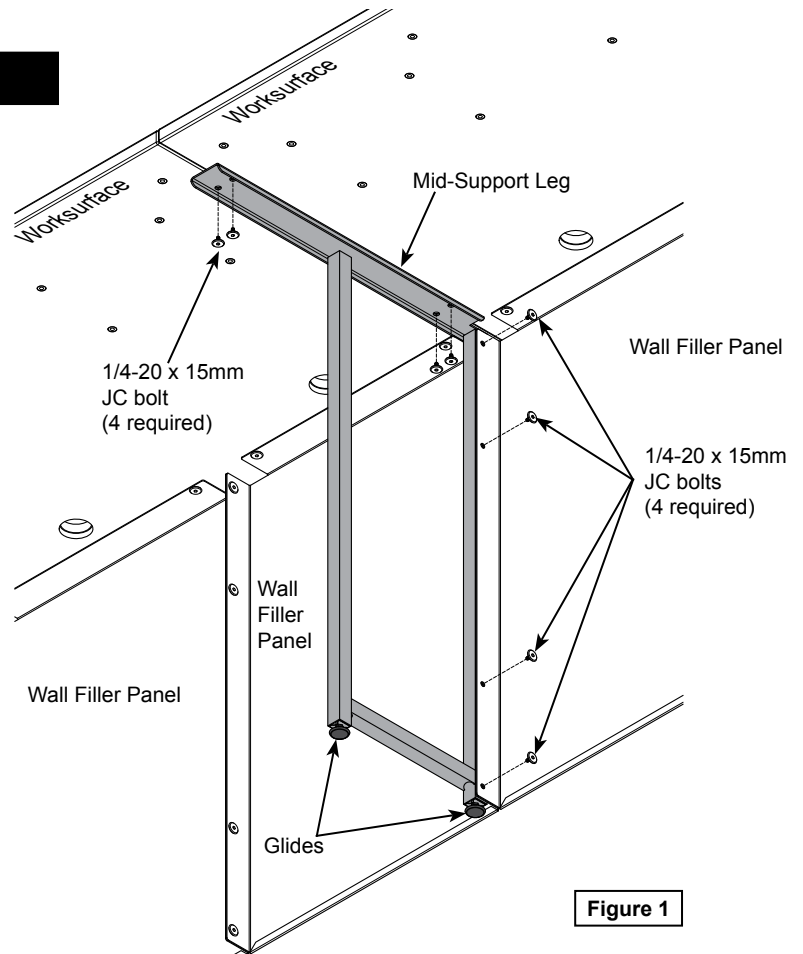

Figure 1