

Assembly Instructions

⚠ Important ⚠

Before you begin, read and comply with all safety and operating instructions, and ensure all parts and correct quantities are included.

Any parts damaged during shipment must be reported within 5 days of receipt. To report information regarding missing parts or damage, to purchase parts or accessories, or if you have any questions, please contact us.

www.spectrumfurniture.com
800-235-1262, 715-723-6750

Thank you for purchasing Spectrum products!

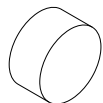

(2) 044573
5/8" Adhesive
bumpers

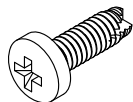

(4) 0100167
8-32 x 1/2" PH
Thread ctg screw

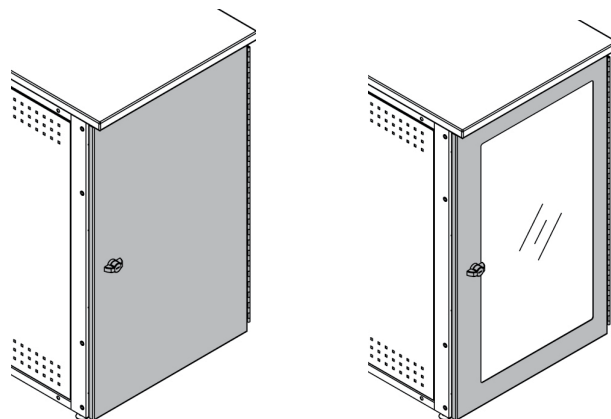

1. Attach door to equipment rack

1. The locking door is symmetrical and can be mounted to swing from the left or right-side of the equipment rack. Before you begin, determine which side the door will be attached.
2. With the hinge open, align the mounting holes as shown and attach to equipment rack frame with (4) 8-32 x 1/2" PH thread cutting screws. Be sure the screws are installed straight. Do not tighten completely until all screws are installed. **Figure 1.**

2. Install bumpers

1. With the door open, install the (2) adhesive bumpers onto the equipment rack frame as shown. **Figure 2.**

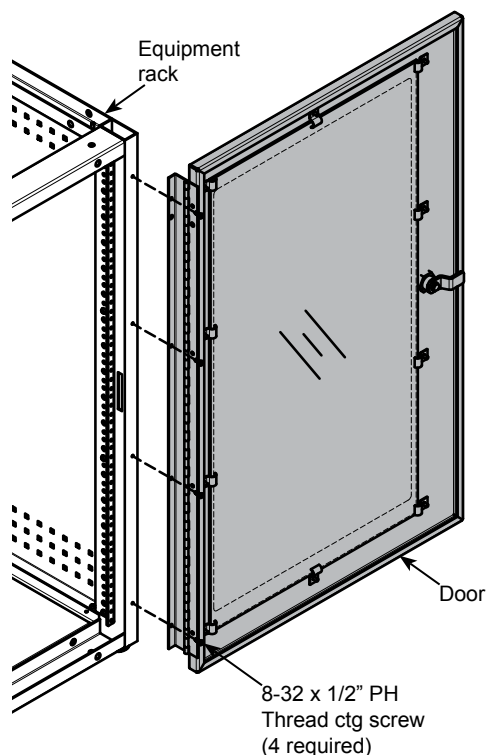
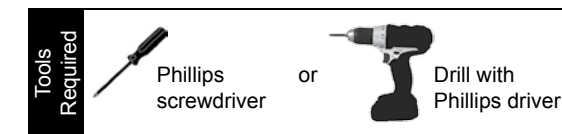

Figure 1



Note: If using an electric drill with Phillips driver to install, be sure to use a low torque setting to prevent stripping out the screw holes.

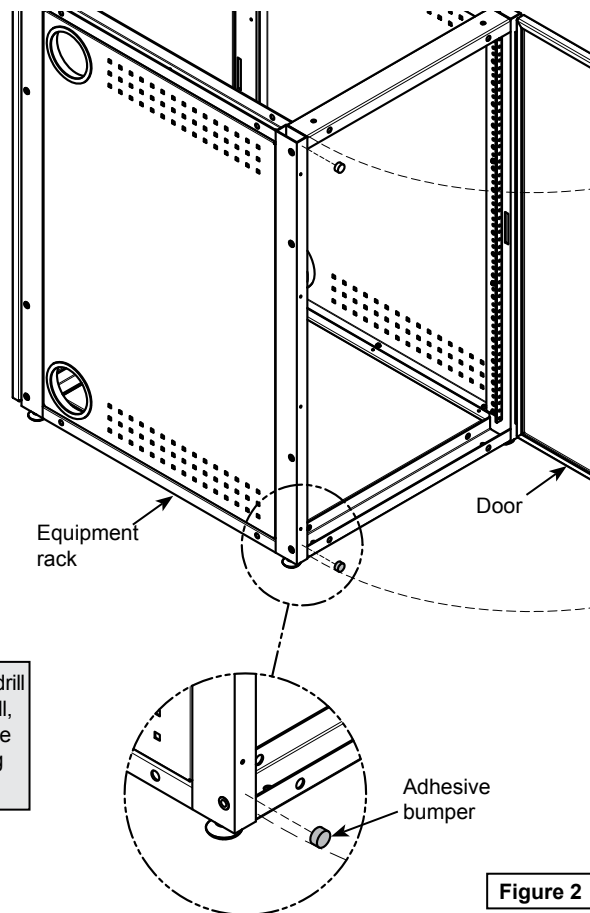

Figure 2