

# Assembly Instructions

## ⚠ Important ⚠

Before you begin, read and comply with all safety and operating instructions, and ensure all parts and correct quantities are included.

Any parts damaged during shipment must be reported within 5 days of receipt. To report information regarding missing parts or damage, to purchase parts or accessories, or if you have any questions, please contact us.

[www.spectrumfurniture.com](http://www.spectrumfurniture.com)  
800-235-1262, 715-723-6750

Thank you for purchasing Spectrum products!

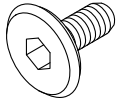

(4) 052605  
1/4-20 x 15mm JC bolt

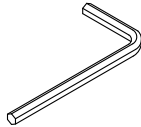

(1) 025039  
4mm Hex wrench

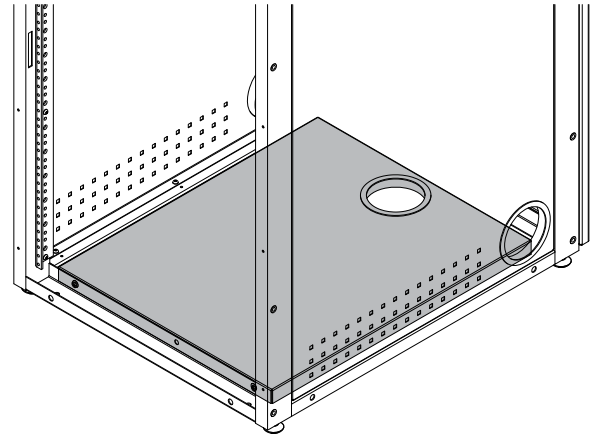

## Bottom Shelf for IMC equipment rack 68203

### Shelf installation

1. The shelf grommet hole allows wires to be run into the equipment rack from below. Before mounting, determine if the grommet hole should be at the front or rear of the equipment rack.
2. Align the shelf with the (2) front mounting holes at the bottom of the equipment rack as shown.
3. Attach with (2) 1/4-20 x 15mm JC bolts.
4. Open the rear door and repeat this procedure on the rear of the equipment rack-installing (2) additional 1/4-20 x 15mm JC bolts.
5. Tighten all bolts securely.

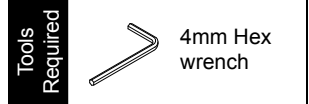

#### Grommet at rear

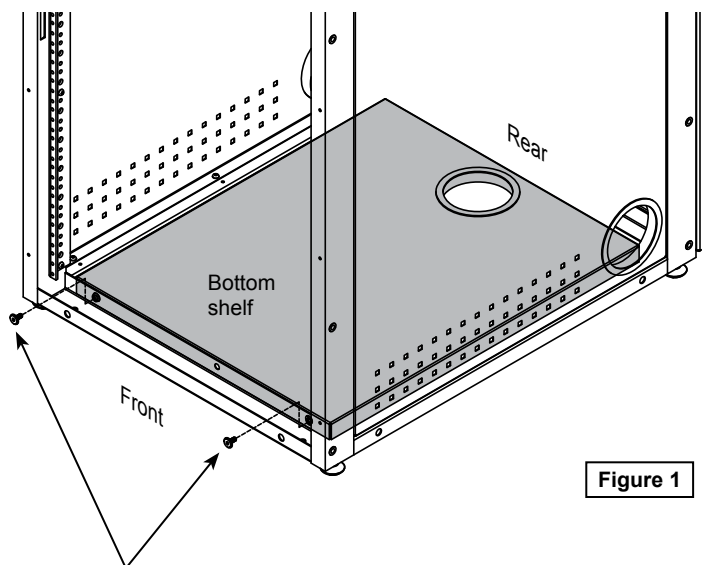

Figure 1

1/4-20 x 15mm JC bolt  
(2 on front, 2 on rear)

#### Grommet at front

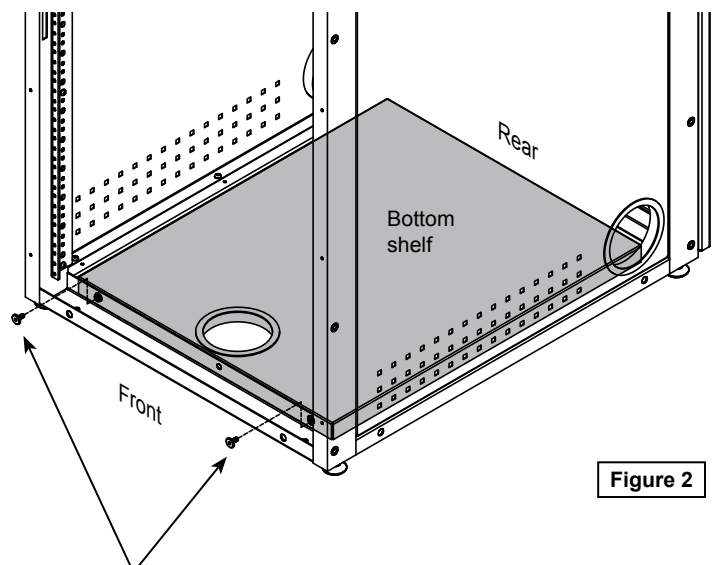

Figure 2

1/4-20 x 15mm JC bolt  
(2 on front, 2 on rear)