

Technical Specifications

37239

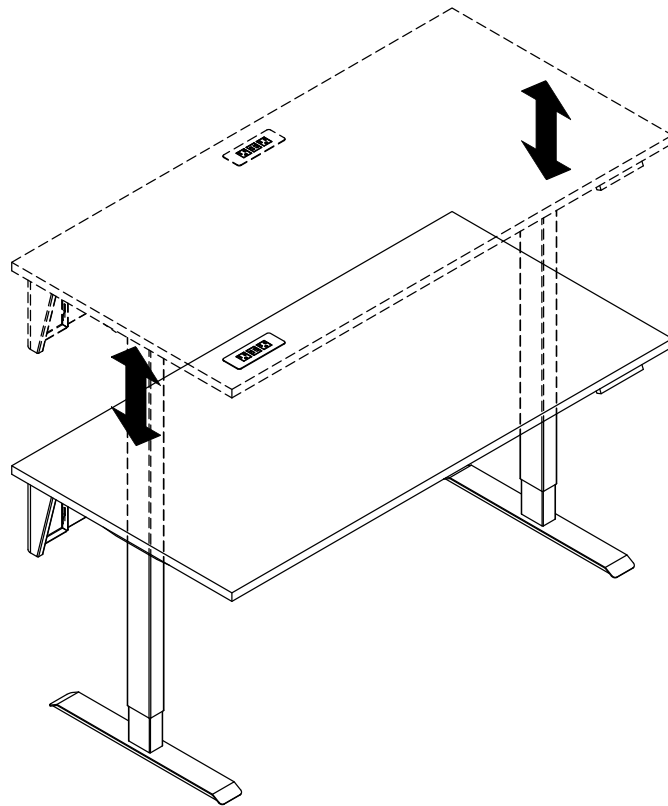

(60"W shown with optional power module, and modesty panel)



Use the Flex Active Electric Sit-to-Stand Table where worksurface height adjustment or ADA compliance is required. Designed as a companion to Spectrum's Flex Active line of tables, this adjustable height table features electric actuators that provide 19.75" of worksurface height adjustment with a lift capacity of 440 lb. The table includes glides for stationary use or casters for easy mobility. Available accessories: modesty panel, CPU sling, and worksurface power module.

Features and Benefits

- Electric telescoping legs provide 19.75" of worksurface height adjustment
- Available in 72", 60", and 48" wide versions
- Available in 30" or 24" depths
(24" depth is ideal for laptop use or when space is limited)
- Scratch and impact-resistant high-pressure laminate worksurface
- Worksurface brace provides support and minimizes flexing
- Durable powder coated (black) steel legs provides a long-lasting finish
- Choice of stationary glides or 3" locking casters (both included)
- Matching vinyl edge trim on worksurface edges protect walls and furniture
- Optional worksurface Power Module with AC power plug (requires worksurface cutout)
- Optional CPU sling provides mounting for CPU tower
- Standard laminate colors available to match existing furniture
- Ships KD (knocked down) and requires assembly
- Meets or exceeds applicable ANSI-BIFMA test standards
- Warranted to be free of all defects in materials and workmanship for 10 years
- Designed and assembled in Chippewa Falls, WI, USA

Ordering Instructions

Spectrum has designed this product to receive the useful options shown here. To ensure your options are ordered correctly please call 1-800-235-1262.

Color Options

- Worksurface and optional modesty panel laminate available in Spectrum Expressions colors.
- Electric legs are available in black powder-coated metal only.
- See spectrumfurniture.com for complete color information.

Construction

- The worksurface is constructed from 1" thick composite board with .030" [.762mm] high-pressure laminate on one face, and a balancing phenolic backer on the opposing face
- Worksurface edges are covered with vinyl edgeband
- The formed worksurface brace is 14-gauge steel
- All metal components are finished with a scratch-resistant powder coat epoxy
- All tables are shipped knocked-down (KD) and require assembly

Specifications

Sizes available	48"W [121.92 cm] x 24"D [61 cm] 60"W [152.4 cm] x 24"D [61 cm] 72"W [182.9 cm] x 24"D [61 cm]	48"W [121.92 cm] x 30"D [76.2 cm] 60"W [152.4 cm] x 30"D [76.2 cm] 72"W [182.9 cm] x 30"D [76.2 cm]
Worksurface height adjustability (floor to top of worksurface)	<u>Casters:</u> 53.25"H [135.3 cm] (fully-raised) 33.5"H [85 cm] (fully-lowered)	<u>Glides:</u> 50.25"H [127.6 cm] (fully-raised) 30.5"H [77.5 cm] (fully-lowered)
ADA-compliance*	 1 ADA seat per table <i>*Minimum ADA guidelines for knee clearances are 30"W x 19"D x 27"H</i>	
Electrical	<ul style="list-style-type: none"> • Range of motion: 19.75" [50.2 cm] • ~26 seconds from fully-lowered to fully-raised • Digital height display • 4 memory presets with keypad lock • Soft start / stop • 110 VAC 	<ul style="list-style-type: none"> • Anti-collision protection • Max load: 979N (220 lb) [100 kg] per actuator • Total lift capacity: 440 lb [200 kg] • Actuators tested for 40,000 cycles • Approved by: CE, UL, CUL, SAA • Electric legs are black powder-coated metal
Casters	<ul style="list-style-type: none"> • Total height: 3" [7.6 cm] • Wheel diameter: 2.36" [60 mm] • Locking: all 4 casters 	
Certifications / Compliance	<ul style="list-style-type: none"> • SCS Indoor Advantage Certified (pending) 	<ul style="list-style-type: none"> • Meets or exceeds applicable ANSI-BIFMA test standards
Shipping weight (nominal)	101 lb [45.9 kg] - 48"W x 24"D 113 lb [51.3 kg] - 60"W x 24"D 122 lb [55.4 kg] - 72"W x 24"D	113 lb [51.3 kg] - 48"W x 30"D 125 lb [56.8 kg] - 60"W x 30"D 138 lb [62.7 kg] - 72"W x 30"D

Specifications subject to change without notice

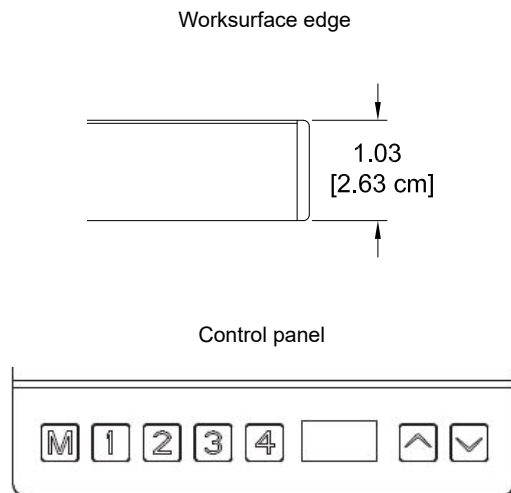

4 Glides and 4 Casters included

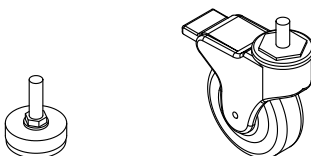

Available with 1-3/8" thick hardwood (HW) beech worksurface (58"W x 26.75"D only)

Note: Modesty panel and power module options not compatible with HW worksurface. Hardwood worksurface not SCS certified

Worksurface size options

ORDER CODE A = 48"W x 24"D

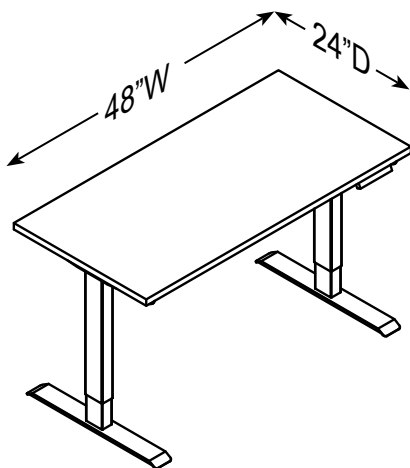

ORDER CODE B = 48"W x 30"D

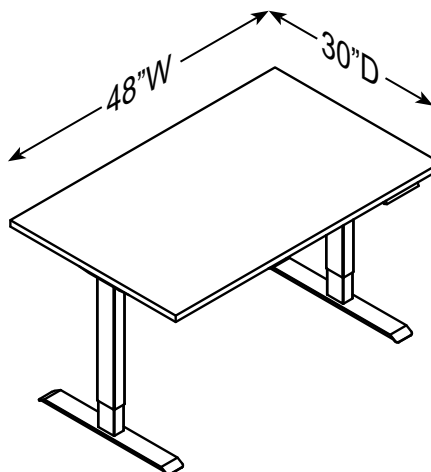

Note: 48"W tables are not wide enough for two people in most situations. Spectrum recommends at least a 60"W table to accommodate 2 people.

ORDER CODE C = 60"W x 24"D

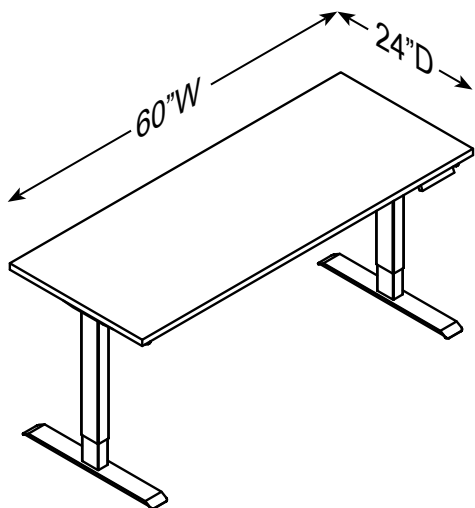

ORDER CODE D = 60"W x 30"D

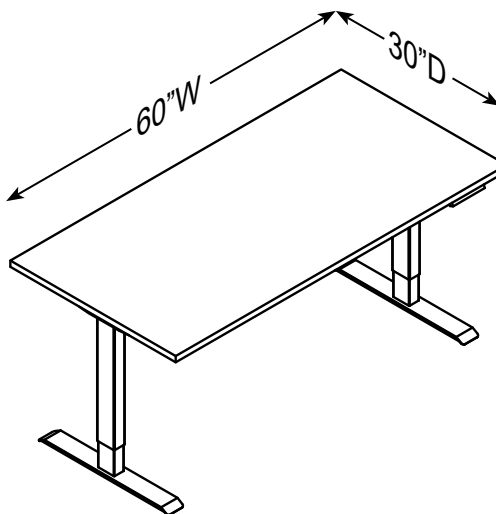

ORDER CODE E = 72"W x 24"D

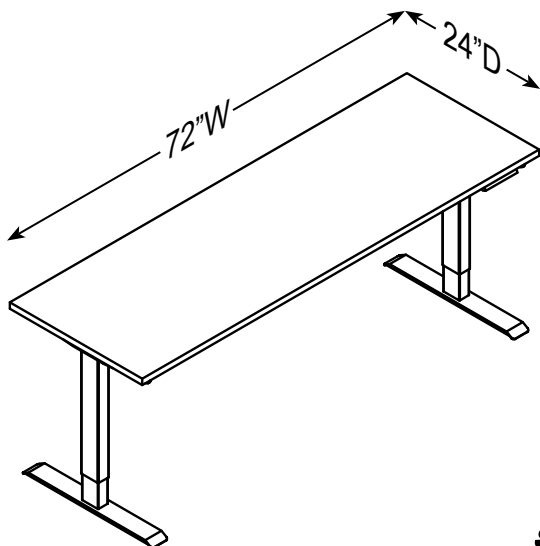

ORDER CODE F = 72"W x 30"D

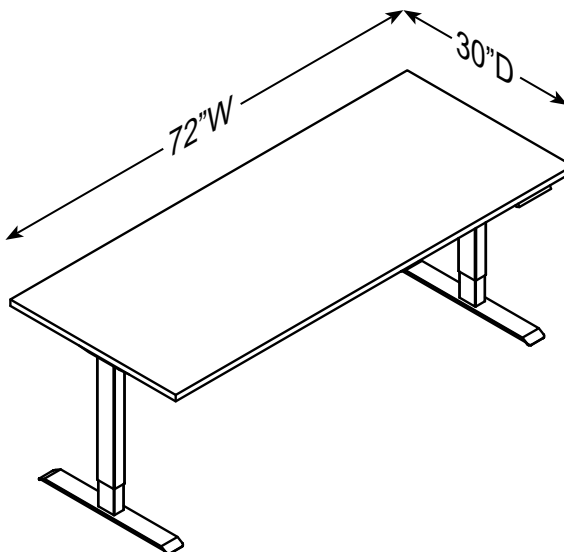

Power module

ORDER CODE 0	None
---------------------	------

ORDER CODE 4	Black Power Module
ORDER CODE 3	Silver Power Module
ORDER CODE 8	White Power Module

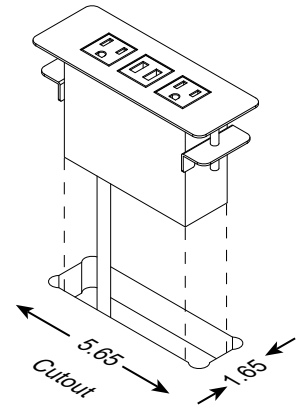
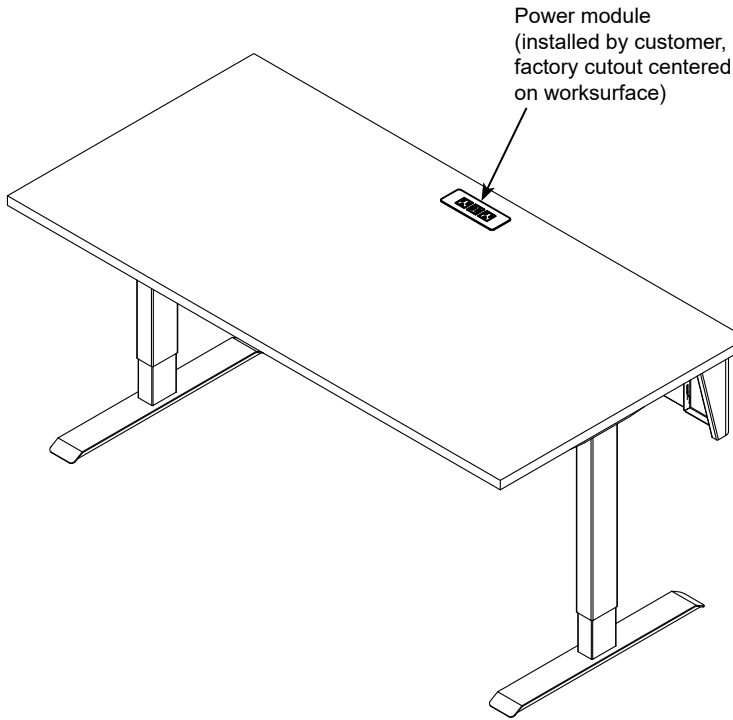

Worksurface cutout
(provided when configured)

- Customer-installed
- (2) AC receptacles (tamper-resistant)
- (2) USB ports rated at 2.1A each (10.5 watts)
- Aluminum housing and flange
- 9' 14AWG *3C power cord
- When specified, the Power Module is centered on the audience-side edge of the worksurface
- Worksurface cutout size: 5.65"W x 1.65"D
- ETL-certified

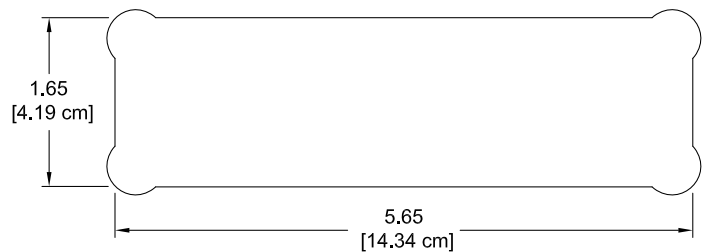

Black



Silver



White



Modesty panel

ORDER CODE 0	None
---------------------	------

ORDER CODE 2	Metal modesty panel with laminate insert
---------------------	--

ORDER CODE 1	Metal modesty panel only (no laminate insert)
---------------------	---

- 16 ga steel
- 9"H panel attaches to worksurface
- Available with or without laminate insert

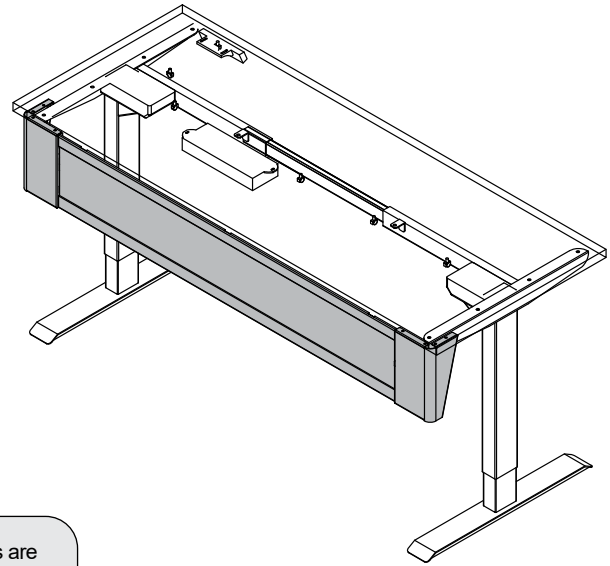
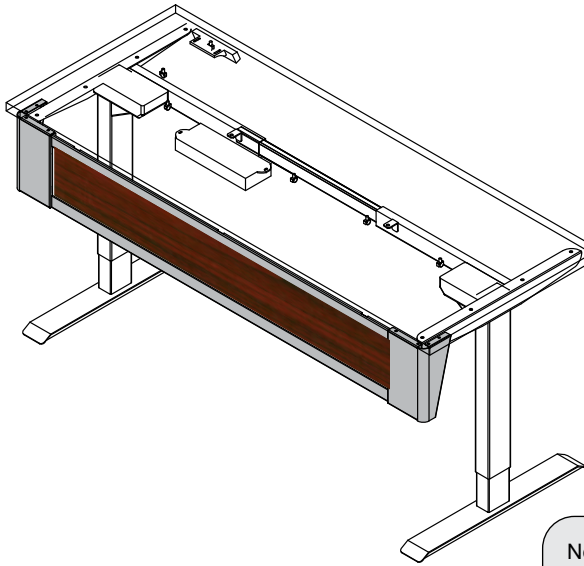

Note: Electric legs are available in black only.

Modesty panel laminate insert color

ORDER CODE 00	None
ORDER CODE BK	Black
ORDER CODE BL	Bronze Legacy
ORDER CODE CH	Wild Cherry
ORDER CODE CK	Castle Oak
ORDER CODE CS	Cafe Sienna
ORDER CODE CW	Colombian Walnut
ORDER CODE DZ	Desert Zephyr
ORDER CODE EM	Empire Mahogany
ORDER CODE FM	Fusion Maple
ORDER CODE GT	Graphite Talc

ORDER CODE GY	Gray
ORDER CODE IG	Island
ORDER CODE MZ	Misted Zephyr
ORDER CODE NP	Nepal Teak
ORDER CODE NR	Navajo Red
ORDER CODE PM	Pewter Mesh
ORDER CODE RB	Royal Blue
ORDER CODE SM	Steel Mesh
ORDER CODE WC	Williamsburg Cherry
ORDER CODE WD	Chalk White Dry Erase
ORDER CODE WF	White Fiesta

Packaging options

ORDER CODE S	Single pack
ORDER CODE B	Bulk pack (8 or more)

Note: Flex Active Tables are available in bulk pack quantities of 8 or more. Although there is cost-savings of consolidating into bulk packaging, access to a truck-height loading dock, forklift, or other means of unloading the pallets from the truck is necessary.

Flex Active electric (24"D)

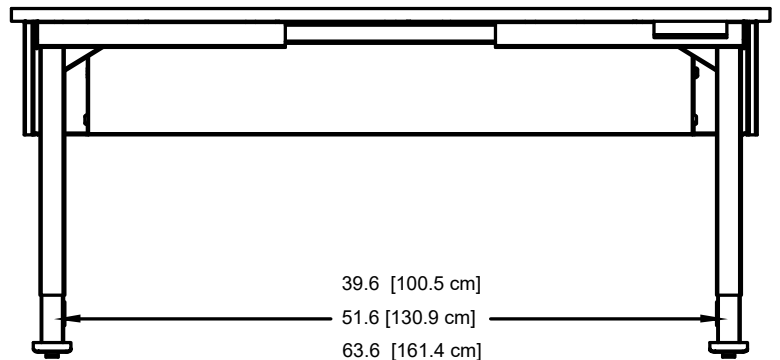
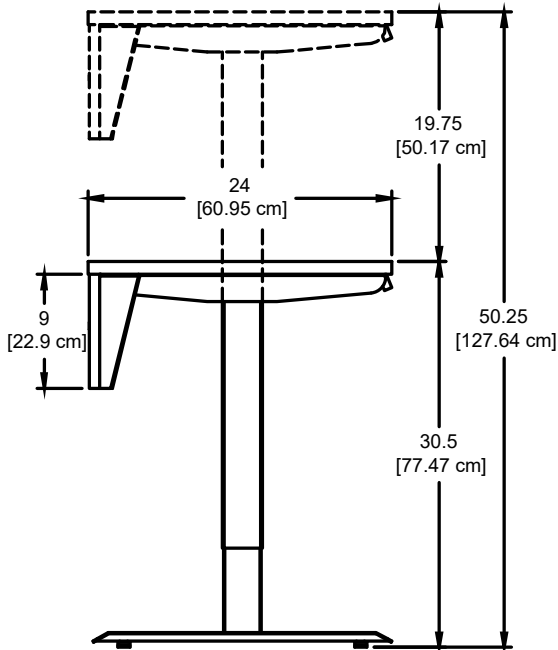
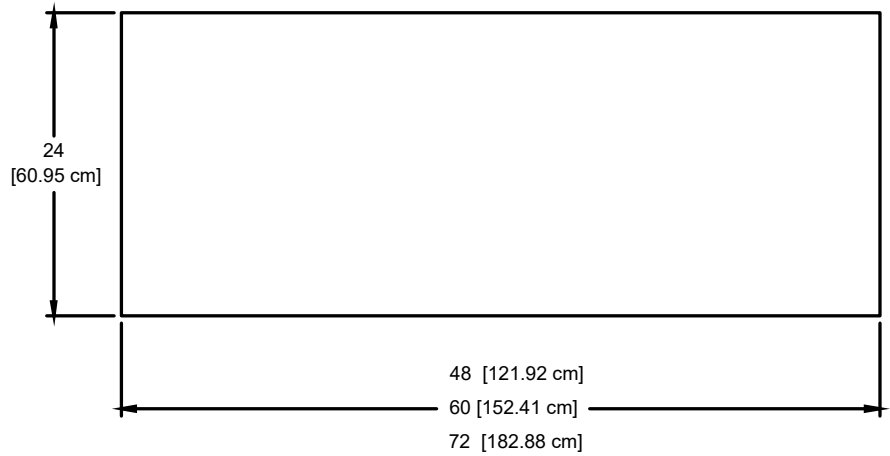
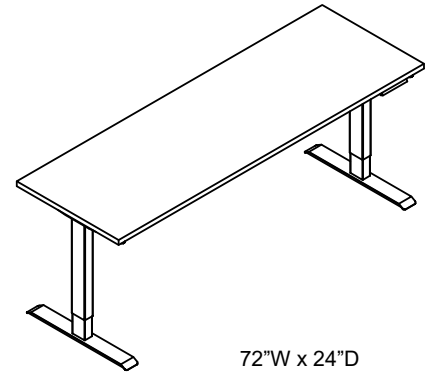
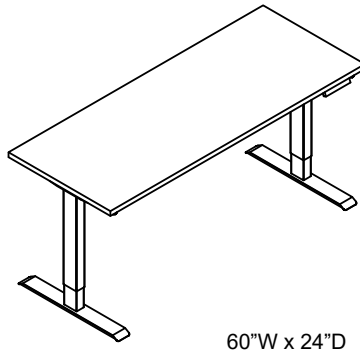
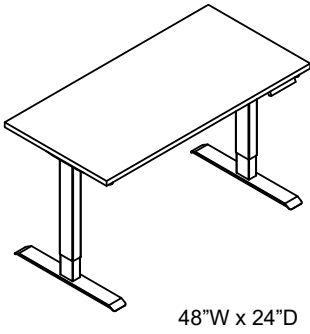

Shown with optional modesty panel and glides.

Note: When determining leg spacing with optional CPU sling 38925 subtract the width of each CPU sling (up to 2) from the leg spacing dimension shown.

Flex Active electric (30"D)

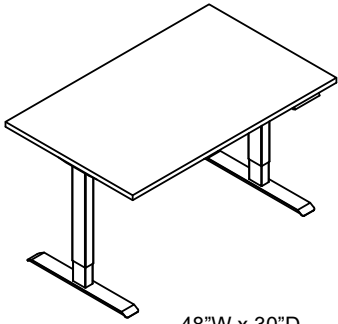

48"W x 30"D

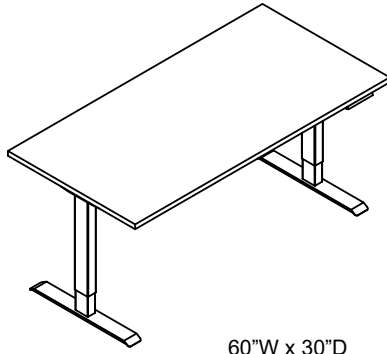

60"W x 30"D

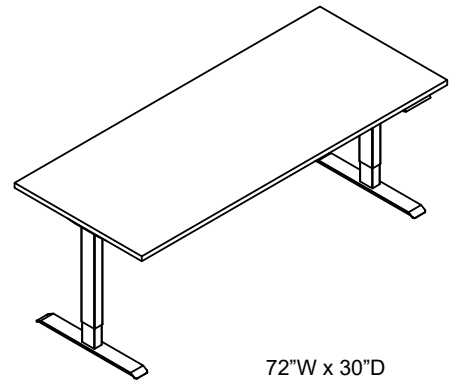

72"W x 30"D

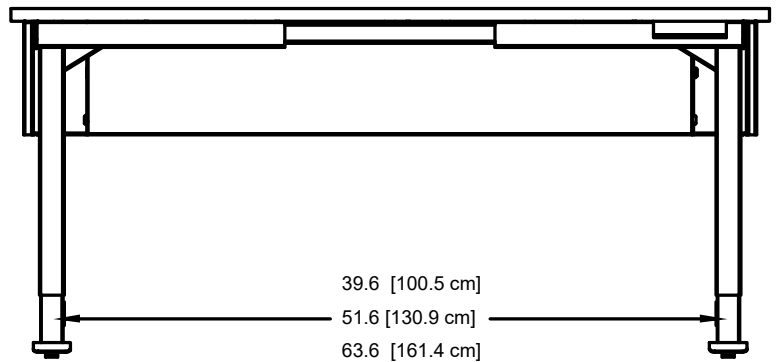
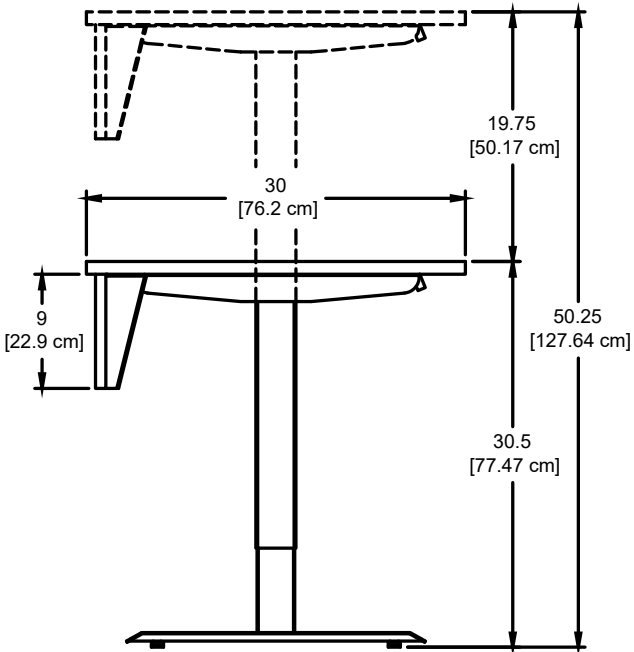
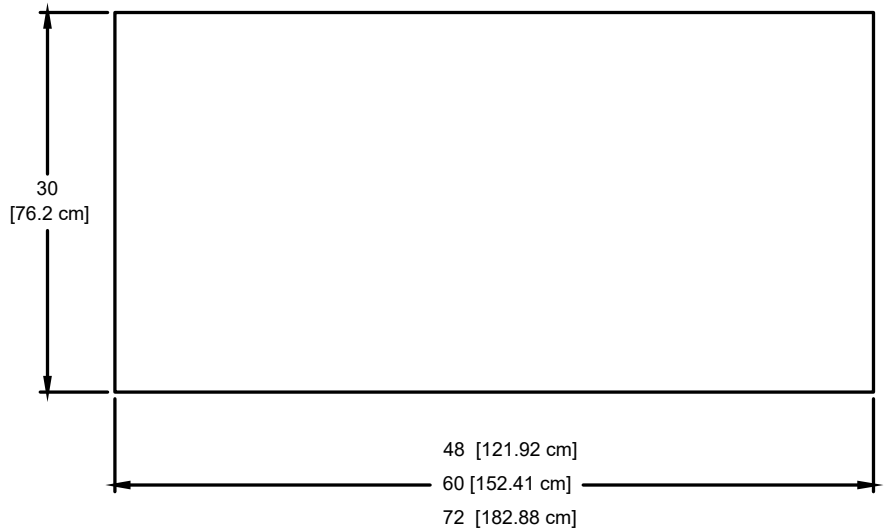

Shown with optional modesty panel and glides.

Accessories

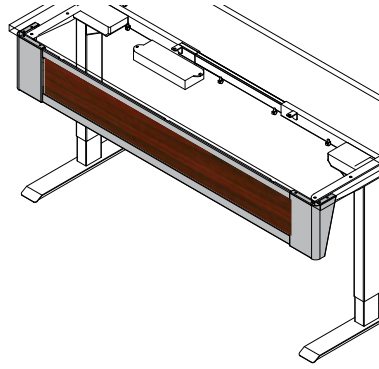
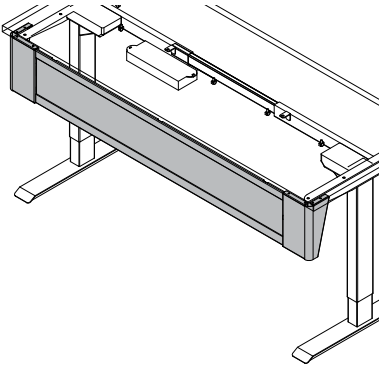

Modesty Panel

- 37234** - (for 48"W table)
- 37235** - (for 60"W table)
- 37236** - (for 72"W table)

- 16 ga steel
- 9"H panel attaches to worksurface
- Available with or without laminate insert
- Fasteners included



Flat Panel Monitor Arm

- 95512** - for monitors weighing 2-13 lb
- 95522** - for monitors weighing 7.5-25 lb
- 95509** - for monitors weighing 12-31 lb

- Six mounting options (clamp, thru-desk, wall, grommet hole, side bolt, reverse wall)
- Compatible with all VESA® monitors - includes 75mm and 100mm VESA® adapters
- Cable management concealed in arm



Dual Flat Panel Monitor Arm - 95533

- Weight range: 3.5-13 lb per monitor
- Six mounting options (clamp, thru-desk, wall, grommet hole, side bolt, reverse wall)
- Compatible with all VESA® monitors - includes 75mm and 100mm VESA® adapters
- Cable management concealed in arm



Heavy-Duty Monitor Arm

- 95539** - without USB & multimedia ports
- 95540** - with USB & multimedia ports

- Adjustable gas spring counterbalance
- Weight range: 2.2-33lb
- Fits most 17-35" monitors
- Quick-release 75mm, 100mm, VESA® mounting plate
- Clamp or grommet mounting
- Optional (2) USB 3.0 ports and (2) 3.5mm jacks for mic / headphones
- Cable management channel



7-Outlet Power Strip - 99024

- Electrical Rating: AC 125V, 15 Amps
- 1000 Joules surge capacity
- 12' cord length
- LED switch
- UL Listed
- Shipping weight: 1.9 lb [.86 kg]

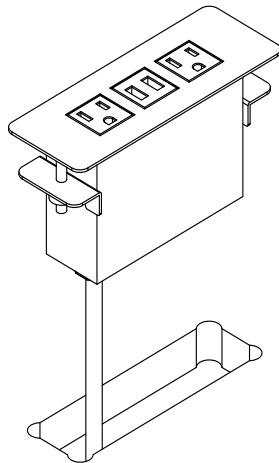

Power Module - 99060

- (2) AC power receptacles
- (2) USB charge ports
- Aluminum housing and flange
- Thumbscrew clamps
- Requires worksurface cutout
- ETL-certified
- Available in black, silver, or white
- Customer-installed

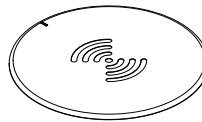

EM Wireless Charging Pad - 99057

- Uses electromagnetic technology to charge Qi V1.2 compliant IC devices ("Qi" enabled)
- LED to confirm pairing / charging
- Security tab prevents theft
- Requires 3" round cutout to be made by customer
- UL-certified

Note: The unit requires a 7" diameter of clearance to work with Qi-enabled phones placed in any orientation. The 3" dia cutout should be located on the worksurface at least 3.5" from any edge.

Warranty

We will make it right for you!

Thanks for choosing Spectrum! Spectrum is committed to provide complete customer satisfaction. Each of our products is manufactured from the best materials available and each product is stringently monitored throughout the production process through our P.A.C.E. program (Product Assurance to meet Customer Expectations).

We expressly warrant that Spectrum products will be of good quality and workmanship and free from defect for the period set out in the warranty from the date of delivery.

For a listing of all product specific warranty terms please visit our website at:

<https://www.spectrumfurniture.com/en/resources/purchasing-terms-warranty>

1-800-235-1262

Toll-free HELPLINE

spectrum@spectrumfurniture.com



Pending



Spectrum Industries is Certified ISO 9001:2015