

# Assembly Instructions

## ⚠ Important ⚠

Before you begin, read and comply with all safety and operating instructions, and ensure all parts and correct quantities are included.

Any parts damaged during shipment must be reported within 5 days of receipt. To report information regarding missing parts or damage, to purchase parts or accessories, or if you have any questions, please contact us.

[www.spectrumfurniture.com](http://www.spectrumfurniture.com)  
800-235-1262, 715-723-6750

Thank you for purchasing Spectrum products!

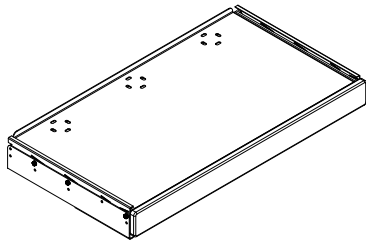

(1) Keyboard Tray Assembly

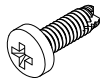

(4) 0100167  
8-32 x 1/2" PH  
Thread-cutting screw

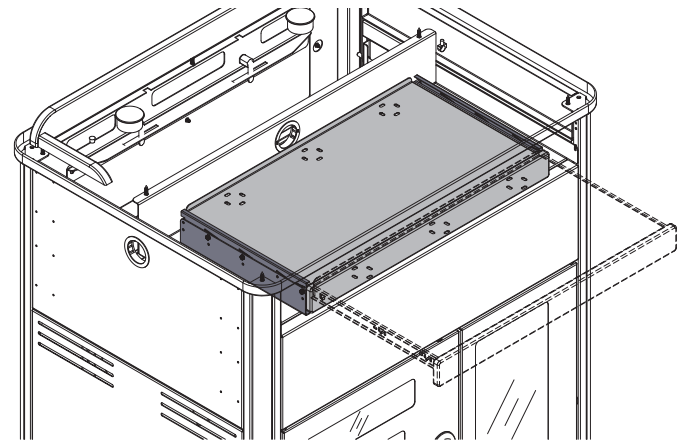

## Keyboard Tray for Media Manager Elite Lectern 95537

Note: Not compatible with  
55113-2RU Rack Rail Kit



### 1. Align mounting holes

1. Set the keyboard tray onto the mid-panel and align the 4 mounting holes. **Figure 1.**

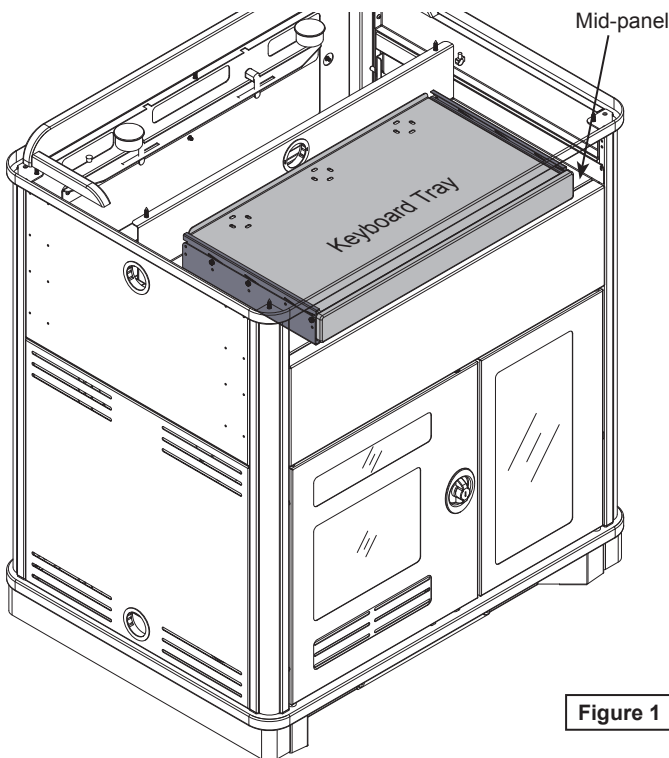

Figure 1

### 2. Remove audience-side panel

1. Push in the top of the narrow flip-up panel to access the locks. (Do not pry open this panel). **Figure 2.1.**
2. Unlock both locks while supporting the audience-side panel. **Figure 2.2.**
3. Lift out the panel.

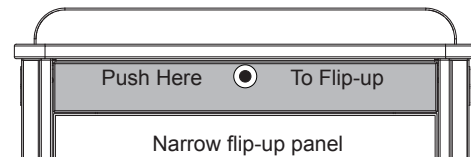

Figure 2.1

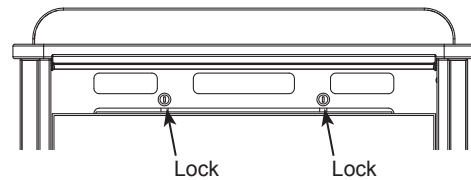

Figure 2.2

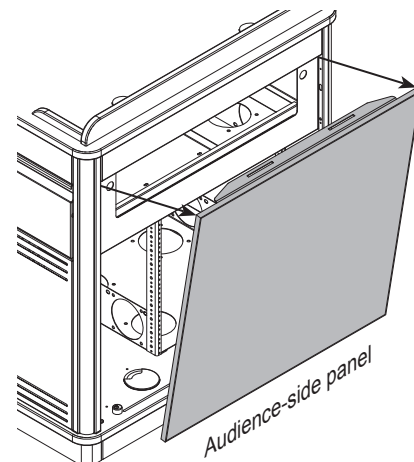

Figure 2.3

### 3. Install screws

1. From inside the lectern, install the (4) 8-32 x 1/2" PH Thread-cutting screws through the mid-panel mounting holes to secure the tray, and tighten securely. **Figure 3.**

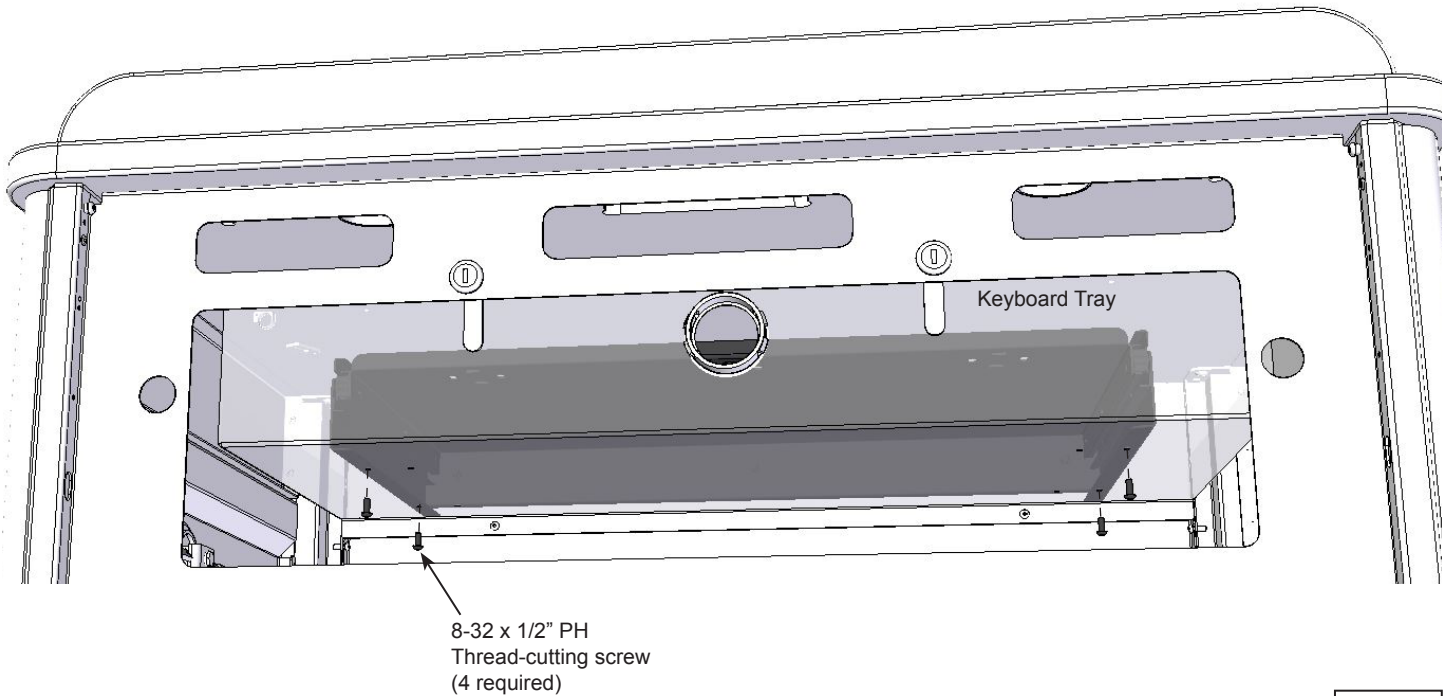

Figure 3

### Flipping keyboard tray / drawer - Optional

Note: Can be used as a keyboard tray, or flipped and used as a drawer.

1. To flip, pull the tray out fully and locate the black plastic lever on each slide. **Figure 4.**
2. Release the levers on the both slides while pulling the tray out.
3. Flip the tray over, re-align the slides, and push back in.

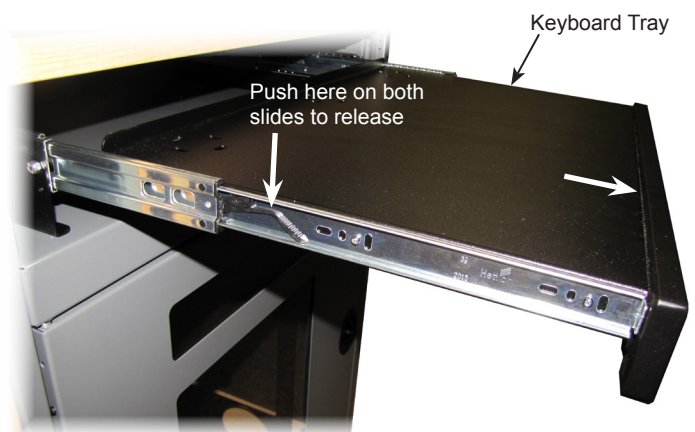

Figure 4