

Technical Specifications

55489

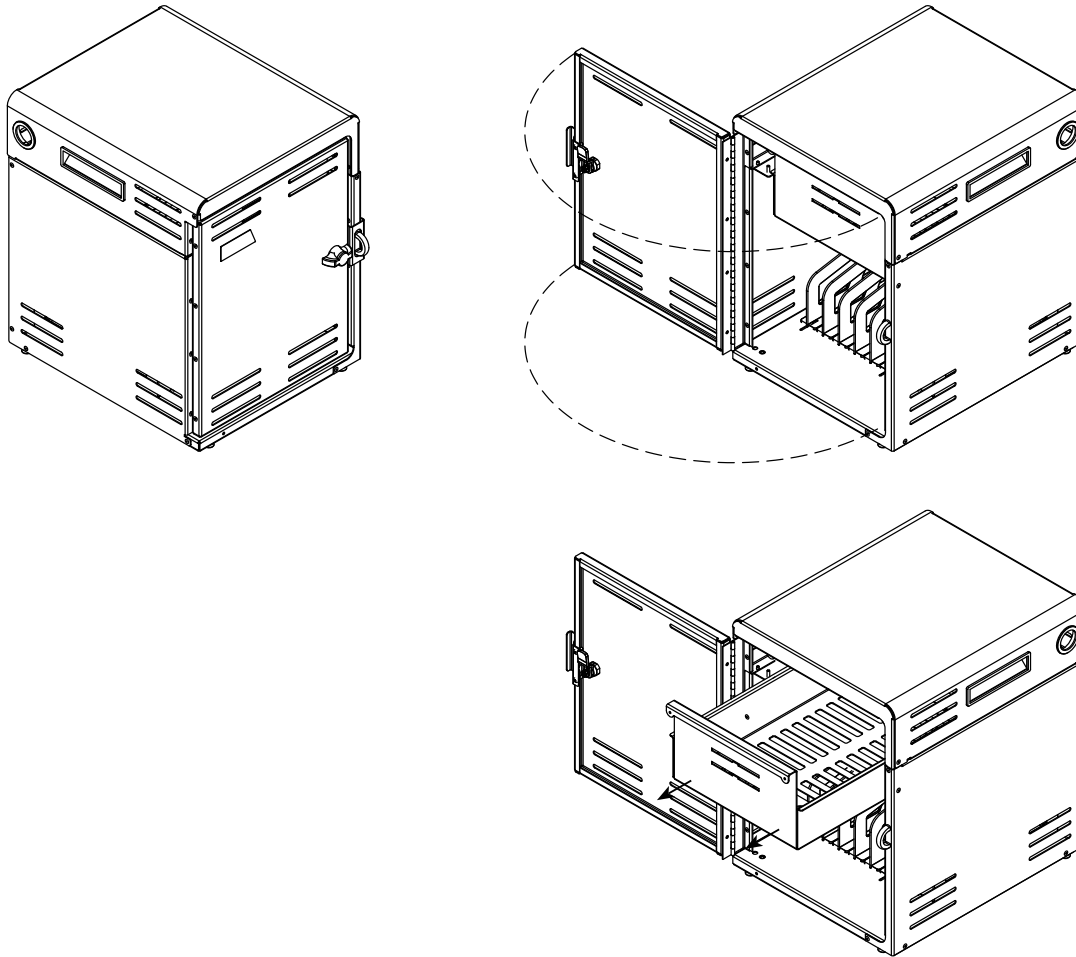

Use the Connect10 Locker to store and charge up to 10 devices (tablets, Chromebooks™, or notebooks). Flexible dividers protect the computer devices from damage and overhead wire management in a pullout tray aids wiring integration, and allows the charging plugs to hang in front of each device. The Connect10 Locker's small footprint covers less counter space, and is made with powder-coated steel for security and durability. A single-bolt lock, integrated padlock hasp on the door, Kensington® lock capabilities, and surface-mounting all provide additional levels of security.



Features and Benefits

- Stores and charges up to 10 tablets, Chromebooks™, or notebooks
- 1.25"W [3.17 cm] x 14.39"D [36.55 cm] x 10.122"H [25.7 cm] universal storage bay (numbered 1-10)
- Durable ABS plastic dividers (dividers are removable to provide storage space for thicker devices)
- Single point winged keyed lock and heavy gauge steel door provide security
- Integrated padlock hasp in the hinged door provides an additional level of security and the ability to use your padlock* of choice (not included)
- Unit can be anchored to a floor, permanent worksurface or wall for additional stability and security. (2) #14 x 1-3/4" PHSM screws are provided for anchoring to a wood worksurface or wall stud. (Fasteners for concrete applications not provided)
- Locker can be hung from a wall using optional wall hanging kit
- Multiple lockers can be stacked and secured to each other using optional stacking kit
- Power drawer provides easy-access to electrical power while keeping line voltage, wiring, and cords away from students
- Superior, all-metal overhead cord management system keeps charge cords organized above each storage bay
- Cart is available prewired with USB-C PD chargers
- Ventilated door and side panels keep devices cool, preventing overheating, and extending device life
- Side grommets placed for effective cord management
- Optional 10-outlet, surge-suppressed power strip
- Locker ships fully-assembled for quick, simple integration and deployment
- Durable powder coated steel chassis provides a long lasting finish
- Warranted to be free of all defects in materials and workmanship for 10 years, electrical system 2 years
- Designed and assembled in Chippewa Falls, WI, USA

- 55489-DOO** - Connect10 Locker
- 55489-DOU** - Connect10 Locker w/ 10-outlet power strip
- 55489-USBC** - Connect10 Locker w/ USB-C PD charging (prewired)

- Color Options**
- Warm Gray (cabinet)
 - Black (door)

*Padlock not included
revised 12/21/22

Construction

- Metal components consist of 16-gauge steel
- 16-gauge side panels, shelf, drawer, and door
- All metal components are finished with a scratch-resistant powder coat epoxy
- Each Connect10 Locker is factory-assembled

Specifications

Capacity	10 devices	
Storage bays (nominal)	1.25"W [3.17 cm] x 14.39"D [36.55 cm] x 10.122"H [25.7 cm]	
Power Tray	10.715"W [27.22 cm] x 13.5"D [34.3 cm] x 6.193"H [15.73 cm]	
Electrical (power strip)	<ul style="list-style-type: none"> • Includes one 10-outlet power strip • Outlet type: NEMA 5-15R • 11.1" [28.2 cm] x 5.7 [14.5 cm] x 1.29" [3.28 cm] • 120V AC / 15A • 10-outlets (widely spaced) • Integrated safety covers • 2880-joule surge protection rating • Grounded status LED • Protected status LED • ON / OFF switch 	<ul style="list-style-type: none"> • Resettable 15-amp circuit breaker prevents dangerous overloads • Filters out EMI / RFI line noise that can cause equipment damage or data loss • 6' [183cm] nominal 3-wire power cord, 14 ga • Right angle NEMA 5-15P plug • Unit weight: 1.71 lb [.78 kg] • Shipping weight: 2.12 lb [.96 kg] • Certifications: cUL • Compliance: RoHS
Certifications / Compliance	Meets or exceeds applicable ANSI-BIFMA test standards	
Unit weights (nominal)	40 lb [18.2 kg] - 55489 (no power) 42 lb [19.1 kg] - 55489	
Shipping weights (nominal)	42 lb [19.1 kg] - 55489 (no power) 44 lb [20 kg] - 55489	

Specifications subject to change without notice

USB-C PD Charger
(USB-C PD prewired locker only)



Specifications:

- Model: HA712
- Input: 100-240V ~ 50/60Hz 1.5A
- Output (USB-C PD): 5V~3A
9V~3A 12V~3A 15V~3A
20V~3.25A
- Dimensions: 1.97" x 1.97" x 1.10"
(50mm x 50mm x 28mm)
- Net Weight: 3.42 oz [97 g]

10-outlet power strip

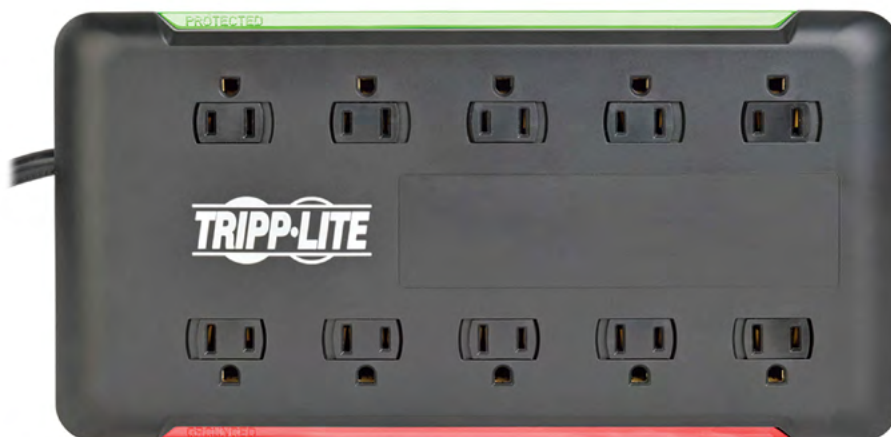

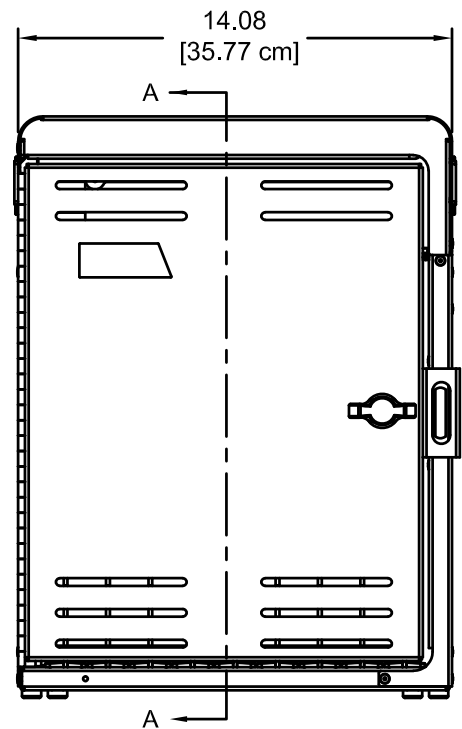
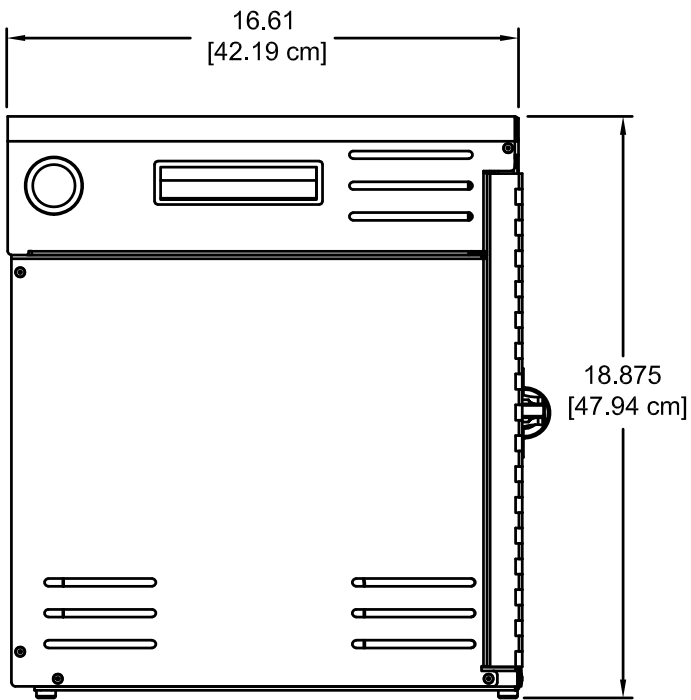
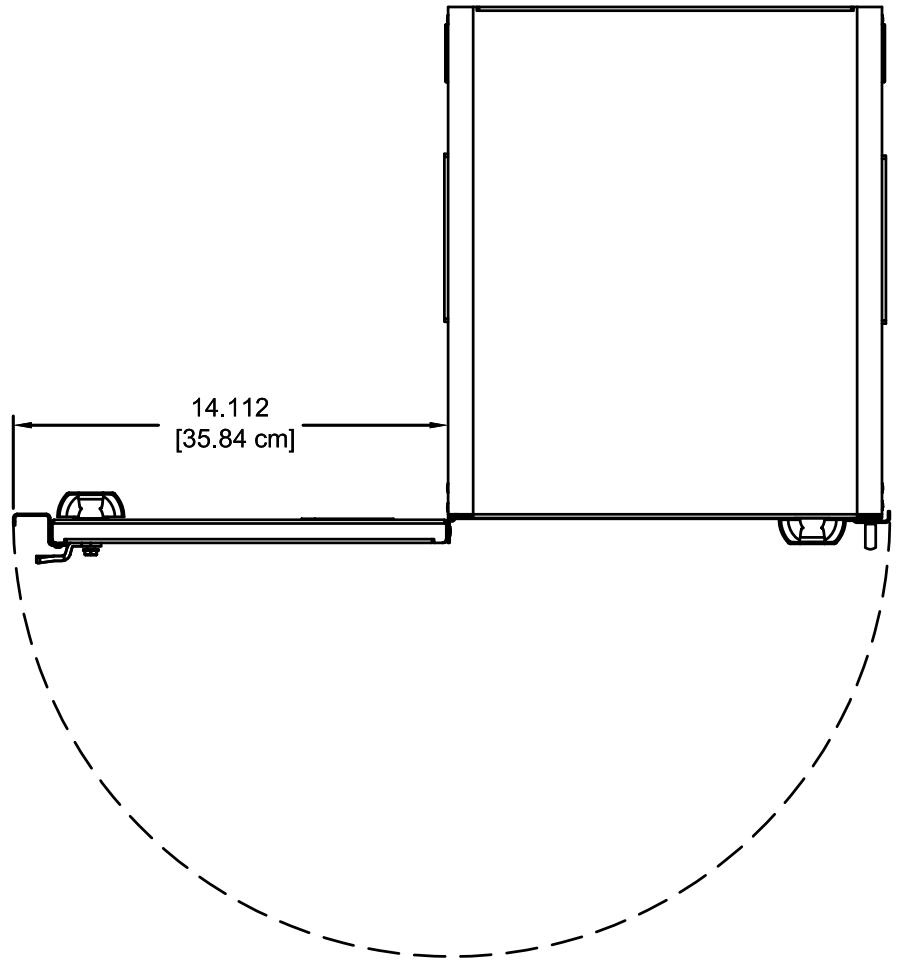
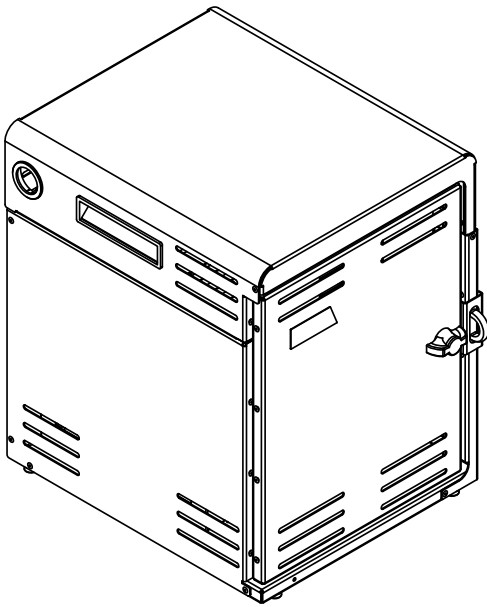

Section View A-A

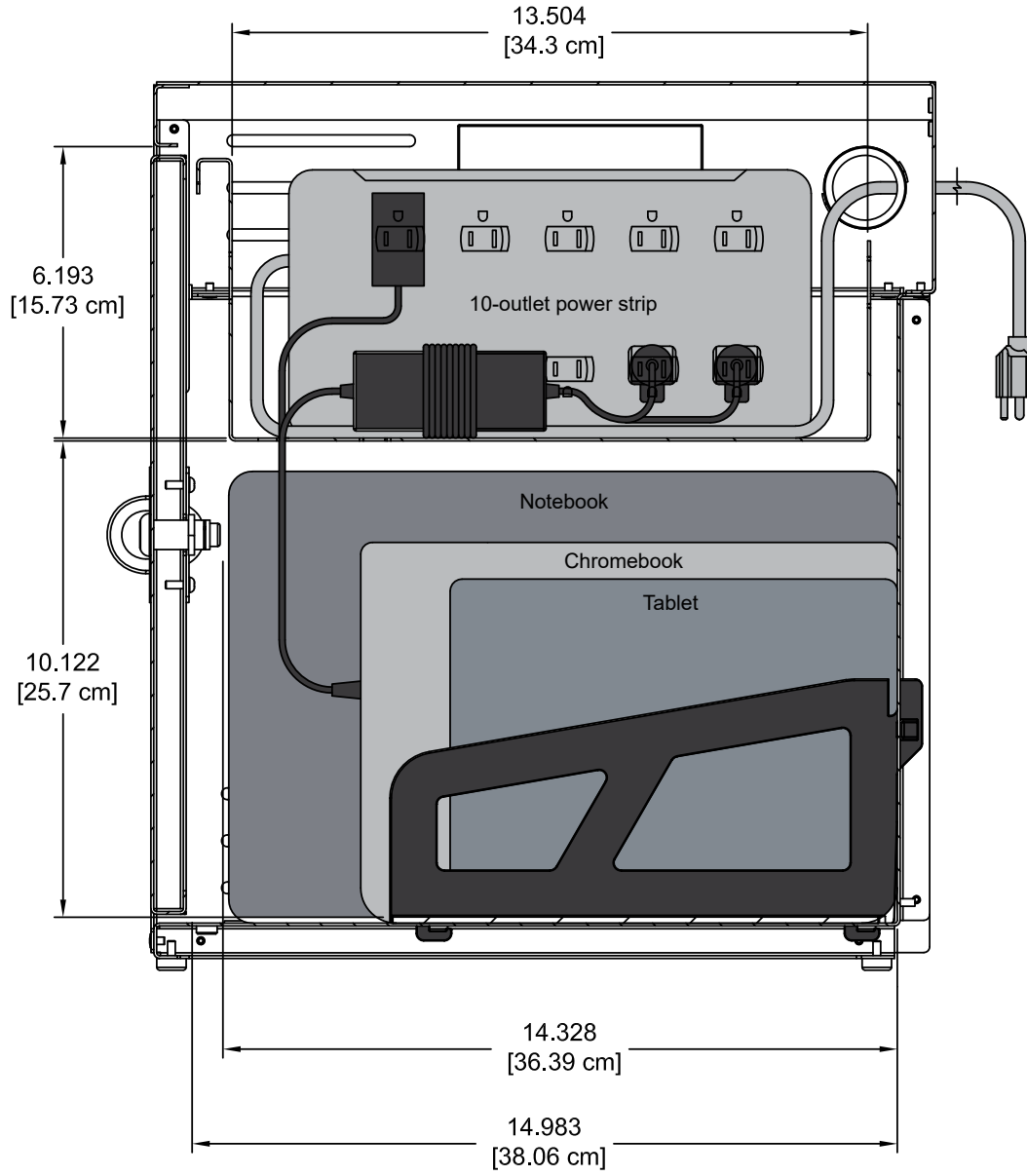

Device-side view with tablets

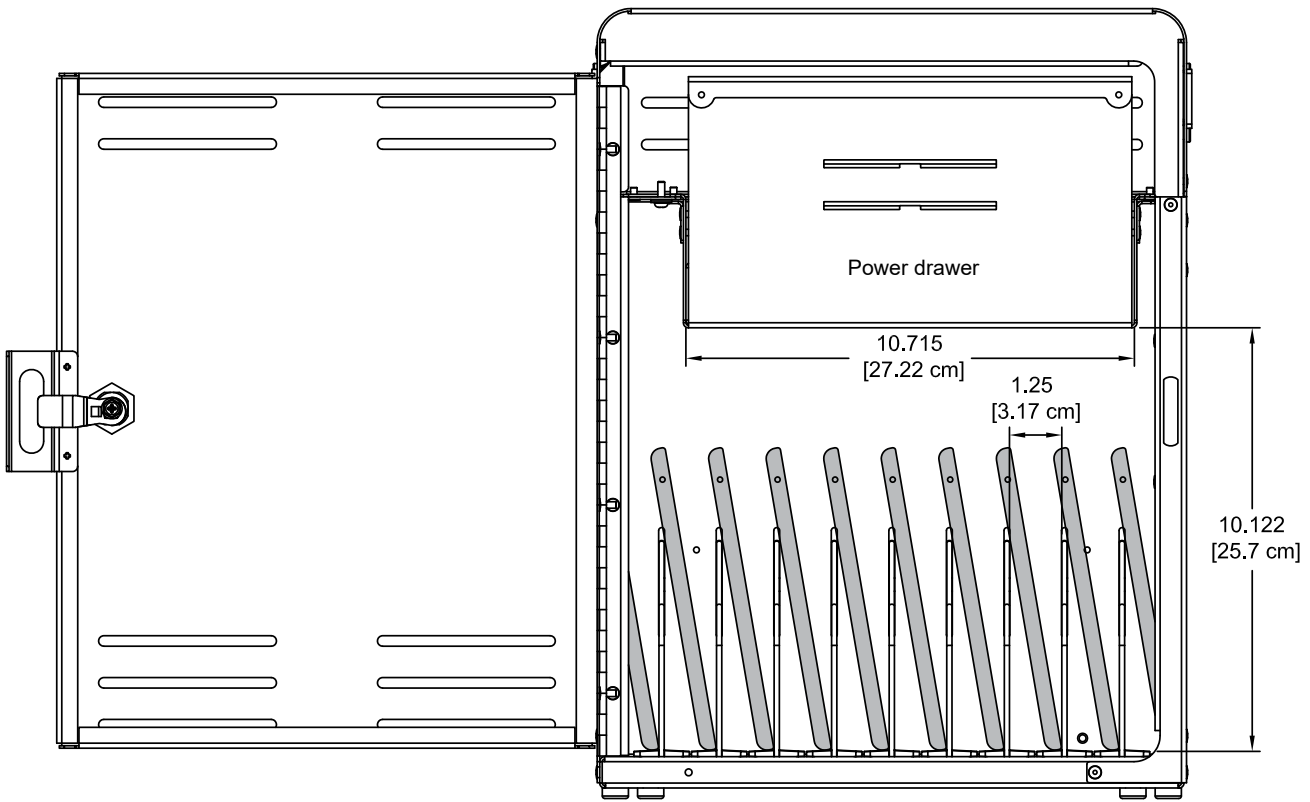

Bottom view of anchor holes

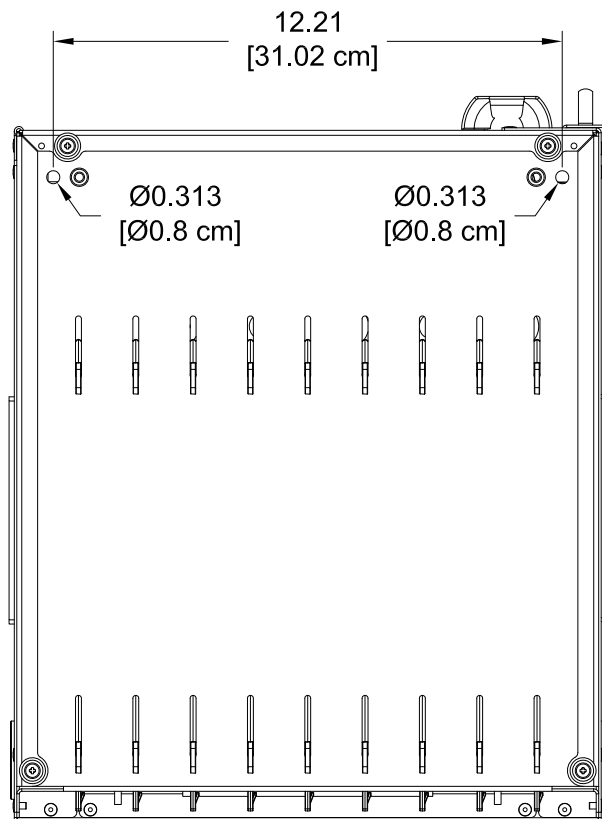

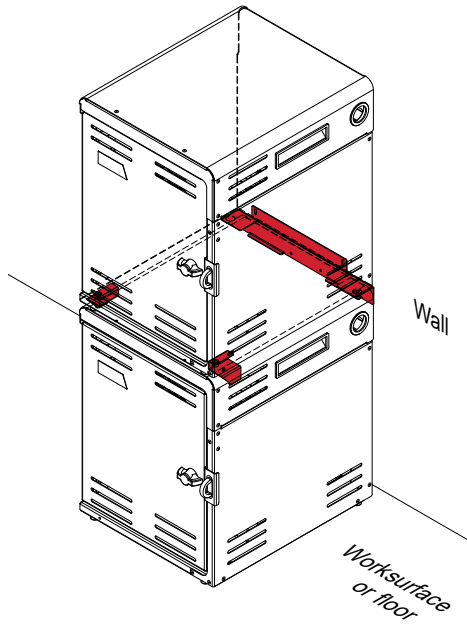

Stacking Kit - 55491

- Secures to worksurface/floor and wall (Not designed to hang locker from wall)
- One 55491 kit will stack one locker onto another that sits on a worksurface or floor (one kit required for each additional level)
- Max recommended stack height: 2 units (stack of 2 or more must be secured to floor or wall)
- 2 lb [.9 kg]

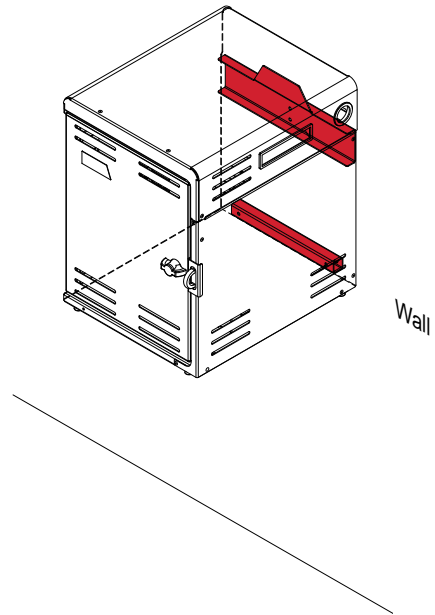

Wall Hanging Kit - 55490

- One 55490 kit will attach one locker to a wall
- One 55490 kit required per locker
- Fasteners included for concrete wall applications
- To fully comply with ADA guidelines, it's recommended the locker be hung above base cabinets or other permanent structure that extends to the floor.
- 175 lb [79.5 kg] capacity
- 3 lb [1.4 kg]

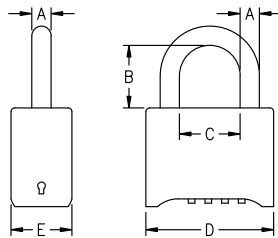

A	.3125" [7.9 mm]
B	1" [25.4 mm]
C	.983" [25 mm]
D	2.07" [52.5 mm]
E	.987" [25.1 mm]

Re-programmable 4-digit Combination Lock - 95536

- Set your own 4-digit personalized combination (up to 10,000 options)
- 5/16" hardened steel shackle for cut-resistance
- Black powdercoated die-cast body for durability
- Change key included
- Unit weight: .55 lb [.25 kg]

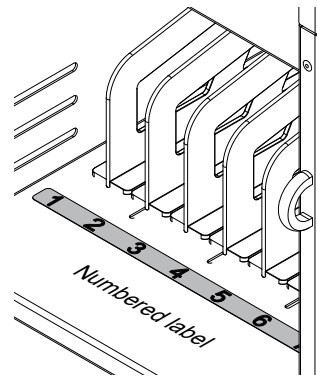

Bay Label Kit - 55492

- Numbered 1-10 label
- Black numbers on transparent adhesive backer

See [spectrumfurniture.com](https://www.spectrumfurniture.com) for the latest accessories and detailed warranty information.

Warranty

We will make it right for you!

Thanks for choosing Spectrum! Spectrum is committed to provide complete customer satisfaction. Each of our products is manufactured from the best materials available and each product is stringently monitored throughout the production process through our P.A.C.E. program (Product Assurance to meet Customer Expectations).

We expressly warrant that Spectrum products will be of good quality and workmanship and free from defect for the period set out in the warranty from the date of delivery.

For a listing of all product specific warranty terms please visit our website at:

<https://www.spectrumfurniture.com/en/resources/purchasing-terms-warranty>

1-800-235-1262

Toll-free HELPLINE

spectrum@spectrumfurniture.com